

100 Simple T



Axiale Abluftventilatoren

- Max. Förderleistung: 95
- Schalldruckpegel LpA @ 3 m: 34
- Motortyp: AC

	Maßeinheit	100 Simple T
Luftkanalgröße	mm	100
Speed	-	1
Versorgungsspannung min	V	220
Versorgungsspannung max	V	240
Frequenz der Netzversorgung	Hz	50
Leistung	W	14
Stromaufnahme	A	0.09
Max. Förderleistung	m ³ /h	95
Schalldruckpegel LpA @ 3 m	dB(A)	34
Gewicht	kg	0.58
Ambientlufttemperatur, min	°C	1
Ambientlufttemperatur, max	°C	40
Schutzart	-	IP34

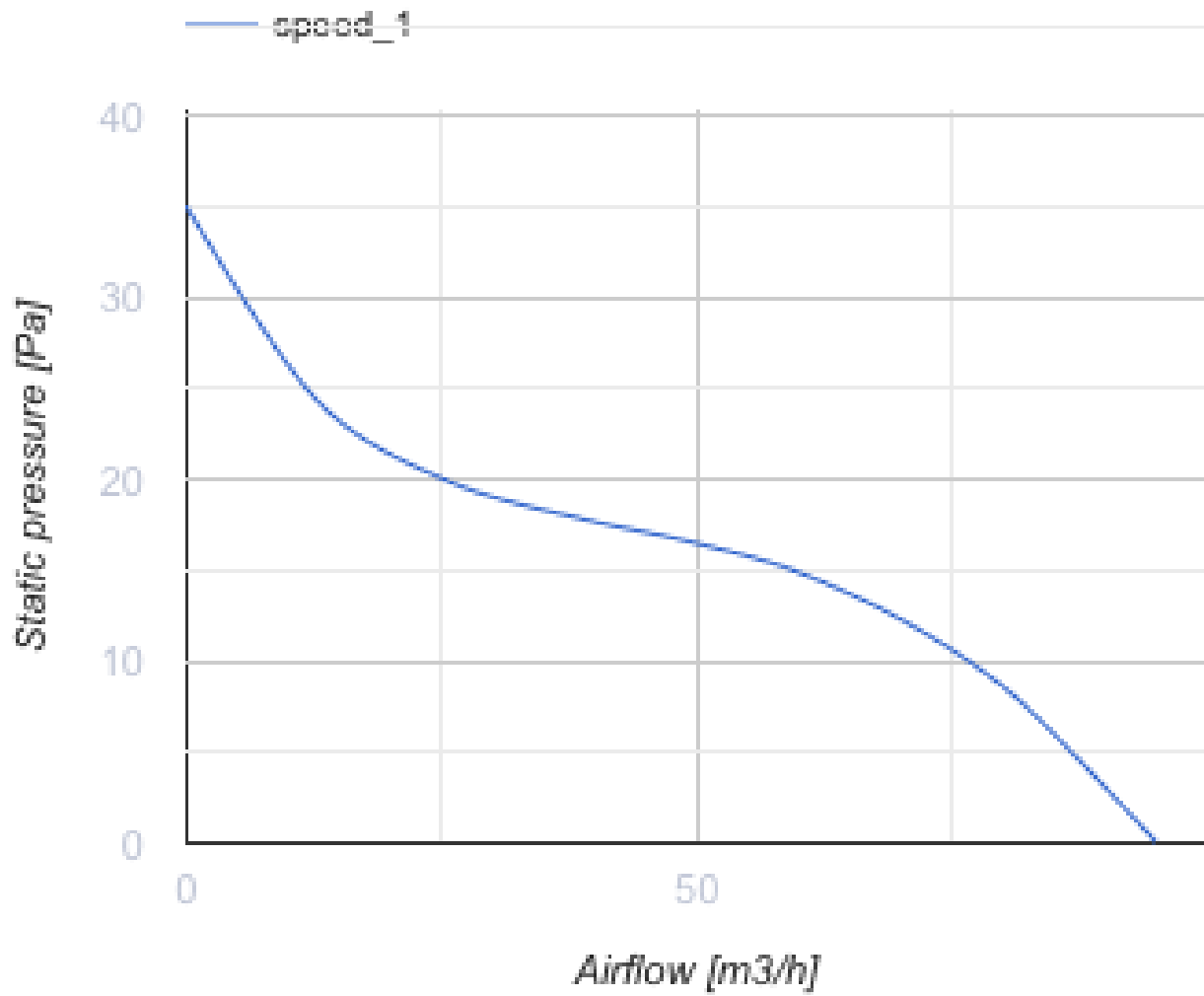

Abmessungen

Ø D	B	L	L1
100	150	97	15

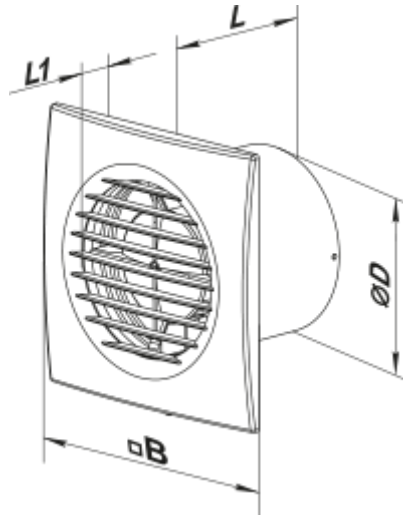

Zubehör

Flansche

Produktname	Foto	Beschreibung
FO_100		Das Fensterflansch ist einsetzbar für alle VENTS Lüfter, außer VKO, VKO1, iFan, Quiet, MAO, CF

Ecodesign



Warenzeichen	Vents					
Modell	100 Simple T					
Specific energy consumption (SEC) (kWh/(m ² /a))	Kalt		Durchschnittlich		Warm	
	-32.3	B	-14.4	E	-4.1	F
Typ des Lüftungsgeräts	Unidirectional					
Antriebsart	Single speed					
Art des Wärmerückgewinnungssystems	Keines					
Max. Luftvolumenstrom (m ³ /h)	95					
Elektrische Eingangsleistung (W)	14					
Bezugs-Luftvolumenstrom (m ³ /s)	0.018					
Specific power input (SPI) (W/(m ³ /h))	0.147					
Control typology	Clock control					
Maximum external leakage rates (%)	2.7					
Angabe des Typs	RVU UVU					
Sound power level (dB(A))	54					
The annual electricity consumption (AEC) (kWh/a)	Kalt		Durchschnittlich		Warm	
	175		175		175	
The annual heating saved (AHS) (kWh/a)	Kalt		Durchschnittlich		Warm	
	3667		1874		848	