

# TT 125 S



## Halbradiale Rohrventilatoren

- Max. Förderleistung: 440
- Schalldruckpegel LpA @ 3 m: 42
- Motortyp: AC
- Laufradtyp: Mixed
- Gehäusematerial: Plastic
- In jeder Position

	Maßeinheit	TT 125 S	
Luftkanalgröße	mm	125	
Speed	-	2	
Versorgungsspannung min	V	230	
Versorgungsspannung max	V	230	
Frequenz der Netzversorgung	Hz	50/60	
Leistung	W	47	60
Stromaufnahme	A	0.21	0.27
Max. Förderleistung	m <sup>3</sup> /h	295	440
Schalldruckpegel LpA @ 3 m	dB(A)	31	42
Gewicht	kg	3.14	
Fördermitteltemperatur max	°C	60	
Fördermitteltemperatur min	°C	-25	
Schutzart	-	IPX4	
Motorschutzart	-	IPX4	

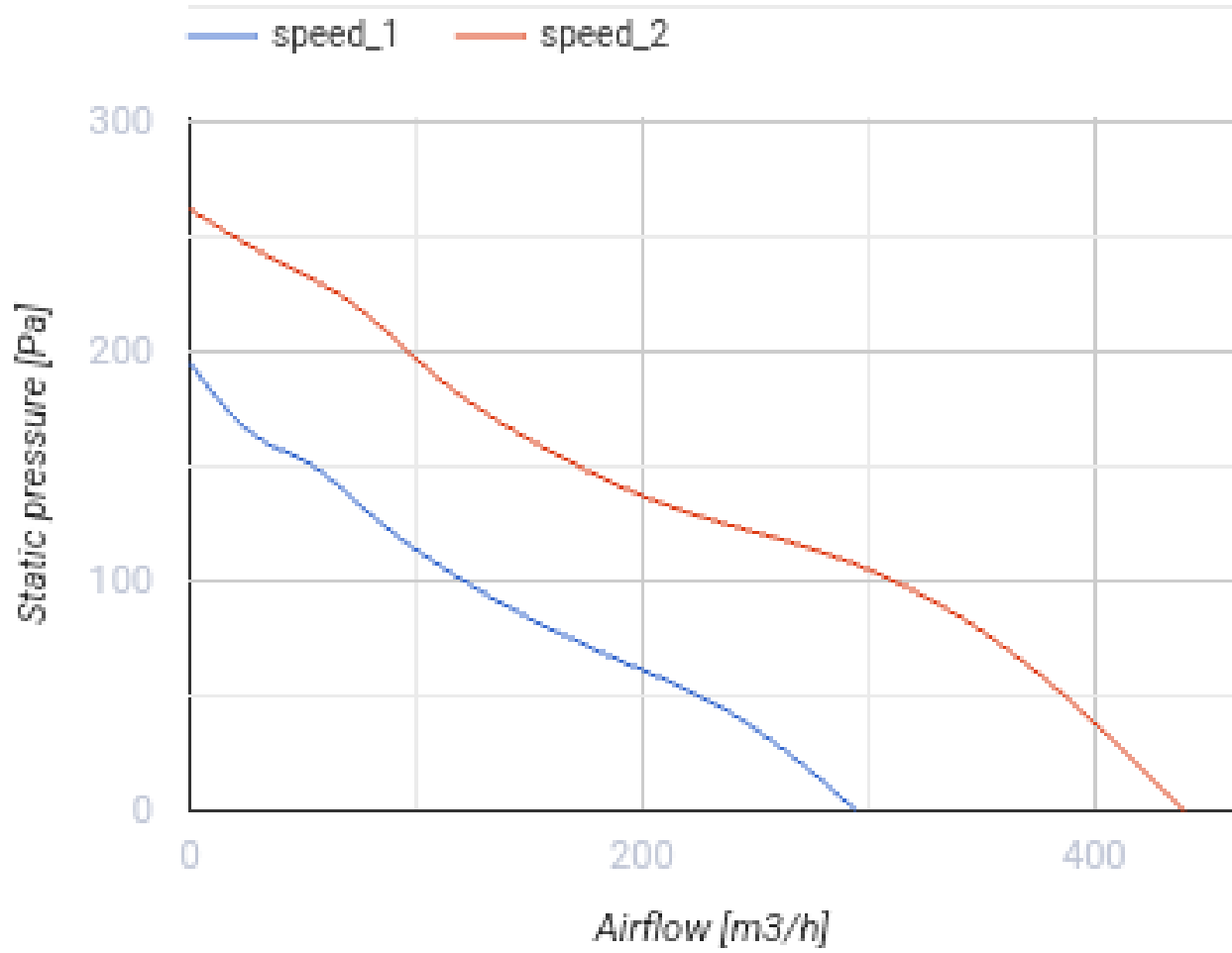

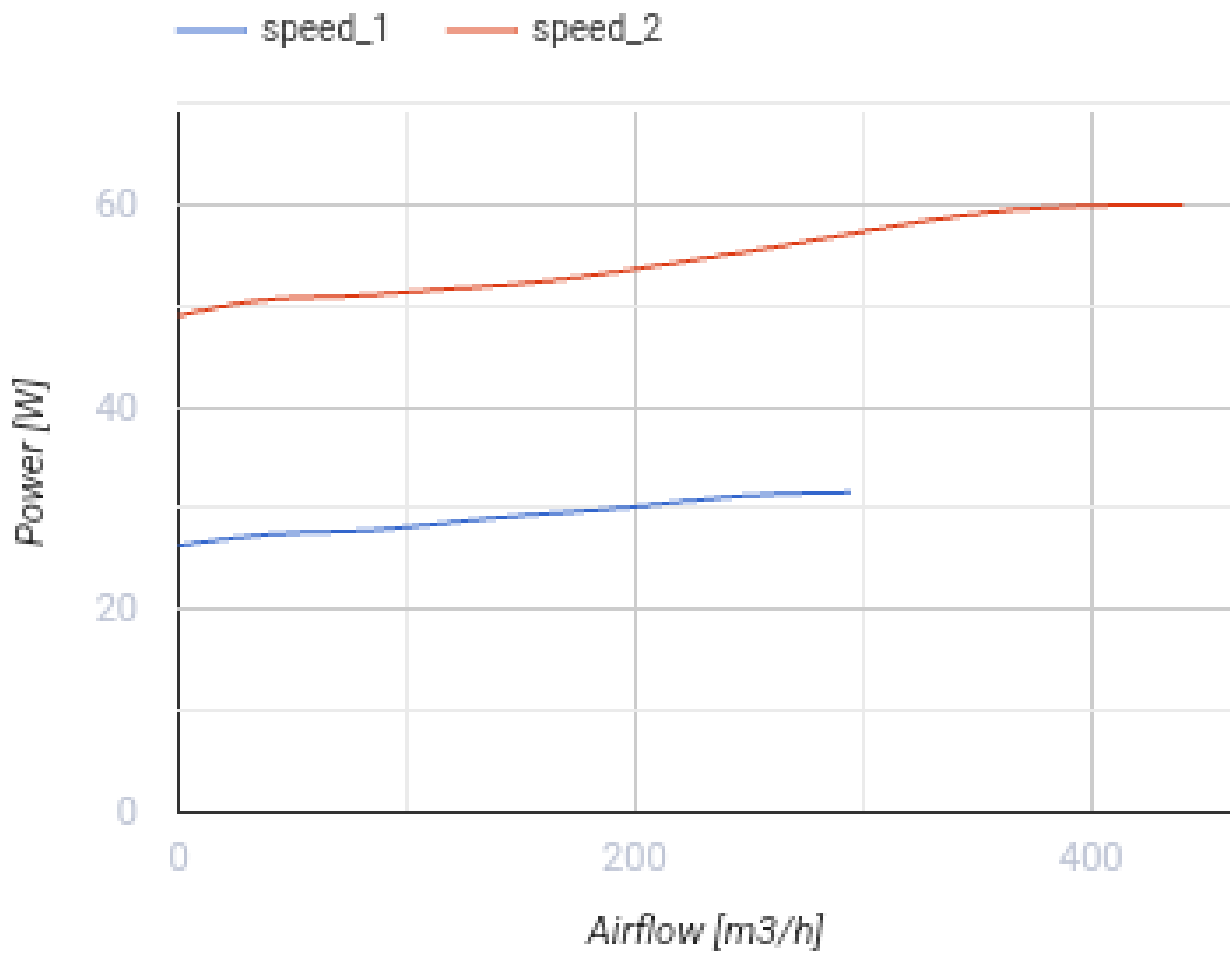

### Abmessungen

ØD	B	H	L
123	167	190	246

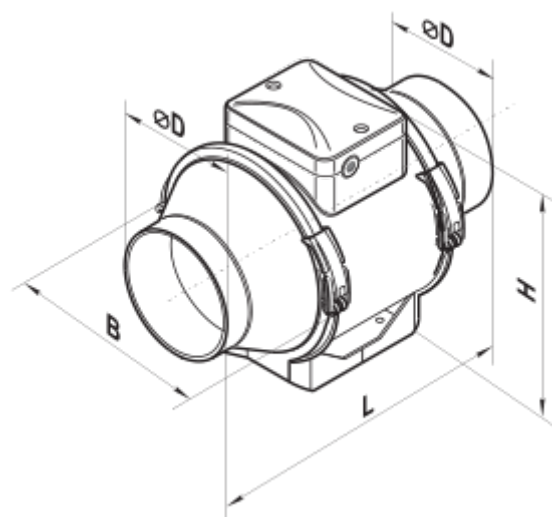

## Ecodesign

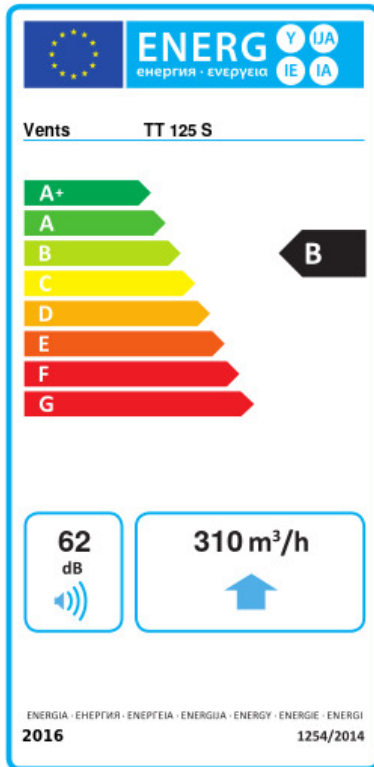

Warenzeichen	Vents					
Modell	TT 125 S					
Specific energy consumption (SEC) (kWh/(m <sup>2</sup> /a))	Kalt		Durchschnittlich		Warm	
	-53.6	A+	-26.5	B	-11	E
Typ des Lüftungsgeräts	Unidirectional					
Antriebsart	Drehzahlregelung					
Art des Wärmerückgewinnungssystems	Keines					
Max. Luftvolumenstrom (m <sup>3</sup> /h)	310					
Elektrische Eingangsleistung (W)	56					
Bezugs-Luftvolumenstrom (m <sup>3</sup> /s)	0.071					
Reference pressure difference (Pa)	50					
Specific power input (SPI) (W/(m <sup>3</sup> /h))	0.134					
Control typology	Local demand control					
Maximum external leakage rates (%)	2.7					
Angabe des Typs	RVU UVU					
Sound power level (dB(A))	62					
The annual electricity consumption (AEC) (kWh/a)	Kalt		Durchschnittlich		Warm	
	71		71		71	
The annual heating saved (AHS) (kWh/a)	Kalt		Durchschnittlich		Warm	
	5536		2830		1280	