

# TT PRO 100 V



## Diagonal-Rohrventilatoren

- Max. Förderleistung: 245
- Schalldruckpegel LpA @ 3 m: 32
- Motortyp: AC
- Steuerung: Built-in speed controller
- Laufradtyp: Mixed
- Gehäusematerial: Kunststoff
- In jeder Position

	Maßeinheit	TT PRO 100 V	
Luftkanalgröße	mm	100	
Speed	-	2	
Versorgungsspannung min	V	230	
Versorgungsspannung max	V	230	
Frequenz der Netzversorgung	Hz	50/60	
Leistung	W	23	25
Stromaufnahme	A	0.10	0.11
Max. Förderleistung	m <sup>3</sup> /h	180	245
Schalldruckpegel LpA @ 3 m	dB(A)	27	32
Gewicht	kg	1.75	
Fördermitteltemperatur max	°C	60	
Schutzart	-	IPX4	
Motorschutzart	-	IPX4	

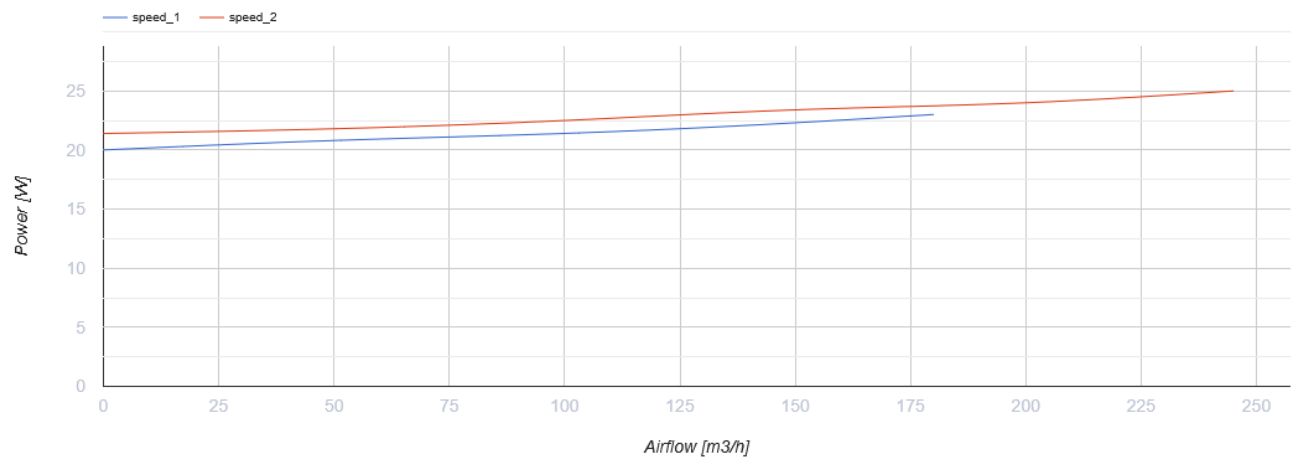
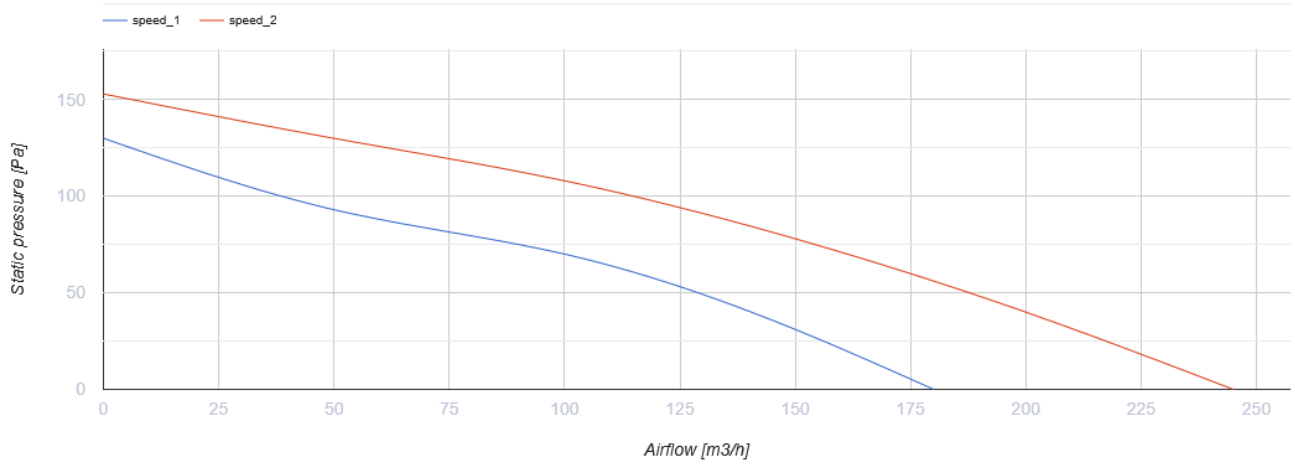

## Abmessungen

ØD	B	H	L
97	195.8	226	302.5

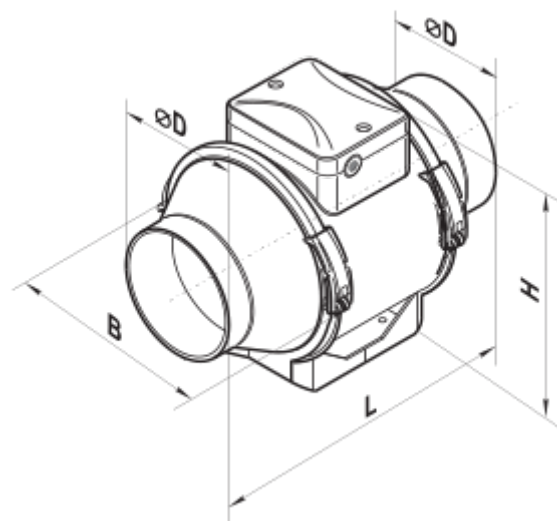

## Ecodesign

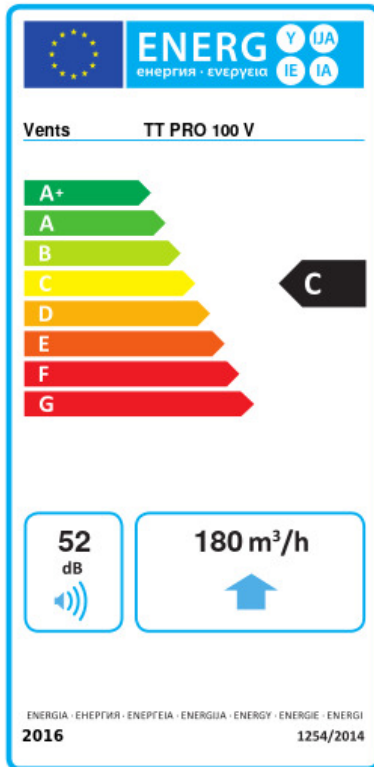

Warenzeichen	Vents					
Modell	TT PRO 100 V					
Specific energy consumption (SEC) (kWh/(m²/a))	Kalt		Durchschnittlich		Warm	
	52.9	A+	25.9	C	10.4	E
Typ des Lüftungsgeräts	Eine Richtung					
Antriebsart	Drehzahlregelung					
Art des Wärmerückgewinnungssystems	Keines					
Max. Luftvolumenstrom (m³/h)	180					
Elektrische Eingangsleistung (W)	25					
Bezugs-Luftvolumenstrom (m³/s)	0.035					
Reference pressure difference (Pa)	50					
Specific power input (SPI) (W/(m³/h))	0.183					
Control typology	Local demand control					
Maximum external leakage rates (%)	2.7					
Angabe des Typs	RVU UVU					
Sound power level (dB(A))	52					
The annual electricity consumption (AEC) (kWh/a)	Kalt		Durchschnittlich		Warm	
	97		97		97	
The annual heating saved (AHS) (kWh/a)	Kalt		Durchschnittlich		Warm	
	5536		2830		1280	