

Series
VUTR 400 EH EC/WH EC
VUTR 700 EH EC/WH EC
VUTR 900 EH EC/WH EC



Series
VUTR 1200 EH EC/WH EC
VUTR 1500 EH EC/WH EC



Series
VUTR 2000 EH EC/WH EC



Air handling units in heat- and sound-insulated casing with an electric or a water heater.
 Air flow up to **2250 m³/h**.
 Heat recovery efficiency up to **95 %**

■ **Description**

The air handling units VUTR EH EC with an electric heater and VUTR WH EC with a water heater are the fully-featured ventilation units that ensure air filtration, fresh air supply and stale air extract. Used in ventilation and air conditioning systems in commercial, office and other public or industrial premises that require an economical solution and a controlled ventilation system.

■ **Modifications**

VUTR EH EC models are equipped with an electric heater.

VUTR WH EC models are equipped with a water heater.

■ **Casing**

The casing consists of a frame and three-layer 20 mm (VUTR 1500 and 2000 – 25 mm) thick panels made of zinc aluminium internally filled with mineral wool for reliable heat- and sound-insulation.

■ **Filter**

The two integrated G4 filters ensure sufficient supply and extract air purification.

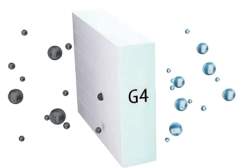

■ **Motor**

The air handling units are equipped with high-efficiency electronically commutated (EC) direct current motors with an external rotor and backward-curved blades.

■ **Rotary heat exchanger**

Units equipped with a rotary heat exchanger. As compared to plate heat exchangers, the rotary heat exchangers are distinguished with no condensate forming, ability to maintain comfortable air humidity and extremely low freezing danger.

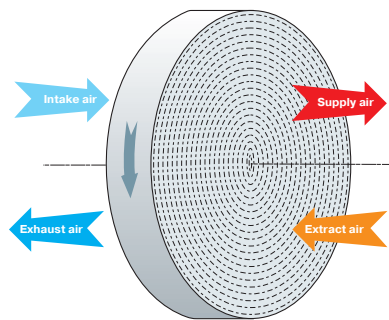

Rotary heat exchanger operation principle

■ **Heater**

The air handling units are equipped with electric heaters (VUTR EH EC models) or water heaters (VUTR WH EC models) to operate at low outside temperatures. The heaters are equipped with protecting devices to ensure safe and reliable operation of the unit.

■ **Control and automation**

The VUTR EH EC A17 and VUTR WH EC A17 units are equipped with a th-Tune control panel.



The VUTR EH EC A18 and VUTR WH EC A18 units are equipped with a pGD1 control panel.



Designation key

Series	Heat exchanger type	Rated air flow [m ³ /h]	Heater type	Pipe modification	Motor type	Control panel
VENTS VUT	R: rotary heat exchanger	400; 700; 900; 1200; 1500; 2000	E: electric W: water	H: horizontal	EC: synchronous motor with electronic control	A17: th-Tune A18: pGD1

Automation functions

- ▶ Speed selection: low, medium, high.
- ▶ Speed is individually adjusted from 0 to 100 % for the supply and the extract fans.
- ▶ Filter maintenance indication.
- ▶ Alarm indication.
- ▶ Timer-based operation.
- ▶ Week-scheduled operation.
- ▶ Supply air temperature control.
- ▶ CCU control.
- ▶ Air damper actuator controlling.

Overall dimensions

Model	Dimensions [mm]								
	øD	A	E	F	G	L	L1	H	J
VUTR 400 EH EC/400 WH EC	159	1050	225	167	333	648	200	670	440
VUTR 700 EH EC/700 WH EC	249	1210	243	180	340	745	260	700	580
VUTR 900 EH EC/900 WH EC	249	1210	243	180	340	745	260	700	580
VUTR 1200 EH EC/1200 WH EC	314	1335	373	220	438	745	-	880	460
VUTR 1500 EH EC/1500 WH EC	314	1430	427	275	460	855	-	1010	560
VUTR 2000 EH EC/2000 WH EC	-	1485	-	-	-	875	-	1010	630

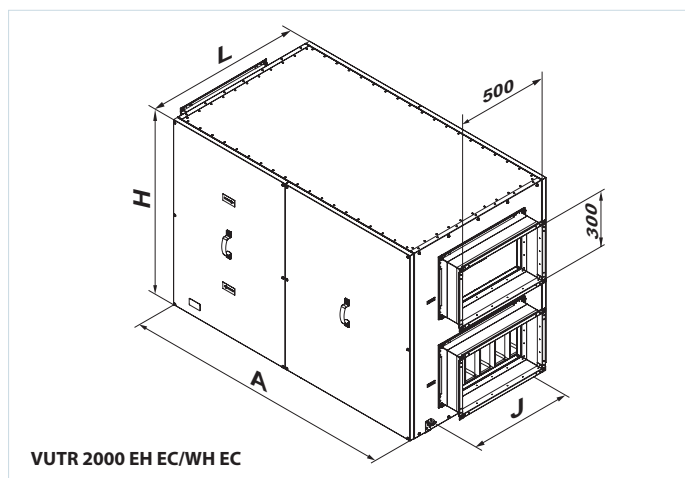
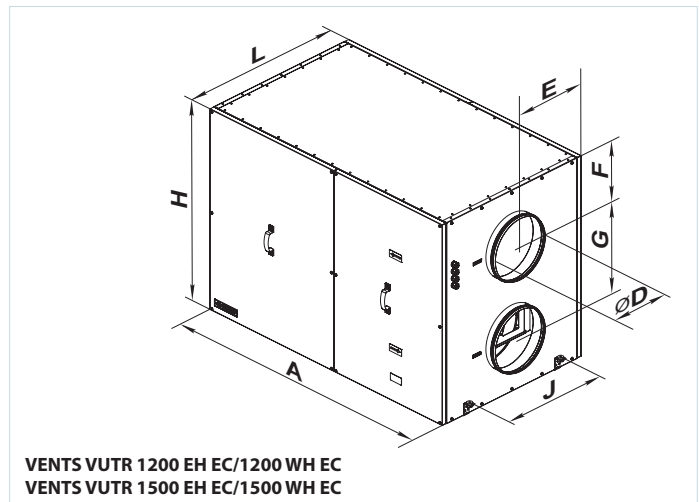
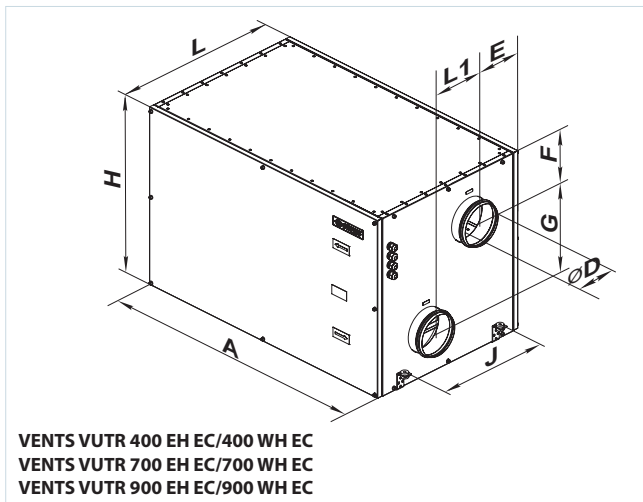

AIR HANDLING UNITS WITH HEAT RECOVERY

Technical data

	VUTR 400 EH EC	VUTR 400 WH EC	VUTR 700 EH EC	VUTR 700 WH EC	VUTR 900 EH EC	VUTR 900 WH EC
Voltage [V]	1~230		1~230		3~400	1~230
Maximum fan power [W]	200		210		270	
Electric heater power [kW]	2	-	3.3	-	4.5	-
Total unit power [W]	2290	290	3615	315	4940	440
Total unit current [A]	9.9	1.2	15.8	1.4	7.2	1.9
Maximum air flow [m ³ /h]	400		700		900	
Sound pressure level at 3 m distance [dBA]	45		52		58	
Transported air temperature [°C]	-25...+40					
Casing material	Aluzinc					
Insulation	20 mm mineral wool					
Extract filter	G4					
Supply filter	G4					
Connected air duct diameter [mm]	Ø160		Ø250		Ø250	
Mass [kg]	112		128		130	
Heat recovery efficiency [%]	80-95		76-95		72-95	
Heat exchanger type	rotary					
Heat exchanger material	aluminium					
SEC class	A					

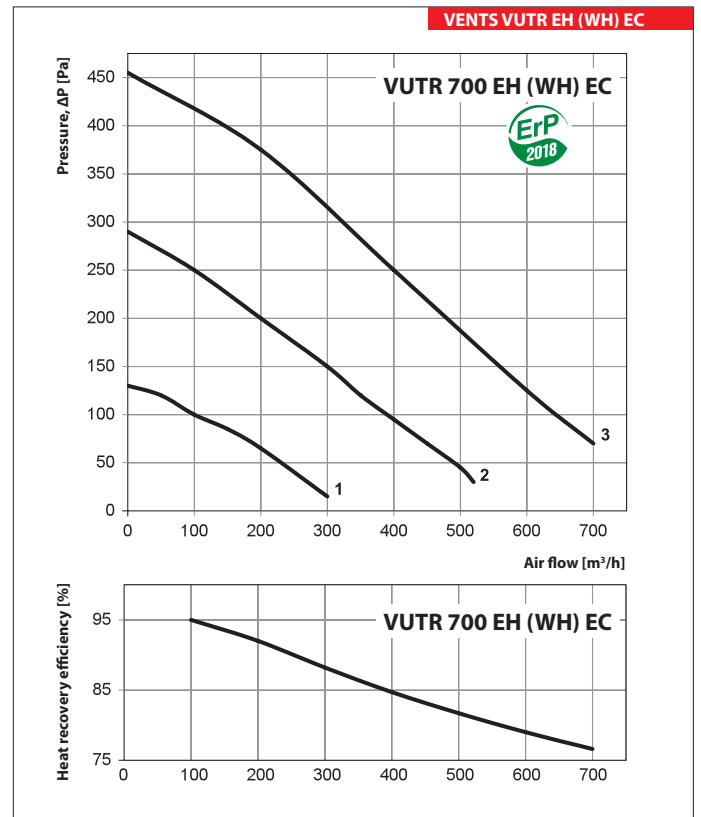
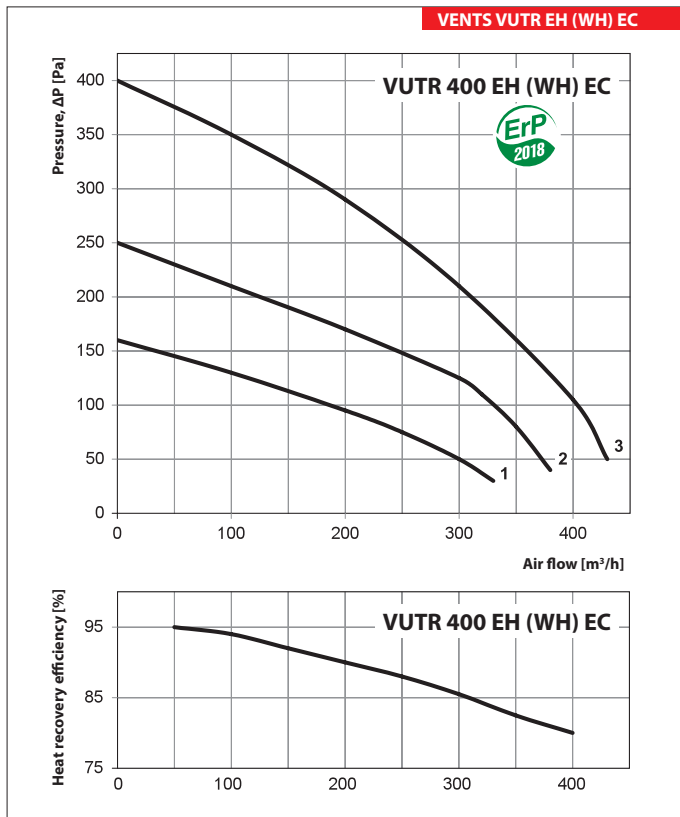

Technical data

	VUTR 1200 EH EC	VUTR 1200 WH EC	VUTR 1500 EH EC	VUTR 1500 WH EC	VUTR 2000 EH EC	VUTR 2000 WH EC
Voltage [V]	3~400	1~230	3~400	1~230	3~400	1~230
Maximum fan power [W]	416		444		896	
Electric heater power [kW]	6	-	9	-	12	-
Total unit power [W]	6570	570	9750	750	13070	1070
Total unit current [A]	9.5	2.5	14.1	3.2	22.4	5
Maximum air flow [m ³ /h]	1200		1500		2250	
Sound pressure level at 3 m distance [dBA]	60		62		64	
Transported air temperature [°C]	-25...+40					
Casing material	Aluzinc					
Insulation	20 mm mineral wool				25 mm mineral wool	
Extract filter	G4					
Supply filter	G4					
Connected air duct diameter [mm]	Ø315		Ø315		500x300	
Mass [kg]	165		175		198	
Heat recovery efficiency [%]	73-95		72-95		68-93	
Heat exchanger type	rotary					
Heat exchanger material	aluminium					

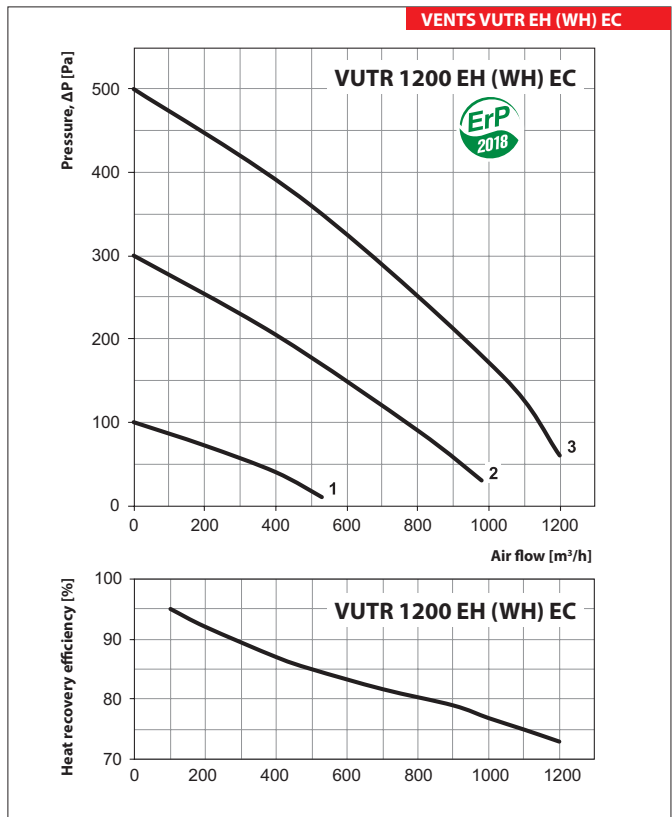
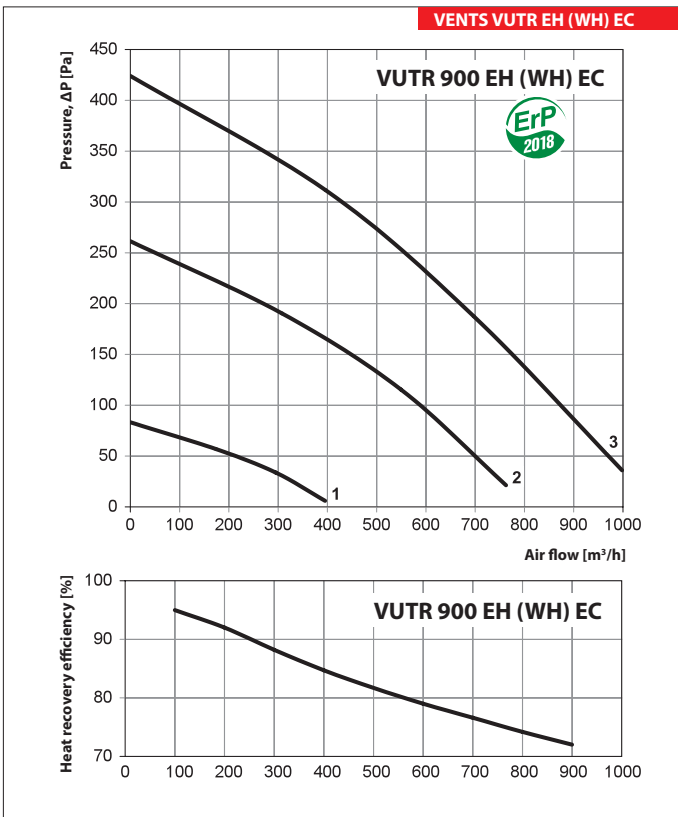

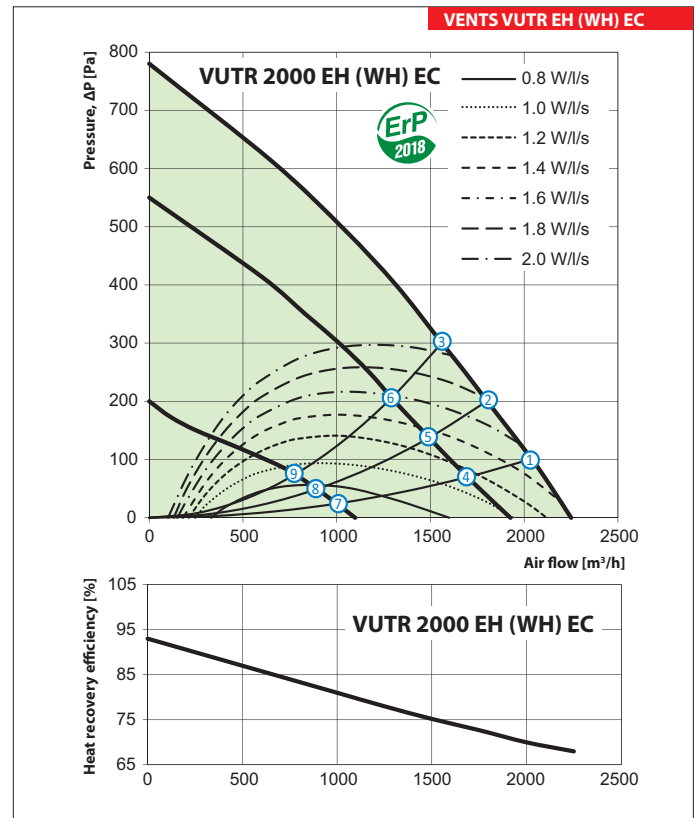
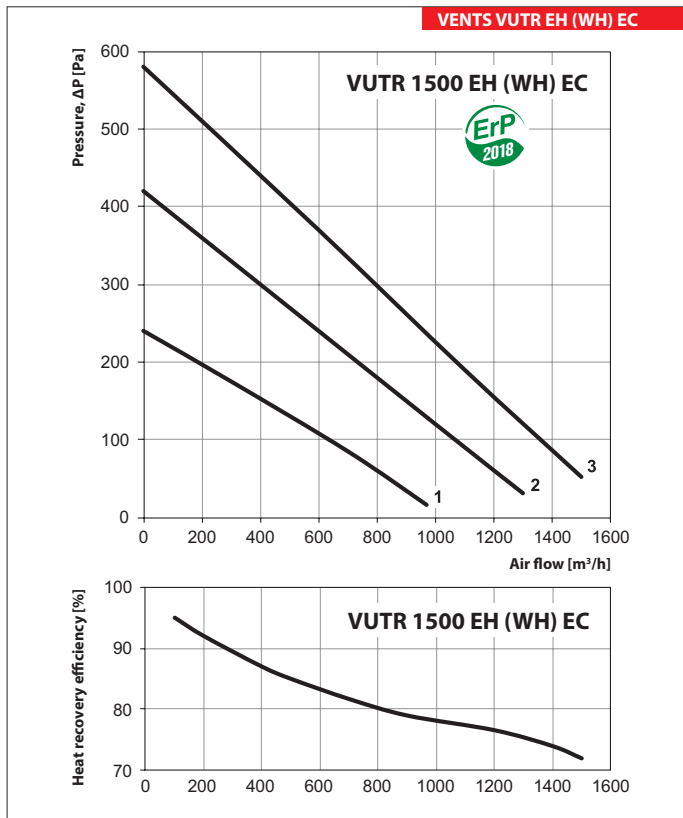

Water heater parameters calculation

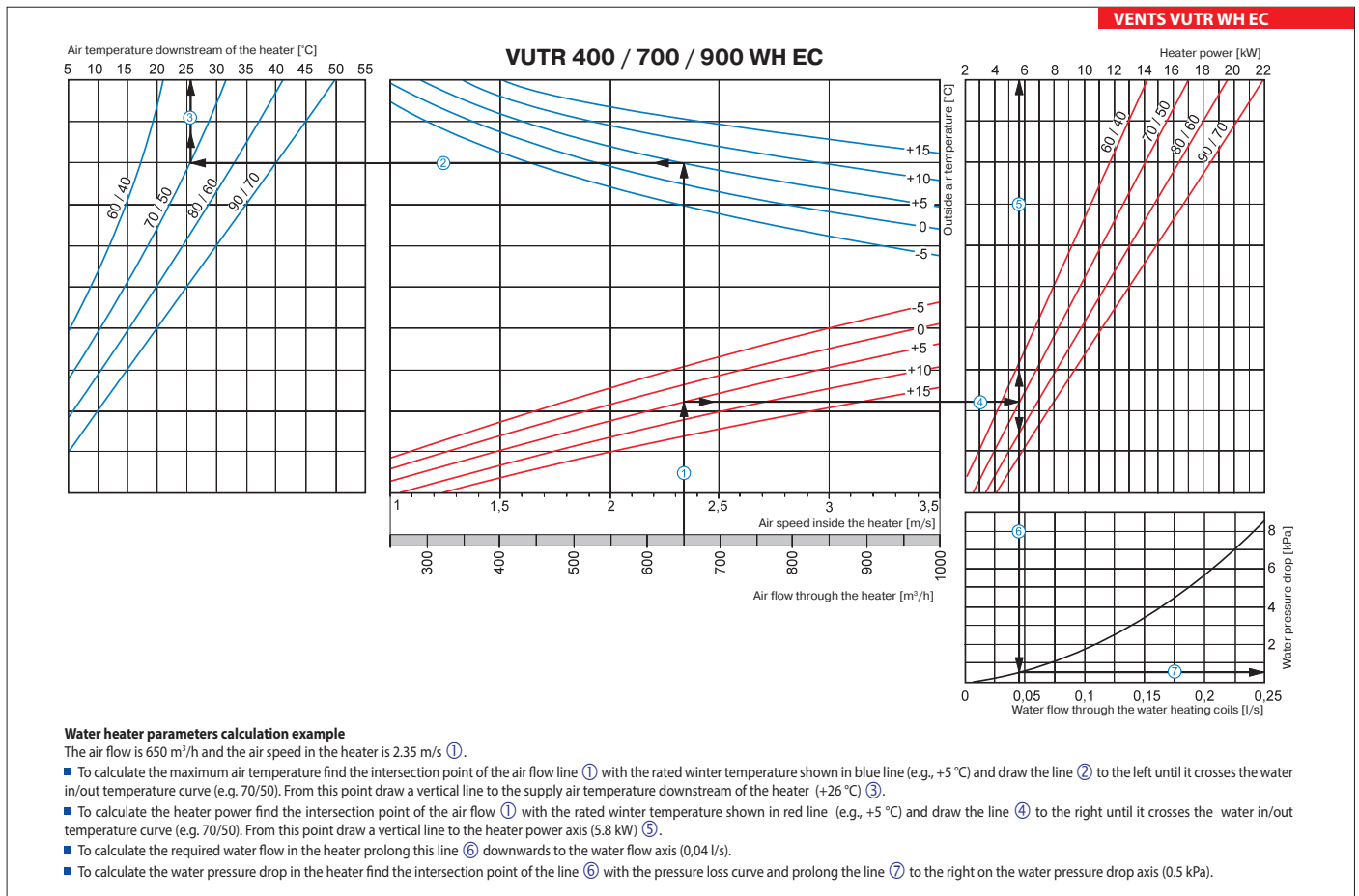

Water heater parameters calculation

VENTS VUTR WH EC

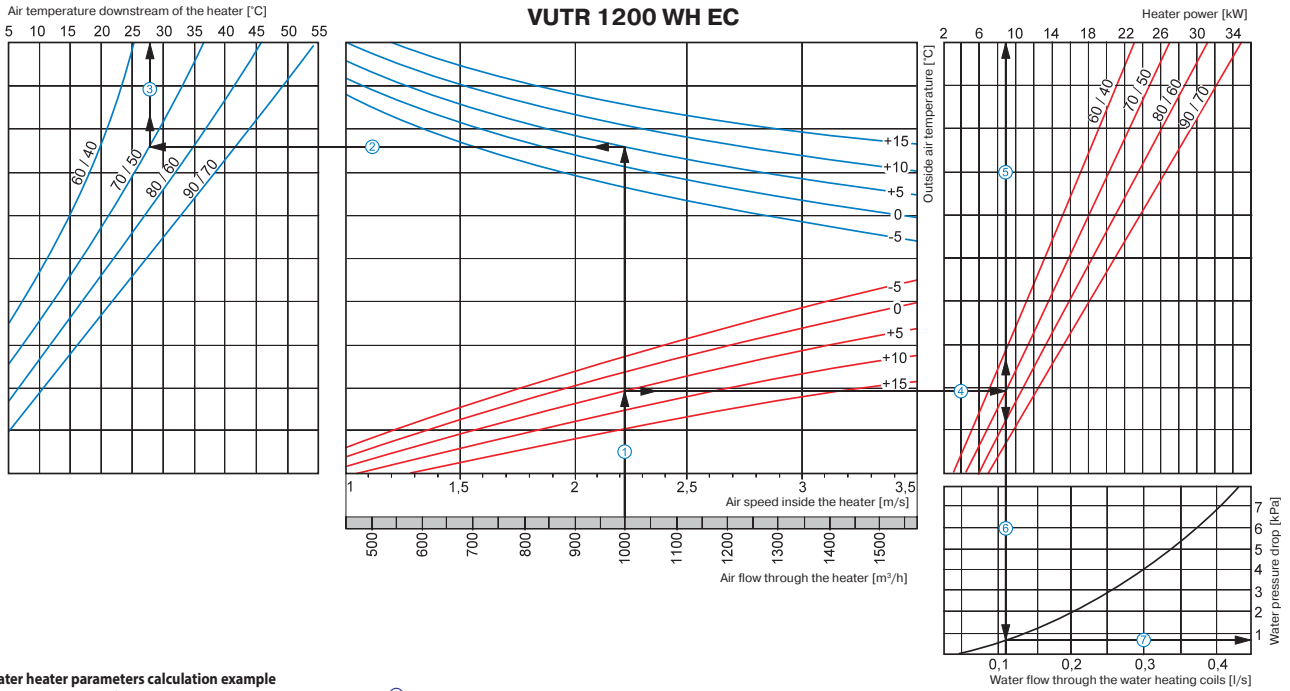

Water heater parameters calculation example

The air flow is 1000 m³/h and the air speed in the heater is 2.22 m/s ①.

- To calculate the maximum air temperature find the intersection point of the air flow line ① with the rated winter temperature shown in blue line (e.g., +5 °C) and draw the line ② to the left until it crosses the water in/out temperature curve (e.g. 70/50). From this point draw a vertical line to the supply air temperature downstream of the heater (28 °C) ③.
- To calculate the heater power find the intersection point of the air flow ① with the rated winter temperature shown in red line (e.g., +5 °C) and draw the line ④ to the right until it crosses the water in/out temperature curve (e.g. 70/50). From this point draw a vertical line to the heater power axis (9.0 kW) ⑤.
- To calculate the required water flow in the heater prolong this line ⑤ downwards to the water flow axis (0.11 l/s).
- To calculate the water pressure drop in the heater find the intersection point of the line ⑥ with the pressure loss curve and prolong the line ⑦ to the right on the water pressure drop axis (0.8 kPa).

VENTS VUTR WH EC

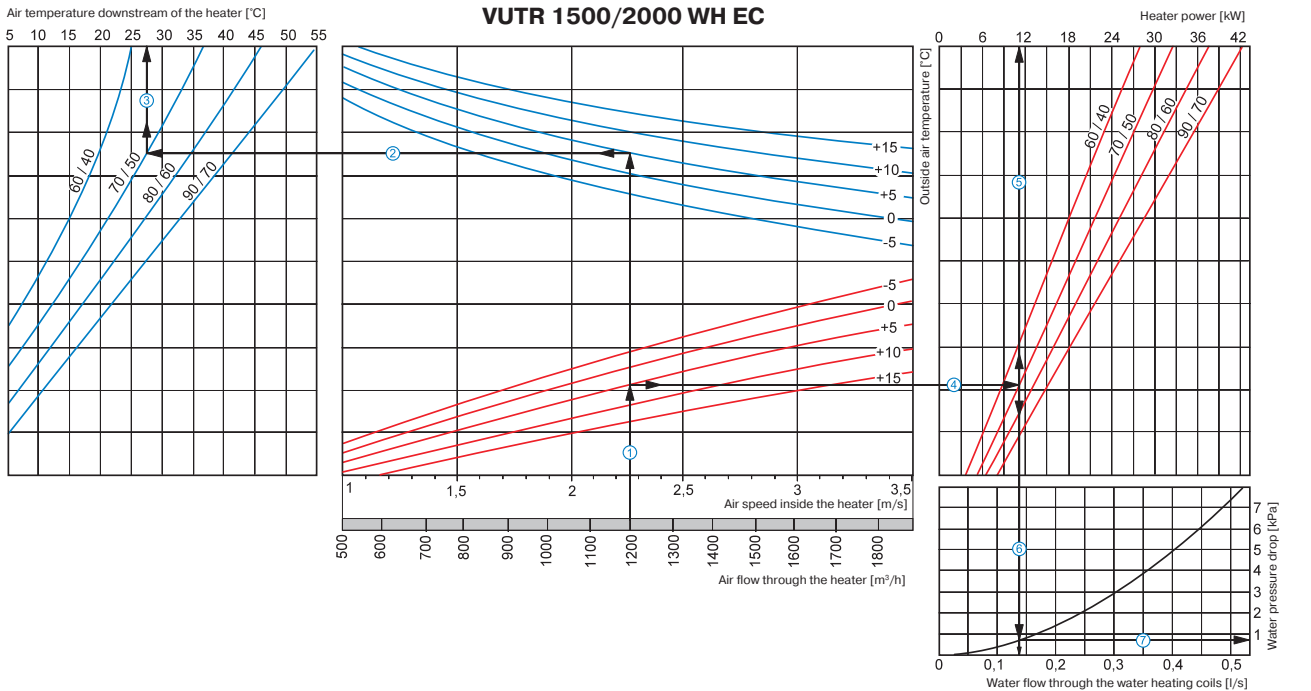

Water heater parameters calculation example

The air flow is 1200 m³/h and the air speed in the heater is 2.25 m/s ①.

- To calculate the maximum air temperature find the intersection point of the air flow line ① with the rated winter temperature shown in blue line (e.g., +5 °C) and draw the line ② to the left until it crosses the water in/out temperature curve (e.g. 70/50). From this point draw a vertical line to the supply air temperature downstream of the heater (27 °C) ③.
- To calculate the heater power find the intersection point of the air flow ① with the rated winter temperature shown in red line (e.g., +5 °C) and draw the line ④ to the right until it crosses the water in/out temperature curve (e.g. 70/50). From this point draw a vertical line to the heater power axis (11.0 kW) ⑤.
- To calculate the required water flow in the heater prolong this line ⑤ downwards to the water flow axis (0.13 l/s).
- To calculate the water pressure drop in the heater find the intersection point of the line ⑥ with the pressure loss curve and prolong the line ⑦ to the right on the water pressure drop axis (0.8 kPa).

AIR HANDLING UNITS WITH HEAT RECOVERY

Accessories for air handling units

Model	G4 supply pocket filter	G4 extract panel filter	Module Modbus-RS485	Outdoor air quality sensor	Outdoor CO ₂ sensor	Outdoor humidity sensor	Outdoor humidity sensor	Indoor humidity sensor (0-10 V)	Mixing unit	Back valves	Air damper	Electric actuator
VUTR 400 EH EC	SFK	SF							-			CM230
VUTR 400 WH EC	393x235x27 G4	600x324x48 G4							USVK 3/4-4	KOM 160	KRV 160	TF230
VUTR 700 EH EC									-			CM230
VUTR 700 WH EC	SFK	SF							USVK 3/4-4	KOM 250	KRV 250	TF230
VUTR 900 EH EC	700x333x27 G4	700x332x48 G4							-			CM230
VUTR 900 WH EC									USVK 3/4-4			TF230
VUTR 1200 EH EC	SFK	SF	PCOS004850	DPWQ 30600	DRWQ 40200	DPWC 11200	HR-S	HV-2	-			CM230
VUTR 1200 WH EC	700x423x27 G4	700x410x48 G4							USVK 3/4-4			TF230
VUTR 1500 EH EC									-	KOM 315	KRV 315	CM230
VUTR 1500 WH EC	SFK	SF							USVK 1-6			TF230
VUTR 2000 EH EC	800x477x27 G4	800x477x47 G4							-			CM230
VUTR 2000 WH EC									USVK 1-6	KOM1 500x300	KR 500x300	TF230

Application options

