

NKD Series



Duct heater for supply air post-heating with external control

Application

The heater is designed for integration into a ventilation system and joint operation with an air handling unit equipped with a control system used to switch on the heater and control its operation.

The heater maintains the supply duct air temperature at a point set by the unit controller.

Design

The casing, the junction box and the heater cover are made of galvanized steel with the heating elements in stainless steel. The heater casing is additionally heat-insulated with 20 mm non-flammable mineral wool layer. The heaters are equipped with rubber seals for airtight connection to the air ducts.

The NKD duct heaters are equipped with a power and a signal cable for connection of the heater to the air handling unit controller.

The temperature is controlled by a triac power controller by means of switching the full load on and off.

Load commutation is carried out by the semiconductor device (triac).

The heaters are equipped with overheat thermostats:

- ▶ main overheat protection with automatic reset at +50 °C
- ▶ emergency overheat protection with manual reset at +90 °C

Mounting

The heater design ensures its mounting on the round ducts in any position by means of clamps (included in delivery).

The air flow direction shall match the direction of the arrow on the heater casing.

The heater is connected to the air handling unit controller using the cable with connectors.

In case of horizontal mounting the control box must be installed with the cover upwards.

Swivel range from the normal position up to max. 90°.

Do not install the control box with the cover downwards.

Overall dimensions of the units

Model	Dimensions [mm]					Weight [kg]
	Ø D	B	H	L	L1	
NKD 125-0,6-1						
NKD 125-0,8-1	124	155	251	306	190	2.1
NKD 125-1,2-1						
NKD 150-0,8-1						
NKD 150-1,2-1	149	170	282	306	190	2.3
NKD 150-1,7-1						
NKD 150-2,0-1						
NKD 160-0,8-1						
NKD 160-1,2-1	159	175	293	306	190	2.5
NKD 160-1,7-1						
NKD 160-2,0-1						
NKD 200-1,2-1						
NKD 200-1,7-1	199	195	337	306	190	2.8
NKD 200-2,0-1						

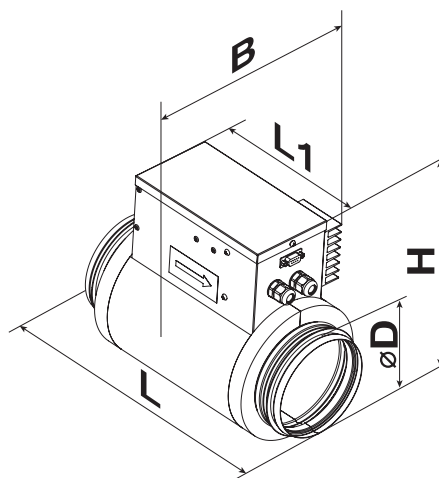

Compatibility chart

Heater model (connected air duct diameter)	
NKD 125	VUT/VUE with Ø 125 mm spigot and A21 automation
NKD 150	VUT/VUE with Ø 150 mm spigot and A21 automation
NKD 160	VUT/VUE with Ø 160 mm spigot and A21 automation
NKD 200	VUT/VUE with Ø 200 mm spigot and A21 automation

Designation key

Series	Connected air duct diameter [mm]	Heater power [kW]	Phases	Compatibility with automation
NKD	125; 150; 160; 200	0,6; 0,8; 1,2; 1,7; 2,0	1: single-phase	A21: compatible with A21 automation

Technical data

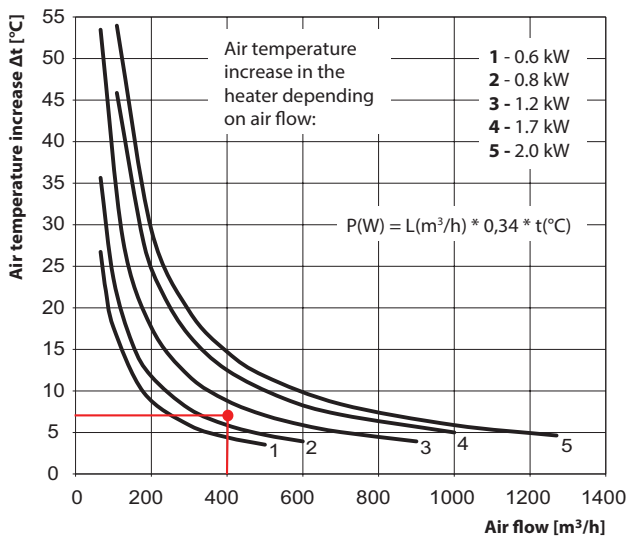

The NKD heater parameters calculation example:

- It is necessary to select a heater for supply air post-heating to a temperature of +24 °C, provided the temperature downstream of the heat exchanger is +17 °C. Therefore, it is essential to increase temperature by 7 °C. The ventilation system incorporates the VENTS VUT 350 VB EC A19 air handling unit. The rated air flow is 400 m³/h. Determine the intersection of the post-heating temperature line (+7 °C) and the rated air flow line (400 m³/h).
- In this case the 1200 W heater capacity provides necessary post-heating (+7 °C). The NKD heater 160-1.2-1 kW with the diameter matching the spigot diameter of the VUT 350 VB EC A19 air handling unit is a suitable model.

Model	Min. air flow [m³/h]	Power [kW]	Current [A]
NKD 125-0,6-1	60	0.6	2.6
NKD 125-0,8-1	80	0.8	3.5
NKD 125-1,2-1	90	1.2	5.2
NKD 150-0,8-1	80	0.8	3.5
NKD 150-1,2-1	90	1.2	5.2
NKD 150-1,7-1	160	1.7	7.4
NKD 150-2,0-1	170	2.0	8.7
NKD 160-0,8-1	80	0.8	3.5
NKD 160-1,2-1	150	1.2	5.2
NKD 160-1,7-1	160	1.7	7.4
NKD 160-2,0-1	170	2.0	8.7
NKD 200-1,2-1	150	1.2	5.2
NKD 200-1,7-1	160	1.7	7.4
NKD 200-2,0-1	170	2.0	8.7

