

VENTS MA Series



Axial fans with automatic louver shutters for exhaust ventilation with the capacity up to 345 m³/h

Application

- Continuous or periodic exhaust ventilation of bathroom, showers, kitchens and other utility spaces.
- Ventilation shaft mounting or duct connection.
- Low to medium air flow motion for short distances at low air resistance.
- Compatible with Ø 100, 125 and 150 mm air ducts.

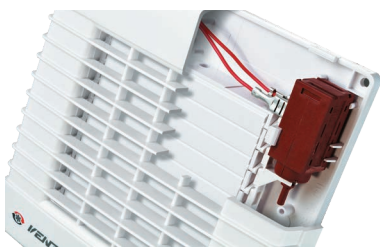

Fan OFF – louver shutters CLOSED



Fan ON – louver shutters OPEN

Design

- Modern design and aesthetic look.
- The casing and the impeller are made of high-quality durable ABS plastic, UV resistant.
- The intellectual impeller design makes the fan efficiency high and the service life long.
- Fan is equipped with a thermal actuator that provides smooth opening and shutting of automatic louver shutters for air back flow preventing.
- Protection rating IP24.

Motor

- Reliable and low-watt electric motor.
- Designed for continuous operation and requires no maintenance.
- Equipped with overheating protection.

Modifications and Options



MA L – the motor is equipped with ball bearings for long service life (appr. 40 thousand hours) and fan mounting at any angle. The bearings are maintenance-free and contain enough grease for the entire operating period.



MA turbo – high-powered motor.



MA press – 5-blade low-noise impeller with improved aerodynamics for higher fan capacity.



MA 12 – modification with low-voltage motor. 12 V AC power supply.



MAT – equipped with a regulated timer with the operating time from 2 to 30 minutes.



MATH – equipped with a timer with the operating time from 2 to 30 minutes and a humidity sensor with the threshold value from 60 to 90 %.



MAV – equipped with a pull cord switch.



MAVT – equipped with a pull cord switch and a regulated timer with the operating time adjustable from 2 to 30 minutes.



MAVTH – equipped with a pull cord switch, regulated timer with the operating time adjustable from 2 to 30 minutes and a humidity sensor with the operating threshold range from 60 to 90 %.



MATP – equipped with a regulated timer and a motion sensor with the sensitivity area from 1 to 4 m and the detection angle up to 100°.

Control

Manual:

- The fan is controlled by a room light switch. It is not included in the delivery package.
- The fan is controlled by the built-in pull cord switch **V**. Not applied in case of ceiling mounting.

Automatic:

- By the electronic control unit **BU-1-60** (see Electrical Accessories). The control unit is supplied separately.
- By the timer **T** (the built-in turn-off delay timer enables the fan operation within 2 to 30 minutes after the fan switching off).
- By the humidity sensor and timer **TH** (if the humidity level in the room exceeds the sensor threshold adjustable value within 60-90 % the fan switches automatically on and operates until the humidity level drops to the standard level, after that the fan continues operating within the time period according to the timer setting, then shuts down).
- By the motion sensor and the timer **TP** (in case of motion detection the fan switches automatically on and operates within the set time period from 2 to 30 minutes. The motion sensitivity area is up to 4 meters and the maximum detection angle is 100°).

Mounting features

- The fan is mounted directly into the ventilation shaft.
- Flexible duct application is recommended in case of remote location of the ventilation shaft. The air duct is connected to the fan exhaust flange through a clamp.
- Fixed to wall by self-tapping screws.
- Suitable for ceiling mounting.
- Flange of 92 mm length for easy mounting into concrete walls and floor decks up to 100 mm thick.
- For 12 V low-voltage motor fan connection to 220 V/50 Hz power mains use the step-down transformer TRF 220/12-25 that is available upon separate order.

Accessories

Air ducts



Grilles and hoods



Speed controllers



Clamps



Aerodynamic characteristics

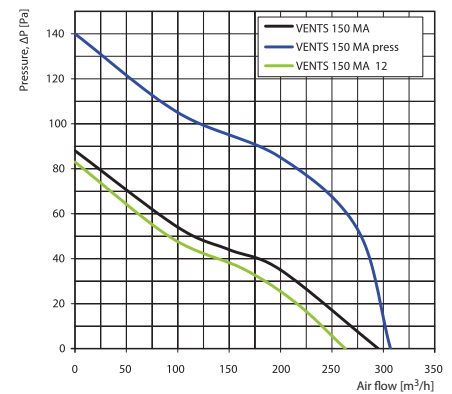
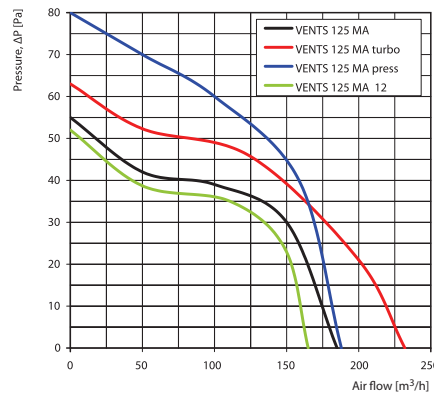
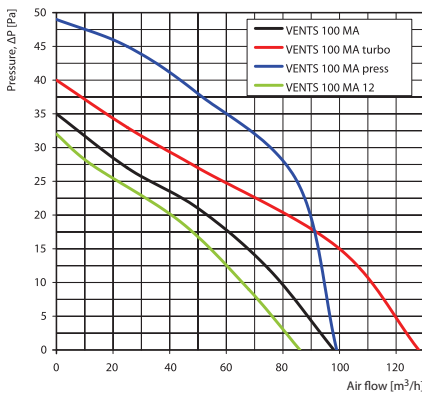

Technical data

Model	Frequency [Hz]	Voltage [V]	Power Consumption [W]	Current [A]	R.p.m.	Maximum air flow [m³/h]	Sound Pressure Level [dBA]*	Weight [kg]
VENTS 100 MA	50	220-240	18	0.085	2300	98	34	0.65
VENTS 100 MA (220 V/60 Hz)	60	220						
VENTS 100 MA turbo	50	220-240	20	0.1	2300	128	37	0.65
VENTS 100 MA turbo (220 V/60 Hz)	60	220						
VENTS 100 MA press	50	220-240	20	0.1	2300	99	37	0.65
VENTS 100 MA press (220 V/60 Hz)	60	220						
VENTS 100 MA 12	50	12	18	1.5	2200	86	33	0.65
VENTS 125 MA	50	220-240	22	0.1	2400	185	35	0.75
VENTS 125 MA (220 V/60 Hz)	60	220						
VENTS 125 MA turbo	50	220-240	29	0.13	2400	232	37	0.81
VENTS 125 MA turbo (220 V/60 Hz)	60	220						
VENTS 125 MA press	50	220-240	29	0.13	2400	188	39	0.81
VENTS 125 MA press (220 V/60 Hz)	60	220						
VENTS 125 MA 12	50	12	22	1.7	2300	165	34	0.75
VENTS 150 MA	50	220-240	26	0.13	2400	295	39	1.02
VENTS 150 MA (220 V/60 Hz)	60	220						
VENTS 150 MA press	50	220-240	32	0.14	2400	307	41	0.99
VENTS 150 MA press (220 V/60 Hz)	60	220						
VENTS 150 MA 12	50	12	29	2	2300	263	38	0.98

*Sound pressure level measured in free space at a distance of 3 meters from the fan.

Mounting example



Overall dimensions

Model	Dimensions [mm]						
	∅D	B	B1	B2	H	L	L1
VENTS 100 MA	100	165	150	150	150	92	32
VENTS 125 MA	125	190	174	128	173	98	33
VENTS 150 MA	150	212	196	150	195	114	33

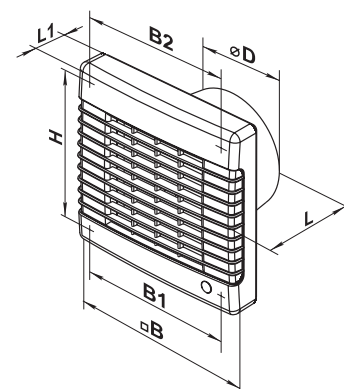

Certificates

The fans meet the applicable safety and electromagnetic compatibility standards.