

Series
SR



Series
SRF



■ **Applications**

Silencer is applied for noise absorption produced during the ventilating equipment operation and spread along the ducting systems. Suitable for installation into round ducts. The silencer reduces the noise level in the air duct significantly (refer the diagram «Noise level reduction»). For designing a ventilation system with low level of noise emission into the environment silencers should be used together with insulated fans.

■ **Design**

The galvanized steel casing of the SR silencer is filled with flameproof sound insulating material and equipped with protecting covering against fiber blowing-out. The SRF silencer casing consists of internal and external aluminium-alloy spiral seam tubes filled with flameproof sound insulating material. The casing inner surface is perforated and has the protecting over to prevent the fiber blowing-out. The minimum bending radius of the silencer is up to 2 diameters. Each standards size has several length modifications.

The SR and SRF silencers are equipped with connecting flanges with rubber sealing for airtight connection to the air ducts.

■ **Mounting**

The silencers can be mounted in any position. Installing several silencers in series is preferable to improve sound absorption effect. To prevent the flexible silencer sagging it should be fixed not only at the ends but also in the middle.

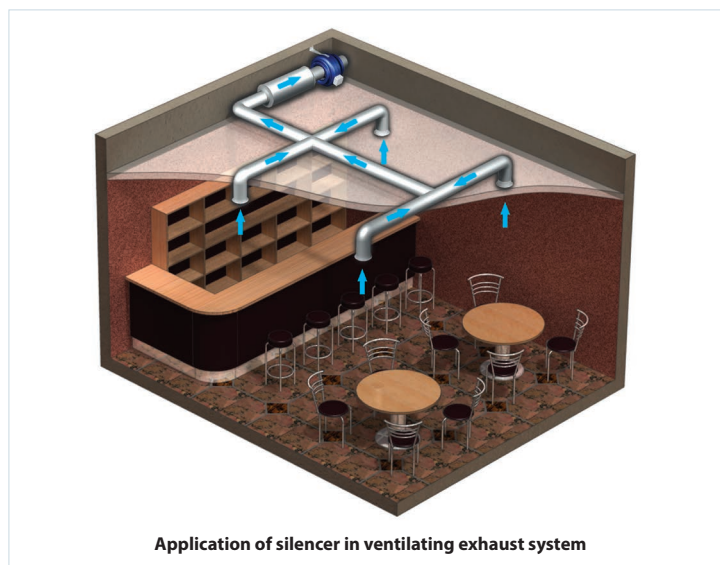

Designation key

Series	Air duct diameter [mm]	Length
SR SRF	100; 125; 150; 160; 200; 250; 315; 355; 400	600; 900; 1200; 2000

	Noise level reduction, dB (Octave-frequency band [Hz])							
	63 Hz	125 Hz	250 Hz	500 Hz	1000 Hz	2000 Hz	4000 Hz	8000 Hz
SR 100/600	4	8	10	20	34	30	13	14
SR 100/900	5	10	15	23	44	30	16	15
SR 100/1200	6	11	19	28	50	34	20	18
SR 125/600	3	5	6	15	28	17	10	9
SR 125/900	4	9	12	22	43	22	16	12
SR 125/1200	4	9	16	27	48	27	21	17
SR 150/600	2	4	8	16	32	11	7	7
SR 150/900	3	5	9	18	36	25	13	14
SR 150/1200	4	8	14	25	43	30	18	19
SR 160/600	2	4	8	17	33	11	7	7
SR 160/900	2	5	10	19	37	25	13	15
SR 160/1200	4	10	14	24	42	30	19	20
SR 200/600	2	4	6	10	27	13	7	7
SR 200/900	3	7	11	20	39	23	8	7
SR 200/1200	4	10	14	23	40	26	13	12
SR 250/600	4	5	6	11	22	12	7	6
SR 250/900	4	5	7	16	32	20	12	10
SR 250/1200	4	6	8	17	34	22	14	12
SR 315/600	2	4	5	10	17	9	6	5
SR 315/900	3	5	8	17	30	14	10	8
SR 315/1200	4	7	11	22	36	18	14	10
SR 355/600	4	9	16	22	17	13	14	13
SR 355/900	7	11	19	25	19	16	17	18
SR 355/1200	10	15	22	27	22	18	20	22
SR 400/900	6	10	18	23	17	15	16	20
SR 400/1200	9	14	21	25	20	17	19	25

	Noise level reduction, dB (Octave-frequency band [Hz])							
	63 Hz	125 Hz	250 Hz	500 Hz	1000 Hz	2000 Hz	4000 Hz	8000 Hz
SRF 100/600	6	8	13	22	28	34	17	20
SRF 100/900	8	10	15	25	33	40	21	23
SRF 100/2000	10	15	24	48	53	51	39	36
SRF 125/600	4	7	14	20	31	31	13	12
SRF 125/900	5	9	16	23	36	37	17	16
SRF 125/2000	7	15	23	47	55	50	28	25
SRF 150/600	3	7	12	32	40	40	19	20
SRF 150/900	4	8	14	40	48	49	26	25
SRF 150/2000	5	10	21	42	50	48	26	25
SRF 160/600	3	7	12	20	25	24	10	12
SRF 160/900	3	8	13	21	28	28	13	16
SRF 160/2000	5	11	20	40	48	48	25	25
SRF 200/600	2	5	12	20	26	21	10	10
SRF 200/900	3	6	12	22	28	24	12	13
SRF 200/2000	4	11	22	42	51	34	19	23
SRF 250/600	2	3	8	16	22	13	10	10
SRF 250/900	2	4	9	18	25	16	11	12
SRF 250/2000	3	6	16	30	39	27	17	22
SRF 315/600	2	4	9	18	21	12	7	9
SRF 315/900	2	5	11	21	24	14	8	10
SRF 315/2000	4	7	17	34	39	24	14	18

Overall dimensions

Type	Dimensions [mm]			Weight [kg]
	∅D	∅D1	L	
SR 100/600	99	202	600	2.9
SR 100/900	99	202	900	4.0
SR 100/1200	99	202	1200	5.2
SR 125/600	125	225	600	3.3
SR 125/900	125	225	900	4.6
SR 125/1200	125	225	1200	5.9
SR 150/600	149	252	600	3.7
SR 150/900	149	252	900	5.1
SR 150/1200	149	252	1200	6.5
SR 160/600	159	252	600	3.7
SR 160/900	159	252	900	5.1
SR 160/1200	159	252	1200	6.5
SR 200/600	198	318	600	4.65
SR 200/900	198	318	900	6.45
SR 200/1200	198	318	1200	8.1
SR 250/600	248	358	600	5.6
SR 250/900	248	358	900	7.8
SR 250/1200	248	358	1200	10
SR 315/600	313	403	600	7.1
SR 315/900	313	403	900	10.1
SR 315/1200	313	403	1200	13
SR 355/600	353	453	600	8.3
SR 355/900	353	453	900	11.6
SR 355/1200	353	453	1200	14.9
SR 400/600	398	503	600	10,75
SR 400/900	398	503	900	14.5
SR 400/1200	398	503	1200	18.2

Type	Dimensions [mm]			Weight [kg]
	∅D	∅D1	L	
SRF 100/600	99	220	600	1.6
SRF 100/900	99	220	900	2.4
SRF 100/2000	99	220	2000	5.2
SRF 125/600	124	270	600	2.0
SRF 125/900	124	270	900	3.0
SRF 125/2000	124	270	2000	6.6
SRF 150/600	149	270	600	2.1
SRF 150/900	149	270	900	3.1
SRF 150/2000	149	270	2000	6.8
SRF 160/600	159	270	600	2.1
SRF 160/900	159	270	900	3.2
SRF 160/2000	159	270	2000	7.0
SRF 200/600	199	320	600	2.6
SRF 200/900	199	320	900	3.9
SRF 200/2000	199	320	2000	8.6
SRF 250/600	249	370	600	3.0
SRF 250/900	249	370	900	4.5
SRF 250/2000	249	370	2000	10.1
SRF 315/600	314	420	600	3.4
SRF 315/900	314	420	900	5.1
SRF 315/2000	314	420	2000	11.4

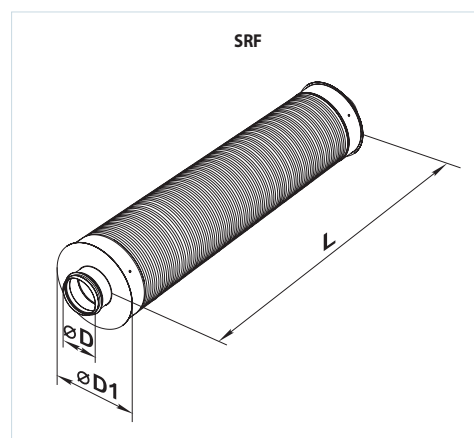
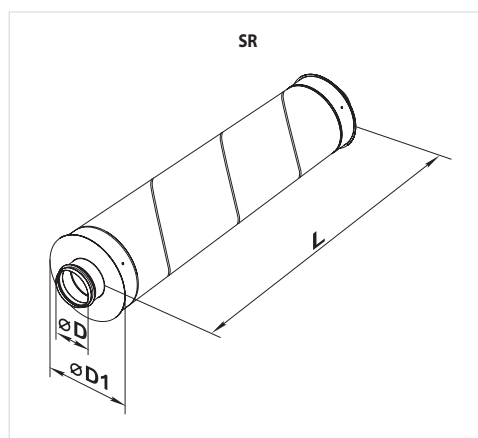

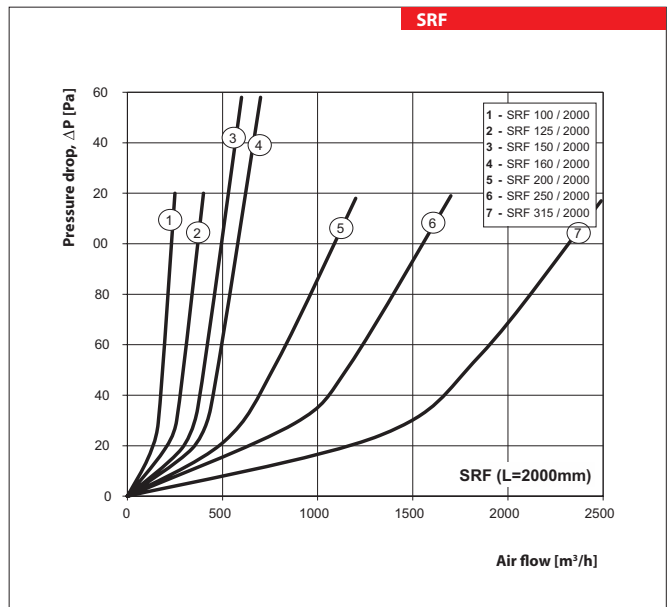
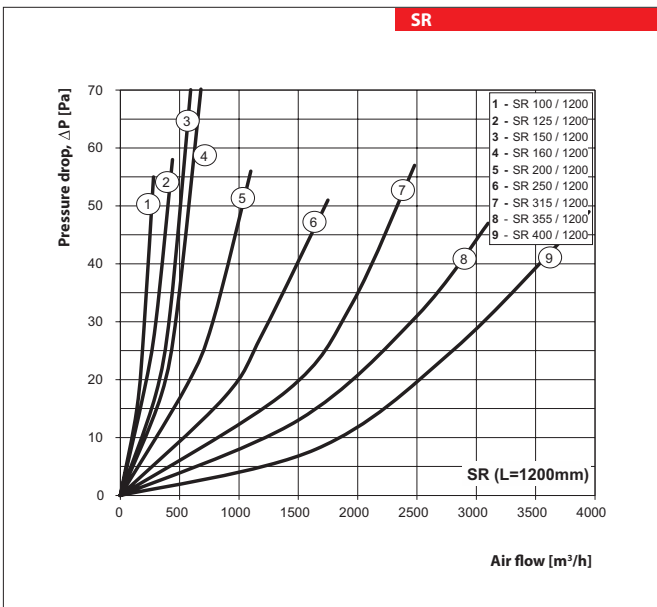
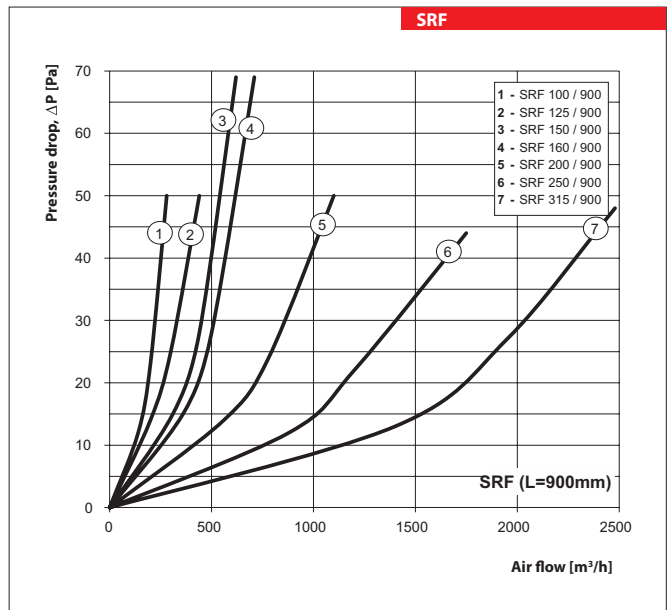
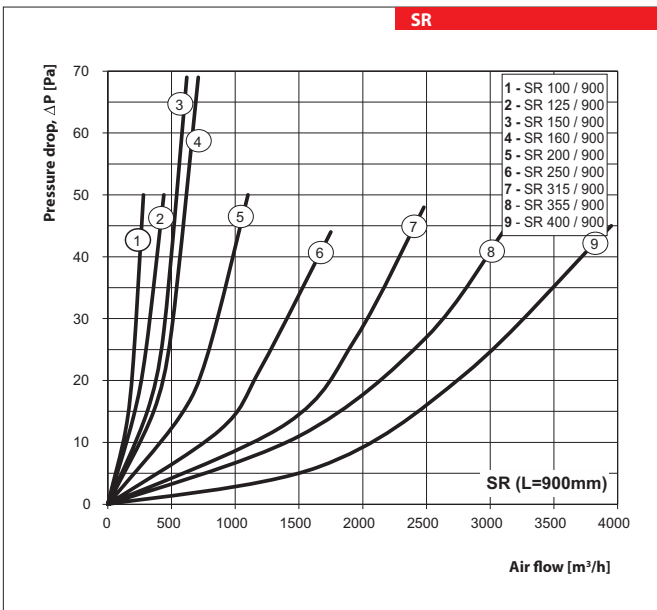
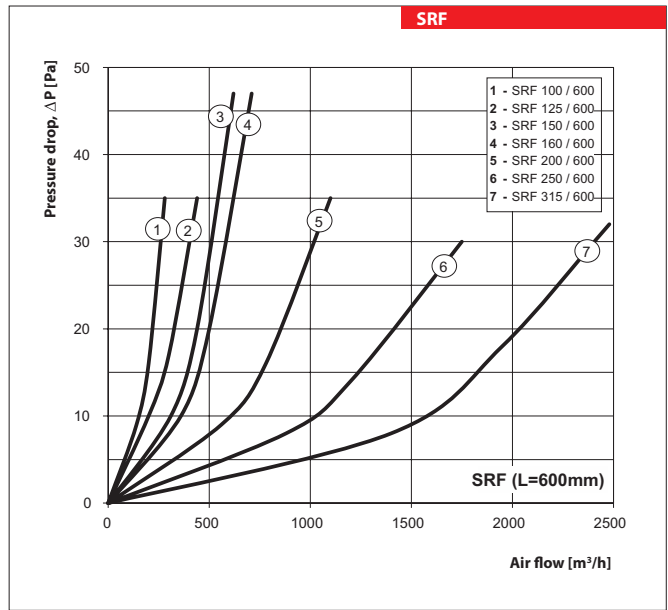
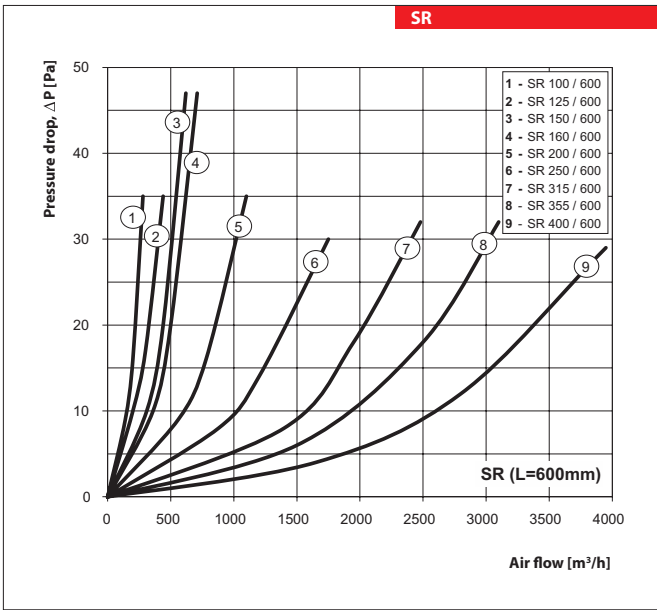

SR
SRF
SILENCER