

Series
VENTS Boost-I



Inline mixed-flow fans in sound- and heat-insulated casing.
Air flow up to **3185 m³/h**.

Application

The inline VENTS Boost-I fans are enclosed in a specially designed sound-insulated casing that ensures silent fan operation in combination with high aerodynamic characteristics. The fans are compatible with round air ducts Ø 200, 250, 315, 355, 400 mm.

The VENTS Boost-I fans are recommended as a component of the air handling systems for various commercial and industrial premises with high requirements to noise level, i.e. libraries, conference halls, educational institutions, kindergartens, etc.

Design

The external casing is made of galvanized steel. Sound and heat insulation is provided by 30 mm acoustic material.

Due to the improved mixed type impeller, which is a hybrid of axial and centrifugal impeller, the Boost-I has low power consumption and noise level with high performance.

The fan casing is equipped with an airtight terminal box for connection to power mains.

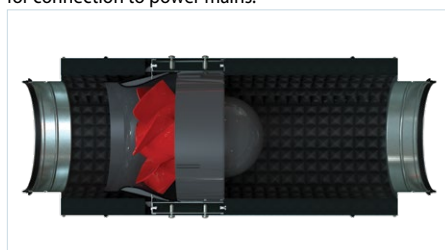

Motor

The VENTS Boost-I fans are equipped with single-phase high-efficiency three-speed asynchronous motors with low power consumption. The motor is equipped with

thermal switches for overheating protection. The ball bearings ensure a long service life (about 40 000 hours of continuous operation). The motor ingress protection rating is IPX4.

Speed control

The three-speed motor can be controlled using a built-in switch (option V) or an external switch or speed controller (purchased separately).

Mounting

The unit is intended for mounting to round air ducts. The fan is installed in the gap between the air ducts. The fan casing has mounting brackets to facilitate suspended installation of the fan. While installing the fan, ensure convenient access for subsequent maintenance and repair. Electrical connection and installation must be performed in accordance with the instruction manual and the electrical connections diagram applied to the terminal box. A single system may have several fans installed in parallel to boost the output capacity or in series to boost the working pressure.

Fan overall dimensions

Type	Dimensions [mm]					Weight [kg]
	ØD	ØD1	L	L1	B	
Boost-I 200	199	281	601	739	339	8.2
Boost-I 250	249	337	601	739	389	9.8
Boost-I 315	314	412	601	739	468	20.7
Boost-I 355	354	412	601	739	471	20.7
Boost-I 400	399	460	648	785	517	22.8

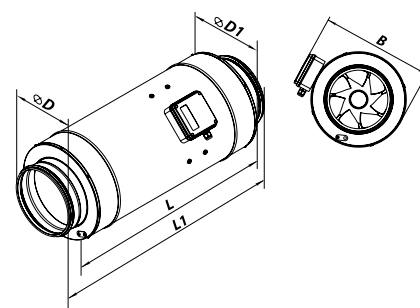

Designation key

Series	Air duct diameter	Options
VENTS Boost-I	200; 250; 315, 355, 400	<p>T: turn-off delay timer adjustable from 2 to 30 minutes.</p> <p>U: speed controller with an electronic thermostat and a temperature sensor integrated inside an air duct. Temperature-based operation logic.</p> <p>Un: speed controller with an electronic thermostat and a temperature sensor fixed on a 4-meter cable. Temperature-based operation logic.</p> <p>R: power cord with a mains plug.</p> <p>V: three-position speed switch.</p>

Accessories



Technical data

	BOOST-I 200			BOOST-I 250		
	min	mid	max	min	mid	max
Speed						
Voltage [V]	1~230					
Frequency [Hz]	50					
Power [W]	82	104	113	144	173	188
Current [A]	0.37	0.46	0.51	0.70	0.81	0.84
Max. air flow [m³/h]	692	906	1110	1007	1404	1670
Max. air flow [l/s]	192	252	308	280	390	464
RPM [min ⁻¹]	2229	2634	2823	2292	2626	2876
Noise level at 3 m [dBA]	37	42	44	38	43	45
Transported air temperature [°C]	-25...+55					
Protection rating	IPX4					
Motor protection rating	IP20					

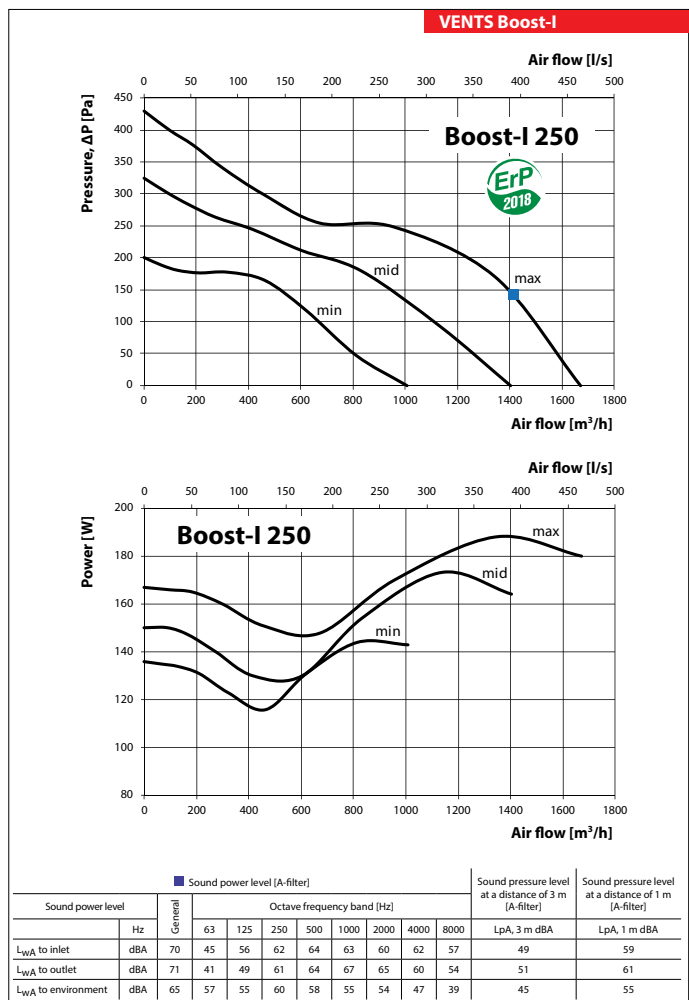
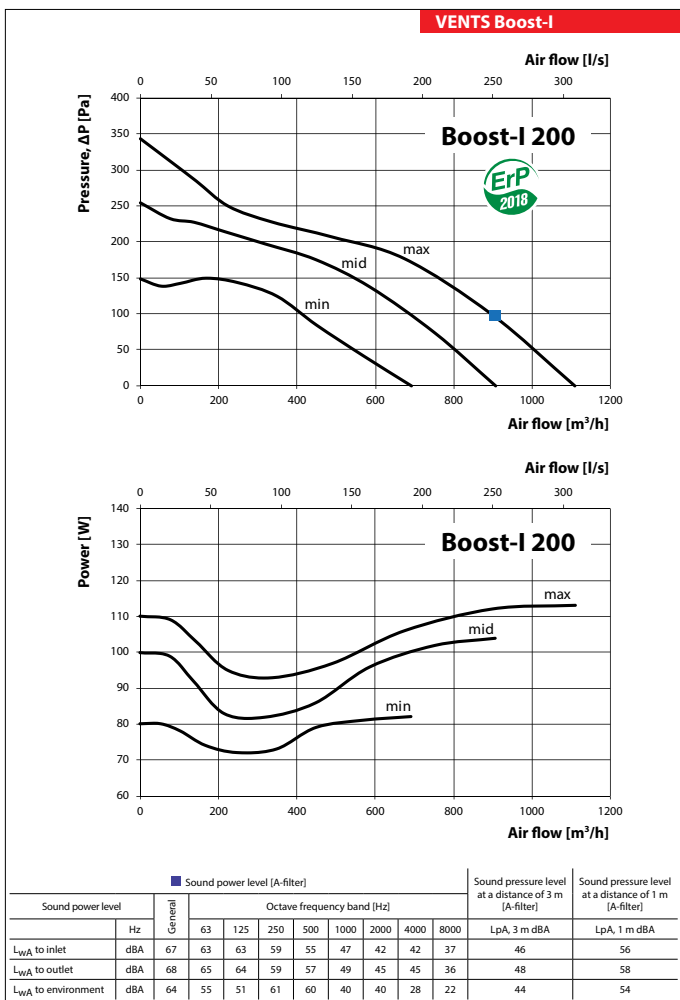

VENTS BOOST-I
FAN SERIES

SOUND-INSULATED FANS

Technical data

	BOOST-I 315			BOOST-I 355		
Speed	min	mid	max	min	mid	max
Voltage [V]	1~230					
Frequency [Hz]	50					
Power [W]	126	131	148	126	131	150
Current [A]	0.60	0.458	0.66	0.60	0.58	0.66
Max. air flow [m³/h]	1913	2120	2300	1986	2170	2360
Max. air flow [l/s]	531	589	639	552	603	656
RPM [min ⁻¹]	1350	1400	1470	1350	1400	1470
Noise level at 3 m [dBA]	33	34	36	33	34	36
Transported air temperature [°C]	-25...+55					
Protection rating	IPX4					
Motor protection rating	IP20					

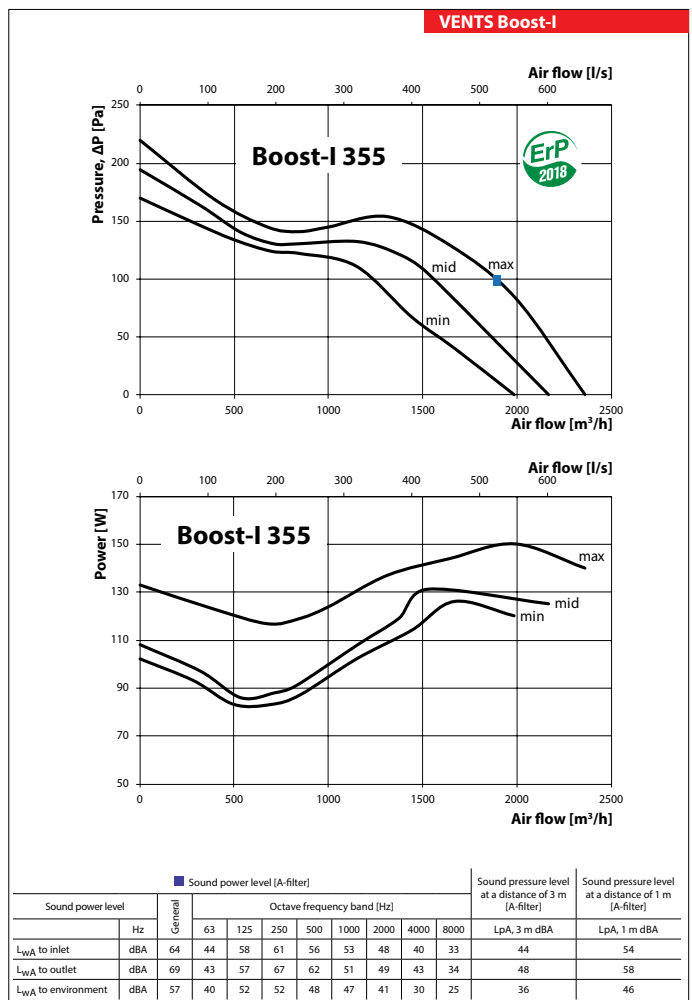
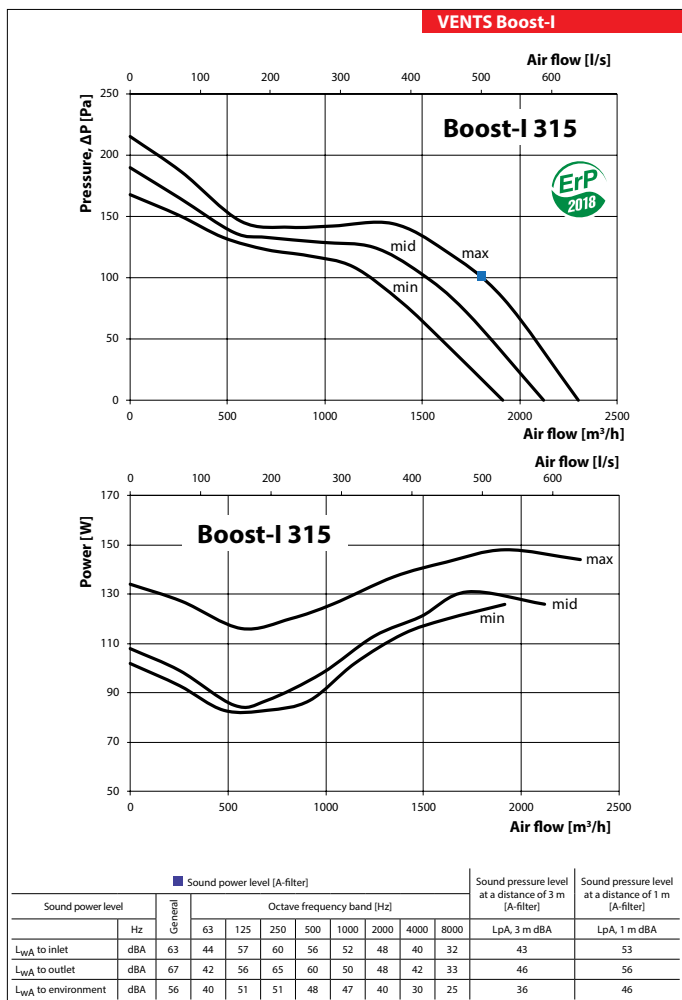

Technical data

	BOOST-I 400		
	min	mid	max
Speed			
Voltage [V]		1~230	
Frequency [Hz]		50	
Power [W]	197	204	224
Current [A]	0.91	0.90	0.98
Max. air flow [m³/h]	2543	2979	3185
Max. air flow [l/s]	706	828	885
RPM [min ⁻¹]	1320	1390	1446
Noise level at 3 m [dBA]	34	35	37
Transported air temperature [°C]		-25...+55	
Protection rating		IPX4	
Motor protection rating		IP20	

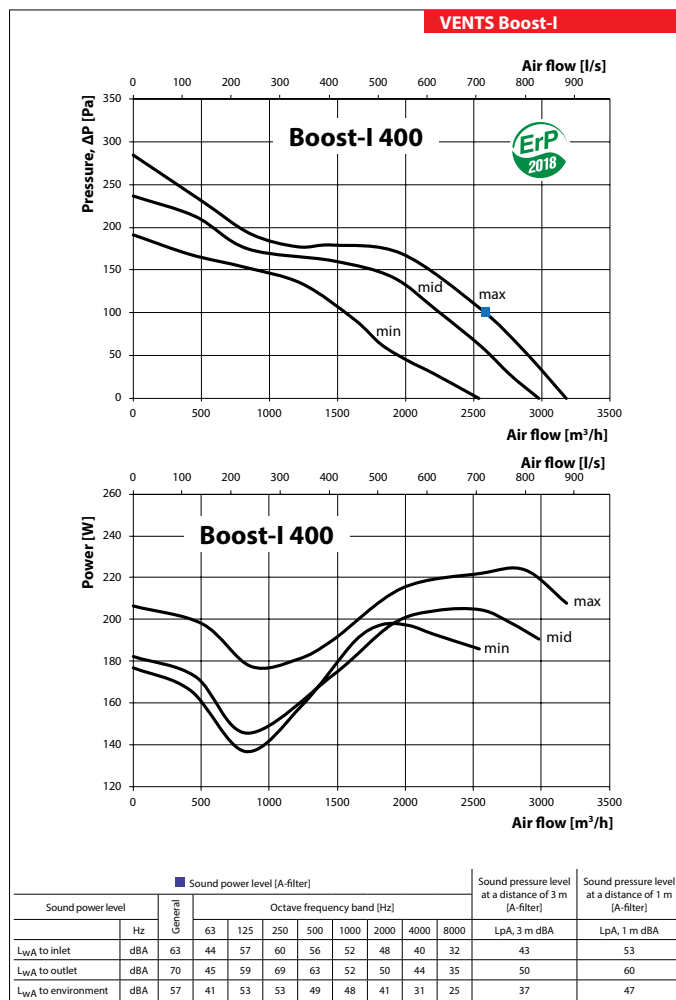

VENTS BOOST-I
FAN SERIES