

DRAIN PUMP

DN-2



Application

Condensate may form in the heat exchanger during heat recovery. The drain pump provides extraction and discharge of condensate in ventilation systems.

Mounting

The condensate drain pan should only be mounted in a horizontal position. The drain pump can be installed both horizontally and vertically. See the User's manual for more details.

Design

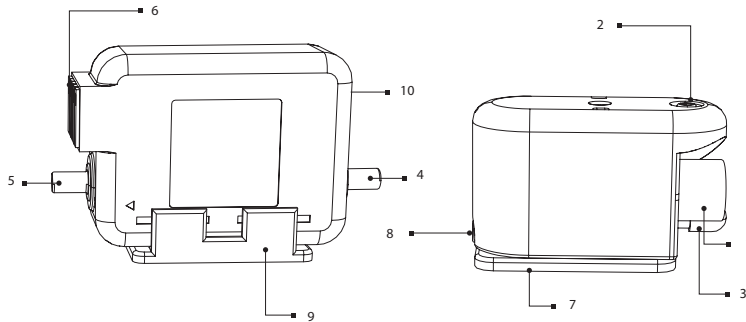

- 1 – condensate water inlet
- 2 – air intake fitting for Ø4x6 hose
- 3 – condensate outlet fitting
- 4, 8 – fitting for Ø4x6 connecting hose
- 5 – fitting for a drain pipe
- 6 – removable terminal block
- 7 – mounting plate
- 9 – pump lock
- 10 – removable electric cable socket

Technical data

Air flow [l/h]	7
Water lifting at inlet (evacuation) [m]	2
Water lifting at outlet (delivery) in vertical direction [m]	7
Voltage [V/Hz]	230/50
Noise level [dBA]	21
Power [W]	19
C – NO signal contact parameters [A]	8

Overall dimensions

Model	Dimensions [mm]								
	ØD2	ØD1	A	A1	A2	H	H1	L	L1
DN-2	18	5	68	68	82	55	38	32	30

