

Drainage Pump Box DN-2-DVUT-P



PURPOSE

The product is designed for condensate drainage from the unit to the sewage system.

DELIVERY SET

Name	Quantity
The product	1 pc.
Installation manual	1 pc.
Mounting screws	3 pcs.

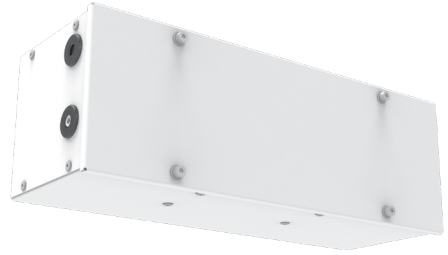

OVERALL DIMENSIONS

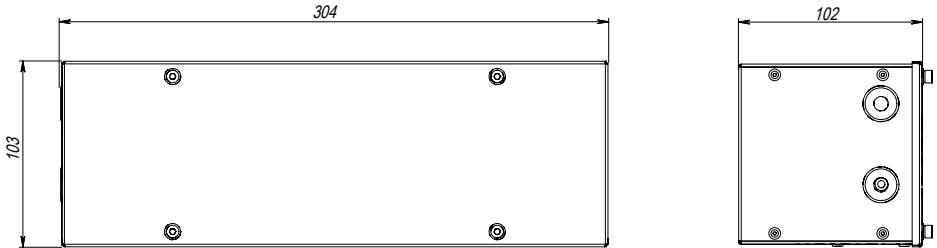

INSTALLATION AND SET-UP

The product is attached to the unit using mounting self-tapping screws. To do this, remove the front panel of the product. Align the inlet of the product with the drainage outlet of the unit. Attach the product to the unit as shown in the diagram.

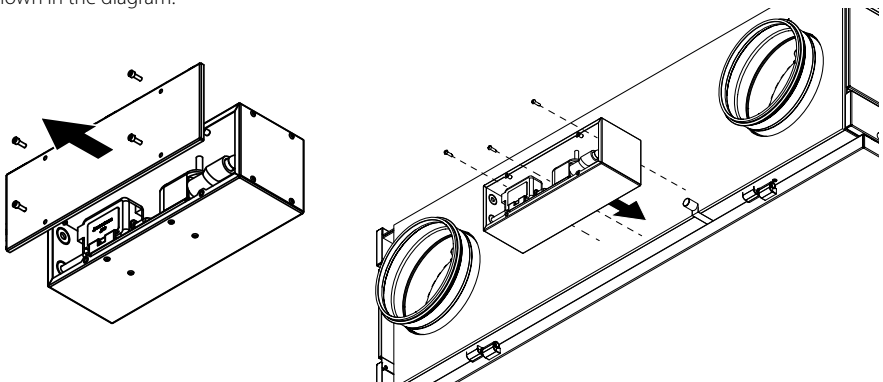

The drainage pump is connected to the power supply and to the sewage system through the product's cable glands according to the user manual for the drainage pump. .