

FLUSH-MOUNTED DIFFUSER SERIES

DP-RC 125
DP-RC 150
DP-RC 160
DP-C 125
DP-C 150
DP-C 160



Flush-mounted diffusers DP-RC/C made of eco-friendly high-density foam are a perfect solution for rooms of different designs and purposes as they are almost unnoticeable on the ceiling, they have stylish appearance and can be painted to match the necessary color.

Round and square panel shapes are available to match the room's geometry.

Connection to 125, 150 or 160 mm air ducts allows to arrange the necessary air distribution.

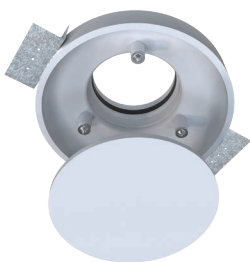

The magnetic decorative panel ensures easy and fast maintenance



The diffusers are installed in suspended ceiling and easily connected to various air duct systems

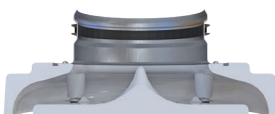

Pressure loss is minimized due to the aerodynamic shape



Eight-segmented air flow regulator enables adjusting the necessary air flow (delivered separately)

Assortment



DP-RC 125



DP-RC 150/160



DP-C 125



DP-C 150/160

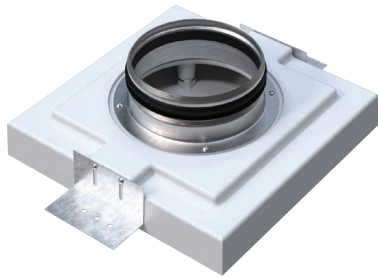

Metal flange (MF) with a rubber seal to be connected to air ducts or mounting elements

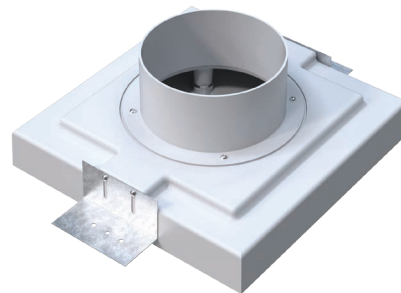

Plastic flange (by default) to be connected to rigid or flexible ducts

Model	Dimensions [mm]								
	D	D1	D2	L	L1	L2	H	H1	B
DP-RC 125	125	250	234	323	-	-	108	59	80
DP-RC 125 MF	124	250	234	323	-	-	99	50	80
DP-RC 150	150	300	241	374	-	-	117	59	80
DP-RC 150 MF	149	300	241	374	-	-	108	50	80
DP-RC 160 MF	157	300	241	374	-	-	108	50	80
DP-C 125	125	-	-	329	250	208	108	59	80
DP-C 125 MF	124	-	-	329	250	208	99	50	80
DP-C 150	150	-	-	379	300	255	118	59	80
DP-C 150 MF	149	-	-	379	300	255	108	50	80
DP-C 160 MF	157	-	-	379	300	255	108	50	80

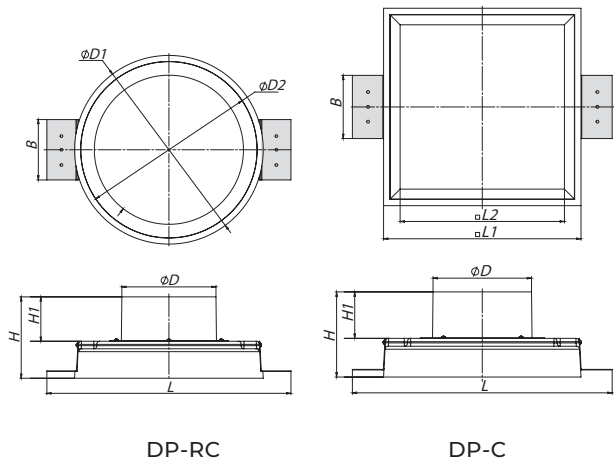

Aerodynamic data

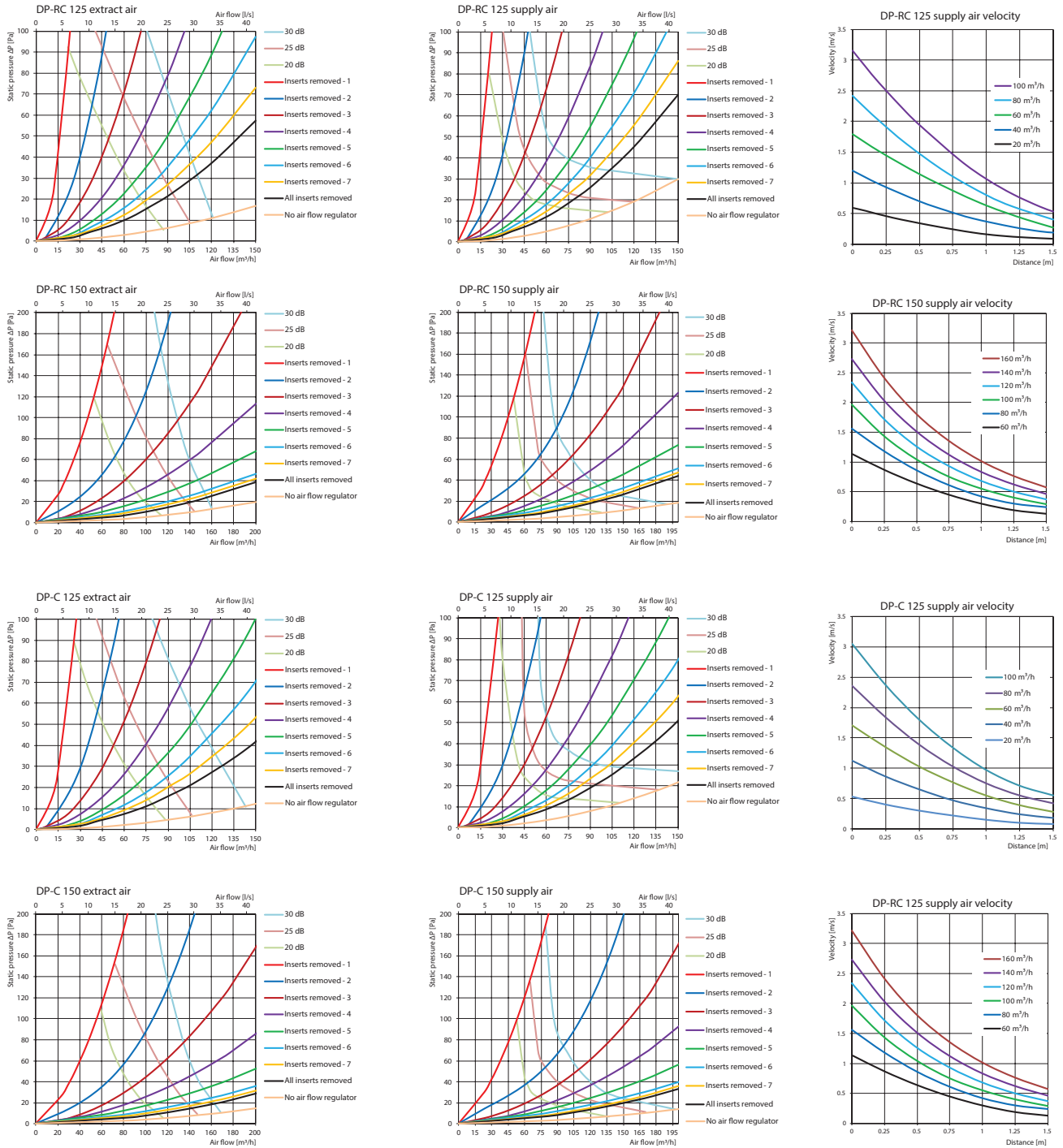

* The data is provided for the diffuser equipped with an F4 125 FB air flow regulator



The brochure information is for reference only.

VENTS reserves the rights to modify any of its products' features, designs, components and specifications at any time and without notice to maintain the development and quality of manufactured goods.

2024-07