

FB K2 UV series

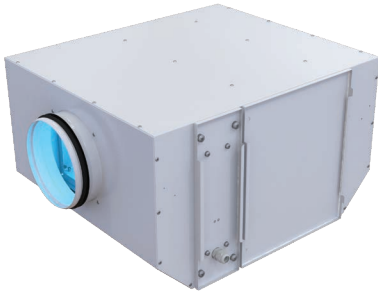

Application

Filter boxes are designed for use in supply ventilation and conditioning systems requiring high level of air purification and disinfection. Designed for connection to ø150, 160 and 200 mm round air ducts.

Design

Corrosion resistant casing made of polymer coated steel. Convenient access for UV lamp and filter replacement.

Mounting

The compact design offers the ideal mounting solutions for limited mounting space, including suspended ceiling mounting.

Wall or ceiling mounting is performed by means of the supplied mounting brackets.

The filter can be installed in any position.

Air filtration

The service panel in the casing enables quick access to the filters. Pre-filtering with G4 filter. Secondary cleaning is provided by F8 filter or H13 HEPA filter.

F8 filter delays up to 95 % of solid particles with a diameter of 0.4 microns.

H13 filter delays up to 99 % of solid particles with a diameter of less than 0.4 microns, as well as fluff and bacteria.

For additional removal of unwanted odours and gases, it is possible to install a carbon filter.

UV lamp

The UV lamp with a wavelength of 256 nm cleans the air passing through the filter box from viruses and bacteria.

The detachable lamp unit can be easily removed for maintenance or replacement thanks to a special service panel.

The service life of UV lamps is up to 8000 hours.

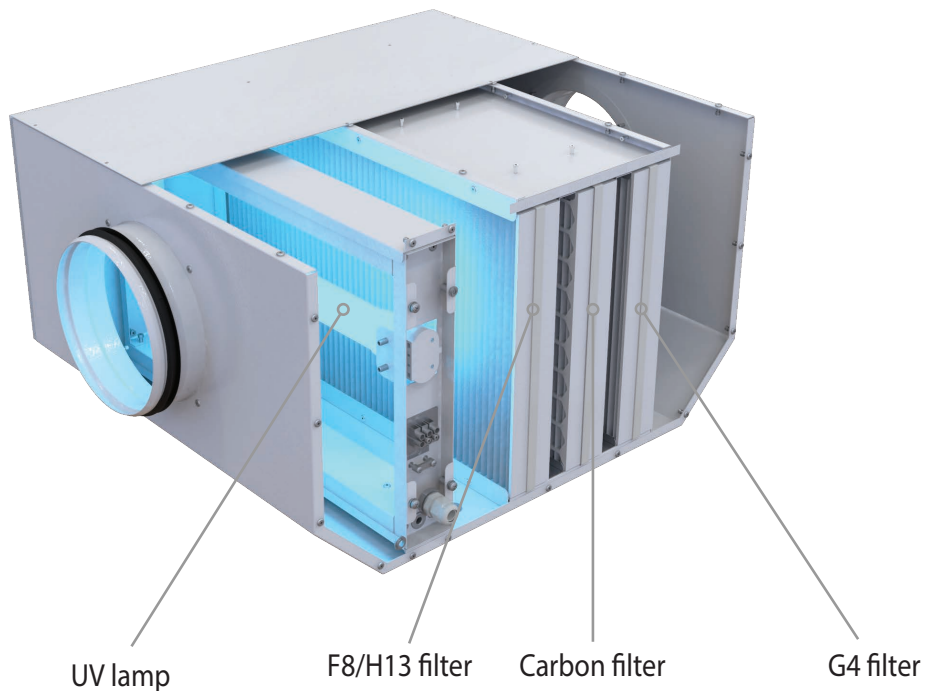

Designation key

Series	Spigot diameter [mm]	Filters	UV lamp
FB K2	150; 160; 200	G4/F8: G4 + F8 filters G4/C/F8: G4 + Carbon + F8 filters G4/H13: G4 + H13 filters G4/C/H13: G4 + Carbon + H13 filters	UV

Overall dimensions

Model	D	L	H	B	L1	B1	L2	B2	Weight [kg]
FB K2 150 G4/F8 UV									12.4
FB K2 150 G4/C/F8 UV									13.3
FB K2 150 G4/H13 UV	147	513.5	299	440	611	533	458.5	484	12.4
FB K2 150 G4/C/H13 UV									13.3
FB K2 150 UV									11.9
FB K2 160 G4/F8 UV									13.9
FB K2 160 G4/C/F8 UV									14.8
FB K2 160 G4/H13 UV	157	513.5	299	440	611	533	458.5	484	13.9
FB K2 160 G4/C/H13 UV									14.8
FB K2 160 UV									13.4
FB K2 200 G4/F8 UV									17.2
FB K2 200 G4/C/F8 UV									18.5
FB K2 200 G4/H13 UV	197	513.5	299	605	611	698	458.5	649	17.2
FB K2 200 G4/C/H13 UV									18.5
FB K2 200 UV									16.6

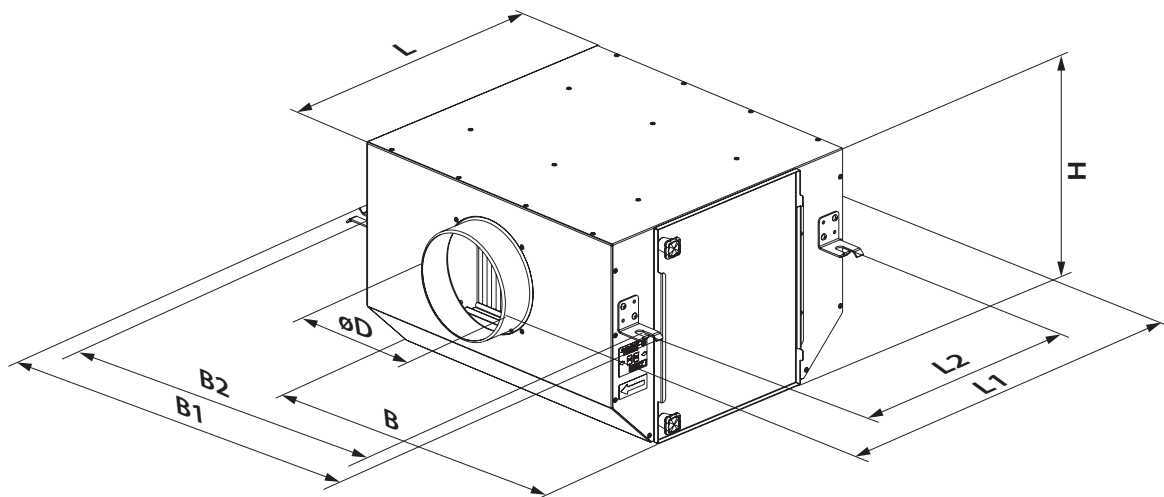

PANEL FILTERS

	FB K2 150/160 UV	FB K2 200 UV
OSRAM lamp model	HNS L 60 W 2G11	HNS L 95 W 2G11
Supply voltage, 50 (60) Hz [V]	1~230	1~230
Power [W]	60	95
Rated current [A]	0.8	0.8
Starting current [A]	40	40
Radiation power (UVC) [W]	19	27
Lamp dimensions [mm]	408 x 40	533 x 40

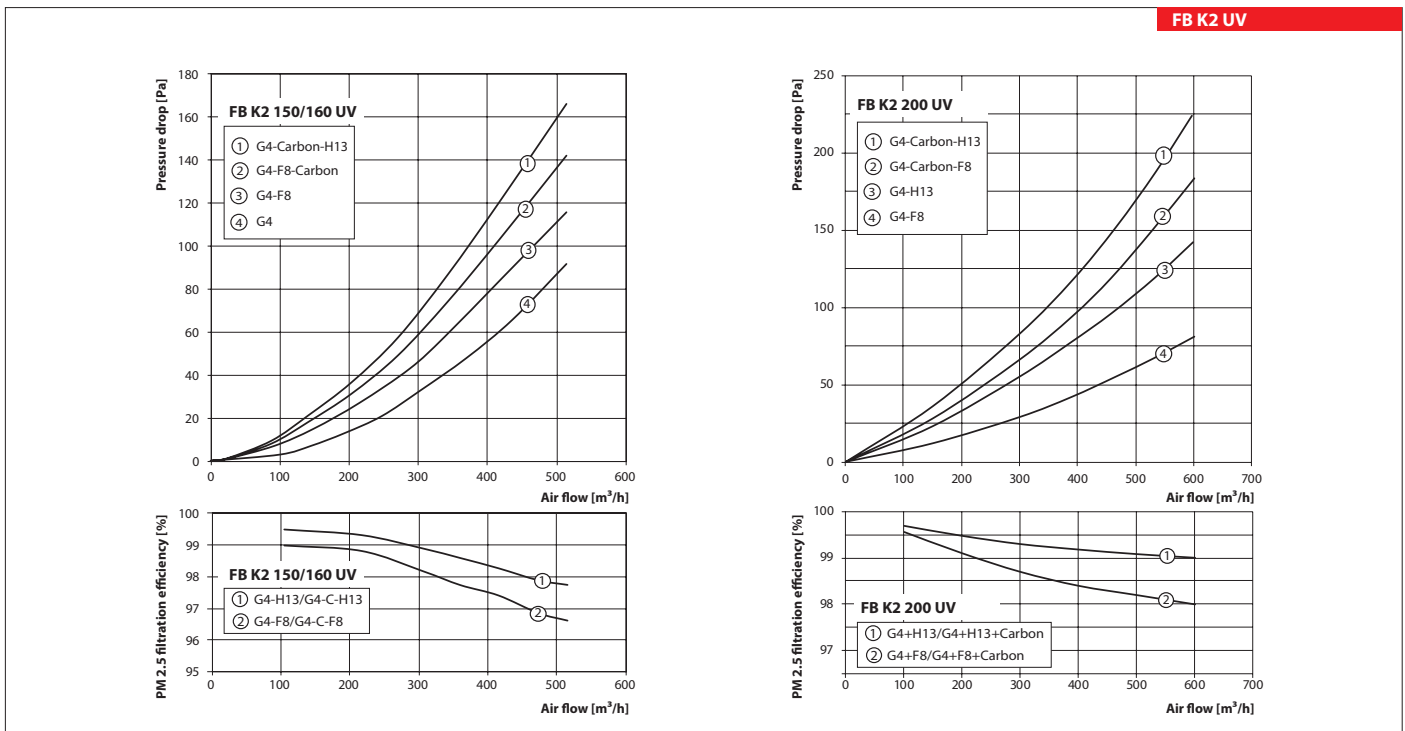

Accessories

Model	G4 replaceable panel filter	F8 replaceable panel filter	H13 replaceable panel filter	Replaceable carbon panel filter
FB K2 150/160	SF 270x425x47-G4	SF 270x425x47-F8	SF 270x425x47-H13	SF 270x425x47-C
FB K2 200	SF 270x590x47-G4	SF 270x590x47-F8	SF 270x590x47-H13	SF 270x590x47-C

KSB, KSB EC, KSB K2, KSF K2 EC,
KSF K2 EC, KSV

FB K2
FB K2 ES
FB K2 UV

A 150 VRF disk valve

Ventilation hood MV 150 VK

MV 150 bVs

Flexivent
semi-rigid duct system

PANEL FILTERS

FB K2 UV

