

USER'S MANUAL

HBF

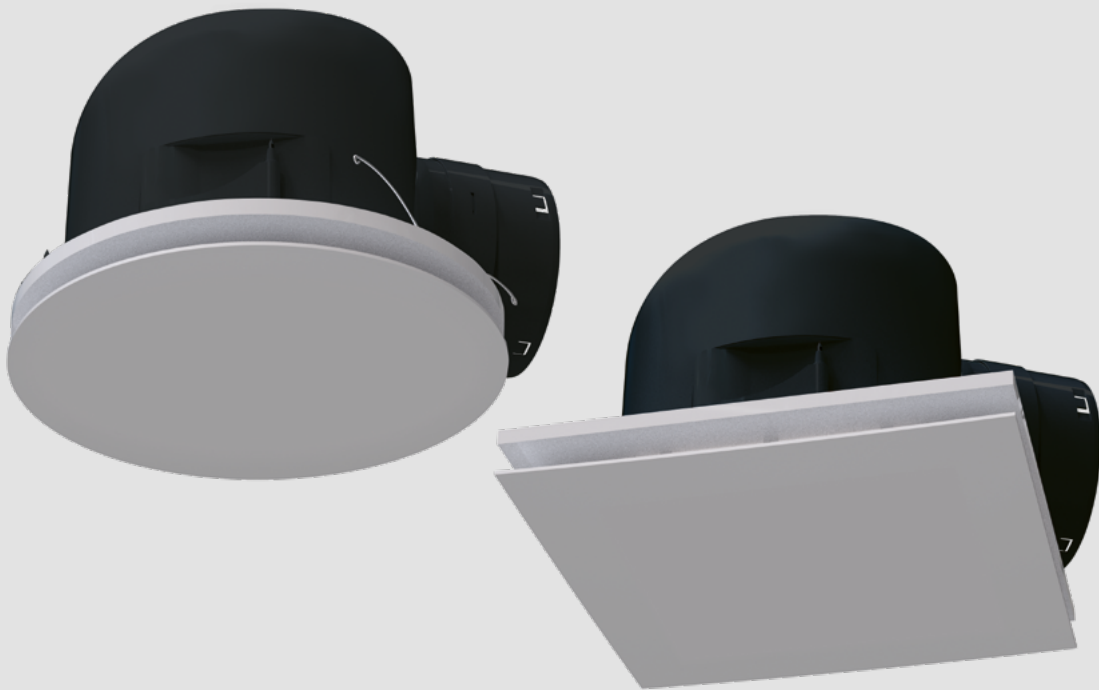

Centrifugal ceiling extract fan

CONTENTS

Safety requirements.....	3
Purpose.....	5
Delivery set.....	5
Designation key.....	5
Technical data.....	6
Design and functioning	7
Mounting and set-up.....	8
Connection to power mains	10
Electronics operation algorithm	11
Technical maintenance.....	12
Storage and transportation regulations.....	12
Manufacturer's warranty	13
Certificate of acceptance.....	15
Seller information	15
Installation certificate.....	15
Warranty card.....	15

This user's manual is a main operating document intended for technical, maintenance, and operating staff.

The manual contains information about purpose, technical details, operating principle, design, and installation of the HBF unit and all its modifications.

Technical and maintenance staff must have theoretical and practical training in the field of ventilation systems and should be able to work in accordance with workplace safety rules as well as construction norms and standards applicable in the territory of the country.

SAFETY REQUIREMENTS

This unit is not intended for use by persons (including children) with reduced physical, sensory or mental capabilities, or lack of experience and knowledge, unless they have been given supervision or instruction concerning use of the unit by a person responsible for their safety. Children should be supervised to ensure that they do not play with the unit.

This appliance can be used by children aged from 8 years and above and persons with reduced physical, sensory or mental capabilities or lack of experience and knowledge if they have been given supervision or instruction concerning use of the appliance in a safe way and understand the hazards involved.

Cleaning and user maintenance shall not be done by children without supervision.

Children shall not play with the appliance.

The maximum altitude of use is 3500 m.

This appliance incorporates an earth connection for functional purposes.

Connection to the mains must be made through a disconnecting device, which is integrated into the fixed wiring system in accordance with the wiring rules for design of electrical units, and has a contact separation in all poles that allows for full disconnection under overvoltage category III conditions.

If the supply cord is damaged, it must be replaced by the manufacturer, its service agent, or similarly qualified persons in order to avoid a safety hazard.

CAUTION: In order to avoid a safety hazard due to inadvertent resetting of the thermal cut-out, this unit must not be supplied through an external switching device, such as a timer, or connected to a circuit that is regularly switched on and off by the utility.

Ensure that the unit is switched off from the supply mains before removing the guard.

WARNING: If there are any unusual oscillating movements, immediately stop using the unit and contact the manufacturer, its service agent or suitably qualified persons.

The replacement of parts of the safety suspension system device shall be performed by the manufacturer, its service agent or suitably qualified persons.

Precautions must be taken to avoid the back-flow of gases into the room from the open flue of gas or other fuel-burning appliances.

The appliance may adversely affect the safe operation of appliances burning gas or other fuels (including those in other rooms) due to back flow of combustion gases. These gases can potentially result in carbon monoxide poisoning. After installation of the unit the operation of flued gas appliances should be tested by a competent person to ensure that back flow of combustion gases does not occur.

Fixing means for attachment to the ceiling such as hooks or other devices shall be fixed with a sufficient strength to withstand 4 times the weight of the appliance.

The mounting of the suspension system shall be performed by the manufacturer, its service agent or suitably qualified persons.

The appliance is to be installed so that the blades are more than 2.3m (2,1 m AU) above the floor.

All operations described in this manual must be performed by qualified personnel only, properly trained and qualified to install, make electrical connections and maintain ventilation units.

Do not attempt to install the product, connect it to the mains, or perform maintenance yourself. This is unsafe and impossible without special knowledge.

Disconnect the power supply prior to any operations with the unit.

All user's manual requirements as well as the provisions of all the applicable local and national construction, electrical, and technical norms and standards must be observed when installing and operating the unit.

Disconnect the unit from the power supply prior to any connection, servicing, maintenance, and repair operations.

Connection of the unit to power mains is allowed by a qualified electrician with a work permit for the electric units up to 1000 V after careful reading of the present user's manual.

Check the unit for any visible damage of the impeller, the casing, and the grille before starting installation. The casing internals must be free of any foreign objects that can damage the impeller blades.

While mounting the unit, avoid compression of the casing! Deformation of the casing may result in motor jam and excessive noise.

Misuse of the unit and any unauthorised modifications are not allowed.

Do not expose the unit to adverse atmospheric agents (rain, sun, etc.).

Transported air must not contain any dust or other solid impurities, sticky substances, or fibrous materials.

Do not use the unit in a hazardous or explosive environment containing spirits, gasoline, insecticides, etc.

Do not close or block the intake or extract vents in order to ensure the efficient air flow.

Do not sit on the unit and do not put objects on it.

The information in this user's manual was correct at the time of the document's preparation.

The Company reserves the right to modify the technical characteristics, design, or configuration of its products at any time in order to incorporate the latest technological developments.

Never touch the unit with wet or damp hands.

Never touch the unit when barefoot.

BEFORE INSTALLING ADDITIONAL EXTERNAL DEVICES, READ THE RELEVANT USER MANUALS.

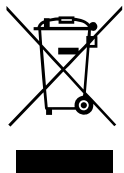

THE PRODUCT MUST BE DISPOSED SEPARATELY AT THE END OF ITS SERVICE LIFE.

DO NOT DISPOSE THE UNIT AS UNSORTED DOMESTIC WASTE.

PURPOSE

The centrifugal ceiling extract fan HBF is designed for extract ventilation of small to medium-sized premises. The unit is rated for continuous operation.



THE UNIT MUST NOT BE OPERATED IN KITCHEN PREMISES.

Transported air must not contain any flammable or explosive mixtures, evaporation of chemicals, sticky substances, fibrous materials, coarse dust, soot and oil particles or environments favourable for the formation of hazardous substances (toxic substances, dust, pathogenic germs).

DELIVERY SET

NAME	HBF 250	HBF 250 Round/Square
Centrifugal ceiling extract fan	1 pc.	1 pc.
Decorative grille	—	1 pc.
User's manual	1 pc.	1 pc.
Packing box	1 pc.	1 pc.

For a fan without a decorative panel, you need to purchase a decorative panel designed for that type of fan. Operation without a decorative panel is prohibited.

DESIGNATION KEY

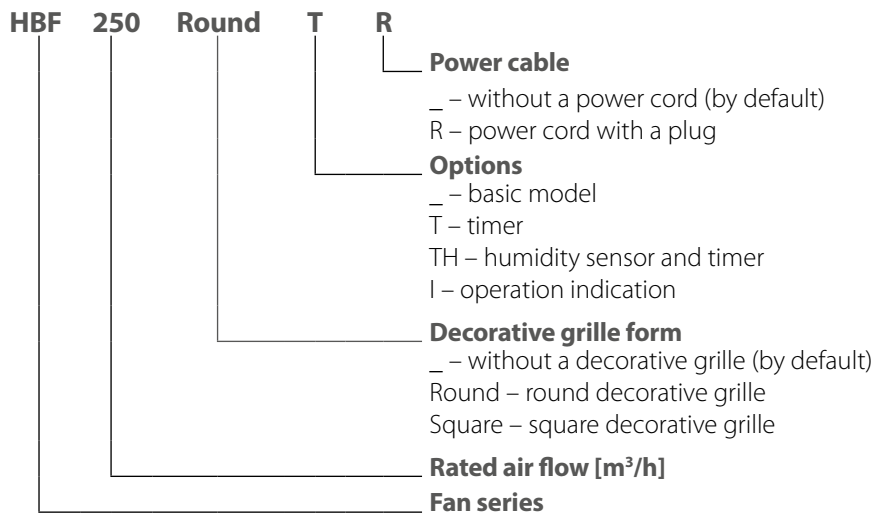

TECHNICAL DATA

The centrifugal ceiling extract fan is designed for indoor application with the ambient temperature ranging from +1 °C up to +40 °C. The unit is rated as a Class I electrical appliance.

Ingress protection rating against access to hazardous parts and water ingress is IPX4.

The unit design is constantly being improved, thus some models may be slightly different from those described in this manual.

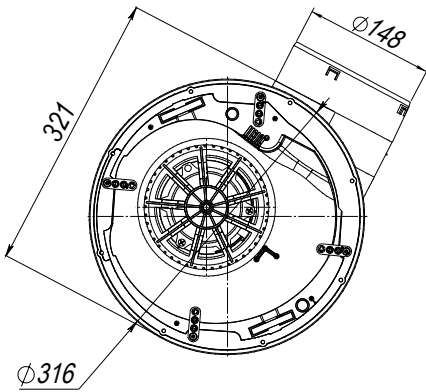
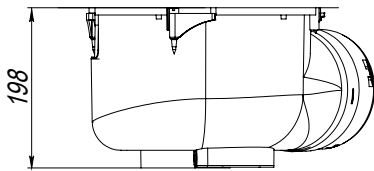
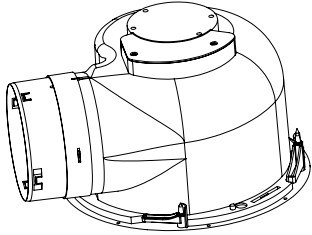
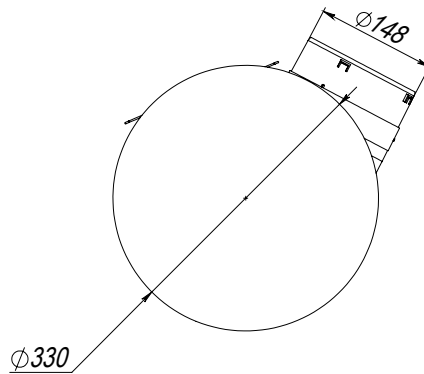
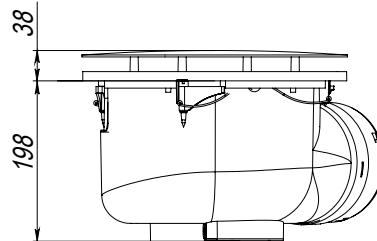
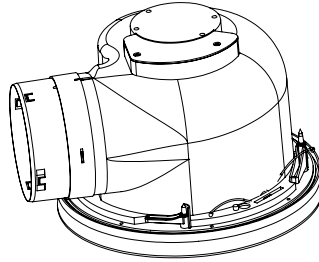
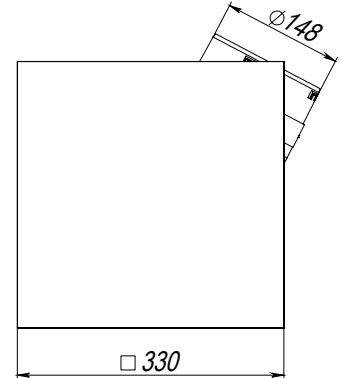
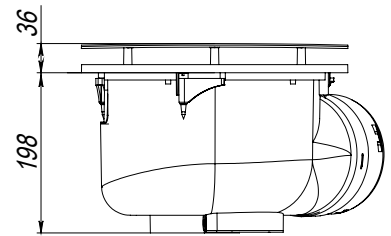
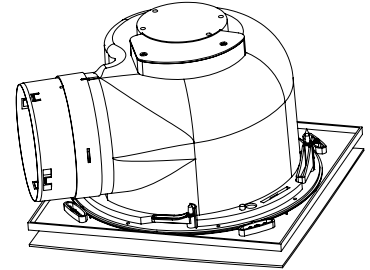
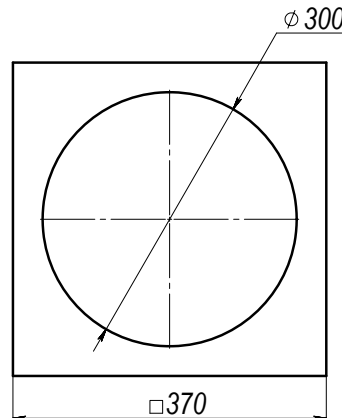
OVERALL AND CONNECTING DIMENSIONS
HBF

HBF ROUND

HBF SQUARE

TEMPLATE FOR MARKING THE FAN INSTALLATION LOCATION

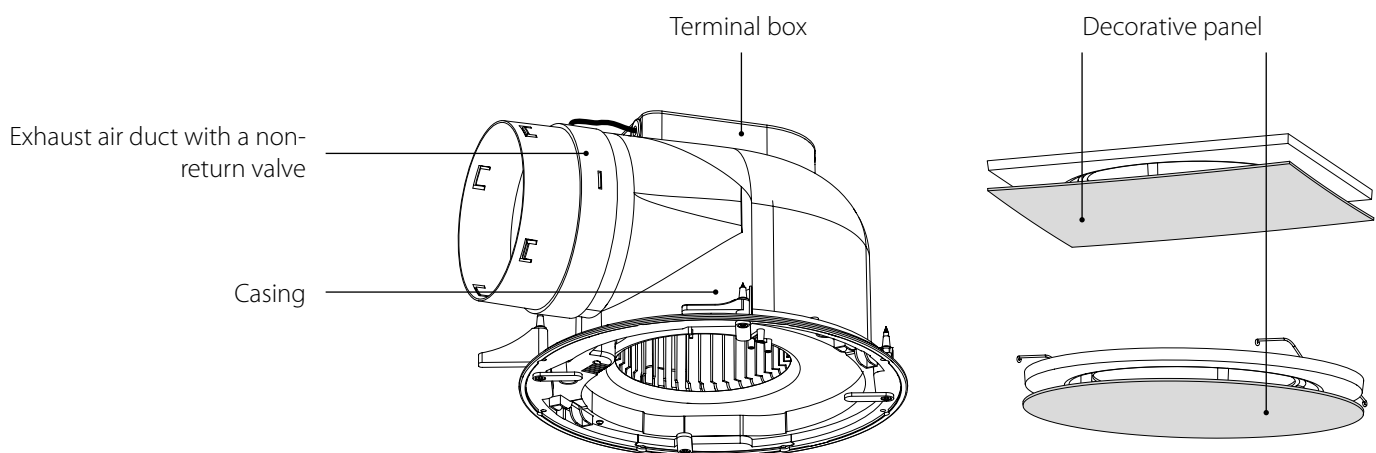
TECHNICAL DATA

PARAMETER	HBF 250	
	Frequency [Hz]	50
Voltage [V]	220-240	220
Rated fan power [W]	57	63
RPM [min ⁻¹]	1085	1085
Current [A]	0.25	0,28
Max. air flow [m ³ /h]	482	482
Max. air flow [l/s]	134	134
Specific fan power (SFP) [W/l/s]	0.43	0,43
Sound pressure level at 3 m distance [dBA]	36	36
Weight [kg]	4.13	4,13
IP	X4	X4
SEC class	C	C

DESIGN AND OPERATING PRINCIPLE



The fan casing is made of plastic.

The extract spigot with a non-return valve is attached to the fan to prevent back air flow.

In the upper part of the casing there is a terminal box, which contains terminals for connecting the fan to power mains and to electronics board, if available.

A single-phase electric motor with a centrifugal impeller with forward curved blades is fastened inside of the casing.

Depending on the model, the fan is equipped with a timer and a humidity sensor.

MOUNTING AND SET-UP**READ THE USER'S MANUAL BEFORE INSTALLING THE UNIT**

The fan is a component part and is not designed for stand-alone operation.

The fan is designed for ceiling mounting and installation in the floor slab with fastening to the ceiling surface using removable rotary clamping brackets on the fan casing.

The fan installation location must comply with local building codes for this type of product.

Check the fan for mechanical damages prior to mounting.

Before mounting make sure the casing does not contain any foreign objects (e.g. foil, paper).

While installing the unit ensure convenient access for subsequent maintenance and repair.

The minimum distance between the fan and the ceiling should be at least 200 mm.

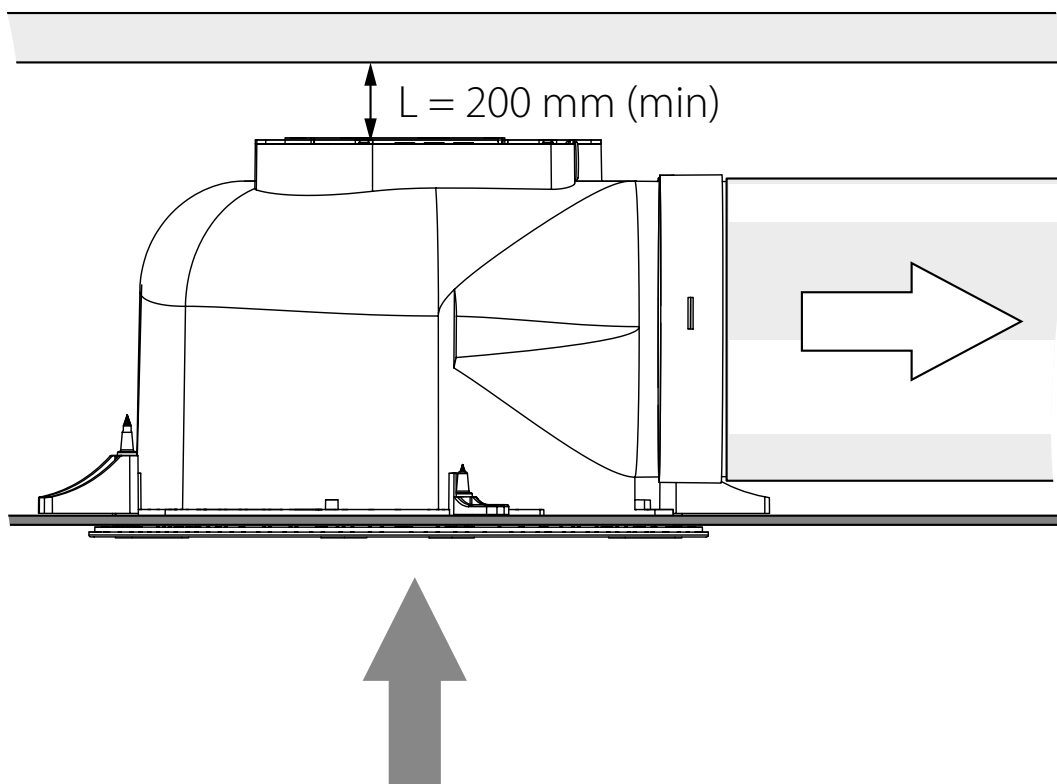

MOUNTING SEQUENCE

1. Use the template to mark the mounting location for the fan and make a hole in the ceiling $\varnothing 300$ mm.

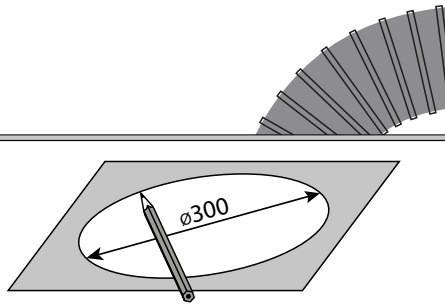

2. The flexible air duct is pushed through the hole from behind the ceiling, from above. The air duct is installed on a spigot with a non-return valve.

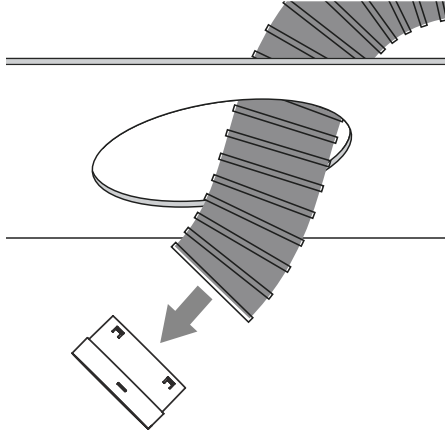

3. Before installation, it is required to loosen the self-tapping screws on the rocking levers, thereby increasing the gap between the casing and the lever.

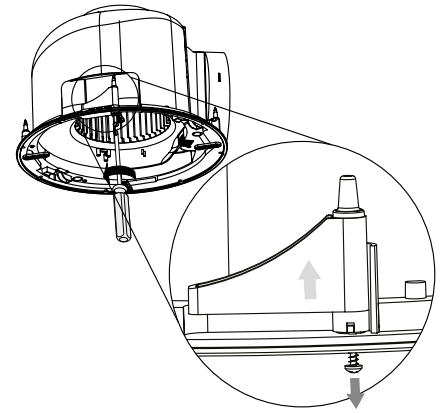

4. The spigot and the air duct are installed on the fan.

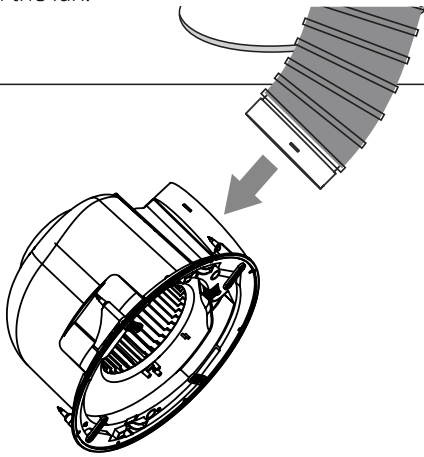

5. The fan assembly is inserted into the ceiling opening from the room side.

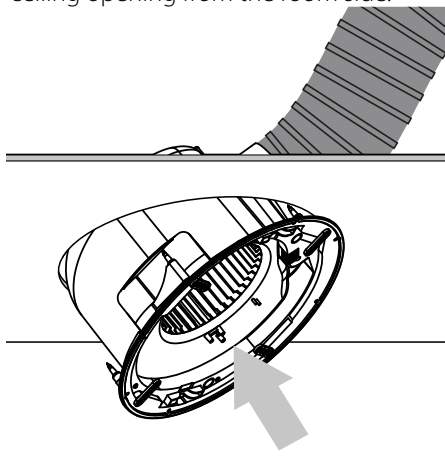

6. Secure the fan by turning the levers.

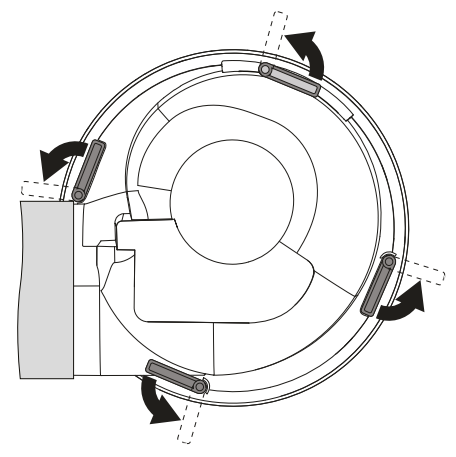

7. After installing the fan, it is necessary to clamp the self-tapping screws on the rocking levers to press the fan casing against the ceiling.

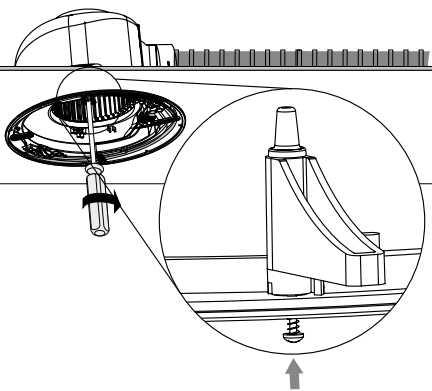

8. Install the decorative panel (purchased separately for the HBF model) on the fan casing. The panel is mounted in accordance with the User's manual for the decorative panel.

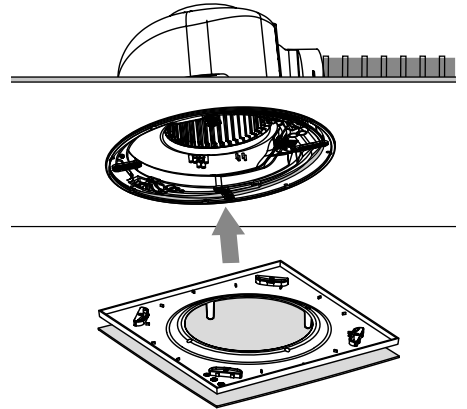
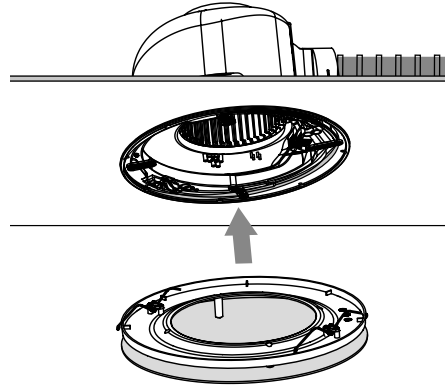

CONNECTION TO POWER MAINS



**POWER OFF THE POWER SUPPLY PRIOR TO ANY OPERATIONS WITH THE UNIT.
THE UNIT MUST BE CONNECTED TO POWER SUPPLY BY A QUALIFIED ELECTRICIAN.
THE RATED ELECTRICAL PARAMETERS OF THE UNIT ARE GIVEN ON THE
MANUFACTURER'S LABEL.**



**ANY TAMPERING WITH THE INTERNAL CONNECTIONS IS PROHIBITED
AND WILL VOID THE WARRANTY.**

The unit is designed for connection to power mains with the parameters specified in the «Technical data» section. The fan is connected to power mains with an electric plug through a QF circuit breaker with a magnetic trip integrated into the fixed wiring system.

The position of the automatic circuit breaker must ensure free access for quick power-off of the unit.

WIRING DIAGRAM OF THE FAN

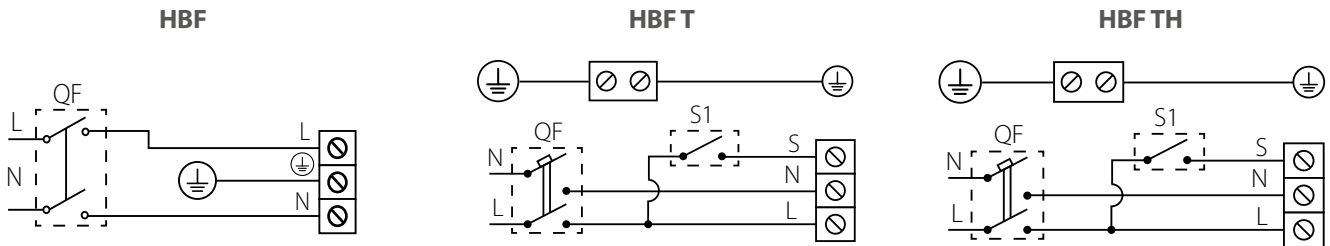

TERMINAL DESIGNATIONS ON THE WIRING DIAGRAM: L – phase; N – neutral; S1 — switch; QF – automatic circuit breaker.

ELECTRONICS OPERATION ALGORITHM

Timer (T)

After turning on an external switch, such as a light switch, the fan turns on.

After the switch is turned off the fan keeps operating for a set turn-off delay time period, adjustable from 2 to 30 minutes.

Humidity sensor (TH)

If the set humidity level in the room is exceeded from 60 % to 90 %, the fan turns on.

As the indoor humidity level drops down the fan keeps operating for a set turn-off delay time period, adjustable from 2 to 30 minutes, and then turns off.

The fan delivery set includes a specially designed plastic screwdriver for fan settings adjustments. Use it to change the turn-on and turn-off delay time and the humidity set point.

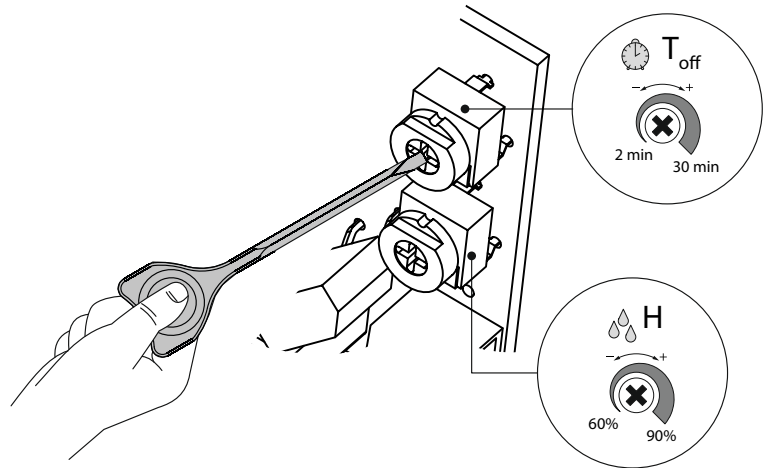

 **T_{on}** — To adjust the fan turn-on delay time, turn the control knob **T_{on}** clockwise to increase and counter-clockwise to decrease the turn-on delay time respectively, adjustable from 2 up to 30 minutes.

 **H** — To adjust the humidity set point, turn the control knob **H** clockwise to increase and counter-clockwise to decrease the humidity sensor set point, adjustable from 60 % up to 90 %.



**DO NOT USE A METAL SCREWDRIVER, KNIFE, ETC. FOR ADJUSTMENT
OPERATIONS NOT TO DAMAGE THE CIRCUIT BOARD**

TECHNICAL MAINTENANCE



DISCONNECT THE UNIT FROM POWER SUPPLY BEFORE ANY MAINTENANCE OPERATIONS!
MAKE SURE THE UNIT IS DISCONNECTED FROM POWER MAINS BEFORE REMOVING THE PROTECTION.

The technical maintenance includes periodic cleaning of the surfaces from accumulated dust and dirt when the fan is disconnected from power supply. The impeller cleaning procedure is shown below. The impeller blades require thorough cleaning from dust and dirt once in 6 months.

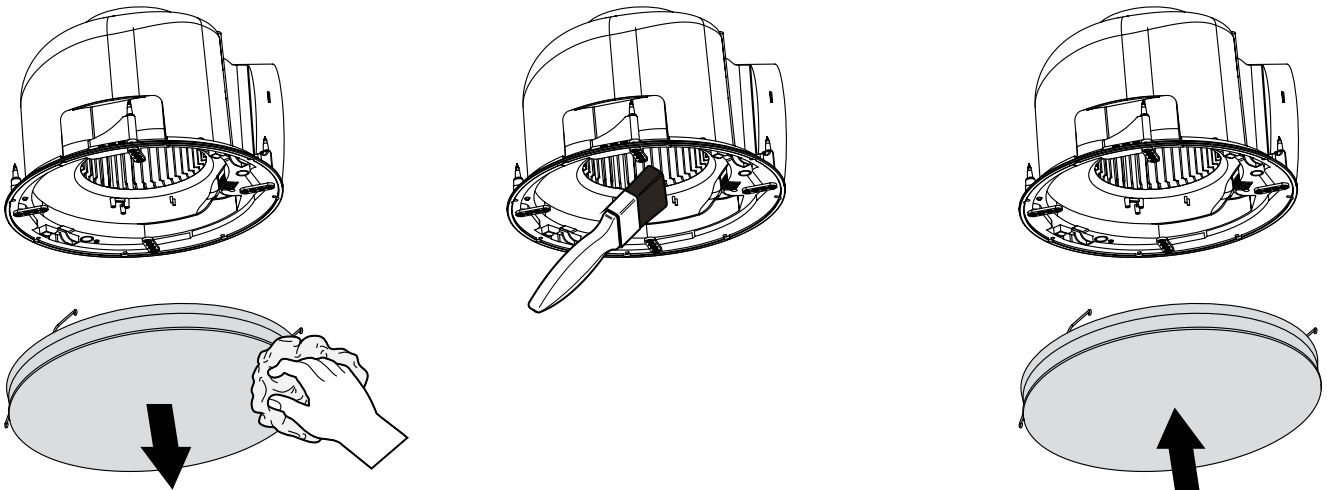

TROUBLES AND TROUBLESHOOTING

TROUBLE	POSSIBLE REASONS	TROUBLESHOOTING
The fan does not get started.	No power supply.	Check the electric connections and the operation status of the circuit breaker.
	Motor jam.	Turn the fan off. Troubleshoot clogging of the impeller. Restart the fan.
Automatic circuit breaker tripping during the unit turning on.	Overcurrent as a result of short circuit in the electric circuit leads to tripping of the circuit breaker.	Disconnect the fan from power supply and contact the product Seller. Do not turn the fan on again!
Low air flow.	Air ducts or other components of the ventilation system are clogged. The impeller is clogged. The air ducts are damaged. The air dampers are closed.	Clean the air ducts, the impeller and other components of the ventilation system. Make sure that the air ducts are not damaged. Make sure that the air dampers and louvre shutters are open.

STORAGE AND TRANSPORTATION REGULATIONS

- Store the unit in the manufacturer's original packaging box in a dry closed ventilated premise with temperature range from +5 °C to +40 °C and relative humidity up to 70 %.
- Storage environment must not contain aggressive vapors and chemical mixtures provoking corrosion, insulation, and sealing deformation.
- Use suitable hoist machinery for handling and storage operations to prevent possible damage to the unit.
- Follow the handling requirements applicable for the particular type of cargo.
- The unit can be carried in the original packaging by any mode of transport provided proper protection against precipitation and mechanical damage. The unit must be transported only in the working position.
- Avoid sharp blows, scratches, or rough handling during loading and unloading.
- Prior to the initial power-up after transportation at low temperatures, allow the unit to warm up at operating temperature for at least 3-4 hours.

MANUFACTURER'S WARRANTY

The product is in compliance with EU norms and standards on low voltage guidelines and electromagnetic compatibility. We hereby declare that the product complies with the provisions of Electromagnetic Compatibility (EMC) Directive 2014/30/EU of the European Parliament and of the Council, Low Voltage Directive (LVD) 2014/35/EU of the European Parliament and of the Council and CE-marking Council Directive 93/68/EEC. This certificate is issued following test carried out on samples of the product referred to above.

The manufacturer hereby warrants normal operation of the unit for 24 months after the retail sale date provided the user's observance of the transportation, storage, installation, and operation regulations. Should any malfunctions occur in the course of the unit operation through the Manufacturer's fault during the guaranteed period of operation, the user is entitled to get all the faults eliminated by the manufacturer by means of warranty repair at the factory free of charge. The warranty repair includes work specific to elimination of faults in the unit operation to ensure its intended use by the user within the guaranteed period of operation. The faults are eliminated by means of replacement or repair of the unit components or a specific part of such unit component.

The warranty repair does not include:

- routine technical maintenance
- unit installation/dismantling
- unit setup

To benefit from warranty repair, the user must provide the unit, the user's manual with the purchase date stamp, and the payment paperwork certifying the purchase. The unit model must comply with the one stated in the user's manual. Contact the Seller for warranty service.

The manufacturer's warranty does not apply to the following cases:

- User's failure to submit the unit with the entire delivery package as stated in the user's manual including submission with missing component parts previously dismantled by the user.
- Mismatch of the unit model and the brand name with the information stated on the unit packaging and in the user's manual.
- User's failure to ensure timely technical maintenance of the unit.
- External damage to the unit casing (excluding external modifications as required for installation) and internal components caused by the user.
- Redesign or engineering changes to the unit.
- Replacement and use of any assemblies, parts and components not approved by the manufacturer.
- Unit misuse.
- Violation of the unit installation regulations by the user.
- Violation of the unit control regulations by the user.
- Unit connection to power mains with a voltage different from the one stated in the user's manual.
- Unit breakdown due to voltage surges in power mains.
- Discretionary repair of the unit by the user.
- Unit repair by any persons without the manufacturer's authorization.
- Expiration of the unit warranty period.
- Violation of the unit transportation regulations by the user.
- Violation of the unit storage regulations by the user.
- Wrongful actions against the unit committed by third parties.
- Unit breakdown due to circumstances of insuperable force (fire, flood, earthquake, war, hostilities of any kind, blockades).
- Missing seals if provided by the user's manual.
- Failure to submit the user's manual with the unit purchase date stamp.
- Missing payment paperwork certifying the unit purchase.



FOLLOWING THE REGULATIONS STIPULATED HEREIN WILL ENSURE A LONG AND TROUBLE-FREE OPERATION OF THE UNIT



USER'S WARRANTY CLAIMS SHALL BE SUBJECT TO REVIEW ONLY UPON PRESENTATION OF THE UNIT, THE PAYMENT DOCUMENT AND THE USER'S MANUAL WITH THE PURCHASE DATE STAMP

CERTIFICATE OF ACCEPTANCE

Unit Type	Centrifugal ceiling extract fan
Model	
Serial Number	
Manufacture Date	
Quality Inspector's Stamp	

SELLER INFORMATION

Seller	
Address	
Phone Number	
E-mail	
Purchase Date	
This is to certify acceptance of the complete unit delivery with the user's manual. The warranty terms are acknowledged and accepted.	
Customer's Signature	

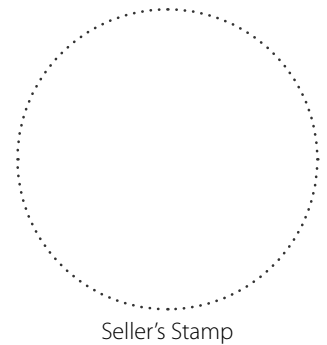

INSTALLATION CERTIFICATE

The _____ unit is installed pursuant to the requirements stated in the present user's manual.	
Company name	
Address	
Phone Number	
Installation Technician's Full Name	
Installation Date:	Signature:
The unit has been installed in accordance with the provisions of all the applicable local and national construction, electrical and technical codes and standards. The unit operates normally as intended by the manufacturer.	
Signature:	

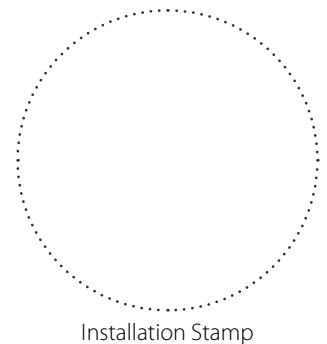

WARRANTY CARD

Unit Type	Centrifugal ceiling extract fan
Model	
Serial Number	
Manufacture Date	
Purchase Date	
Warranty Period	
Seller	

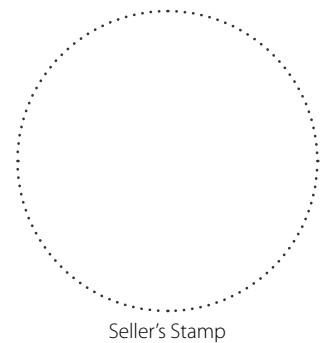

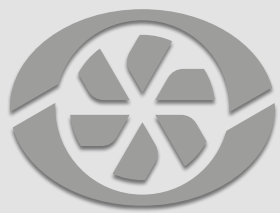

VENTS

