

**AIR DAMPERS**

**Series  
KRV**



**Application**

Air damper for air flow cut-off in round air ducts. Compatible with duct sizes: Ø 80, 100, 125, 150, 160, 200, 250, 315, 355, 400, 450, 500, 550 and 630 mm.

**Design**

The housing and the blade made of galvanized steel. Connecting spigots with rubber sealing gaskets. Universal shaft for automatic actuator (available upon

separate order). Compatible actuators are shown in the table below.

**Mounting**

The damper is connected to round air duct and fixed with clamps.

**Compatible Belimo actuators**

Model	Actuator drive			
	Electric actuator, 230 V	Electric actuator with spring return, 230 V	Electric actuator, 24 V	Electric actuator with spring return, 24 V
KRV 80	CM230/LM230A	TF230	CM24 / LM24A	TF24
KRV 100			CM24 / LM24A	TF24
KRV 125	CM230/LM230A	TF230	CM24 / LM24A	TF24
KRV 150			CM24 / LM24A	TF24
KRV 160	CM230/LM230A	TF230	CM24 / LM24A	TF24
KRV 200			CM24 / LM24A	TF24
KRV 250	CM230/LM230A	TF230	CM24 / LM24A	TF24
KRV 315			CM24 / LM24A	TF24
KRV 355	CM230/LM230A	TF230	CM24 / LM24A	TF24
KRV 400			CM24 / LM24A	TF24
KRV 450	CM230/LM230A	TF230	CM24 / LM24A	TF24
KRV 500			CM24 / LM24A	TF24
KRV 550	CM230/LM230A	TF230	CM24 / LM24A	TF24
KRV 630			CM24 / LM24A	TF24

**Overall dimensions**

Type	Dimensions [mm]				Mass [kg]
	ØD	B	L	H	
KRV 80	79	190	200	170	0.6
KRV 100	99	220	200	180	0.72
KRV 125	124	245	200	195	0.86
KRV 150	149	270	200	205	1.01
KRV 160	159	280	200	210	1.07
KRV 200	199	320	200	230	1.33
KRV 250	249	370	200	255	1.68
KRV 315	314	435	240	-	2.44
KRV 355	348	475	240	-	2.75
KRV 400	399	520	240	-	3.26
KRV 450	449	570	240	-	3.78
KRV 500	499	620	240	-	5.55
KRV 550	549	670	240	-	6.27
KRV 630	629	750	240	-	7.49

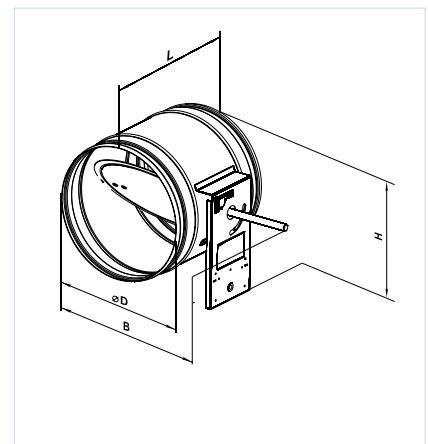
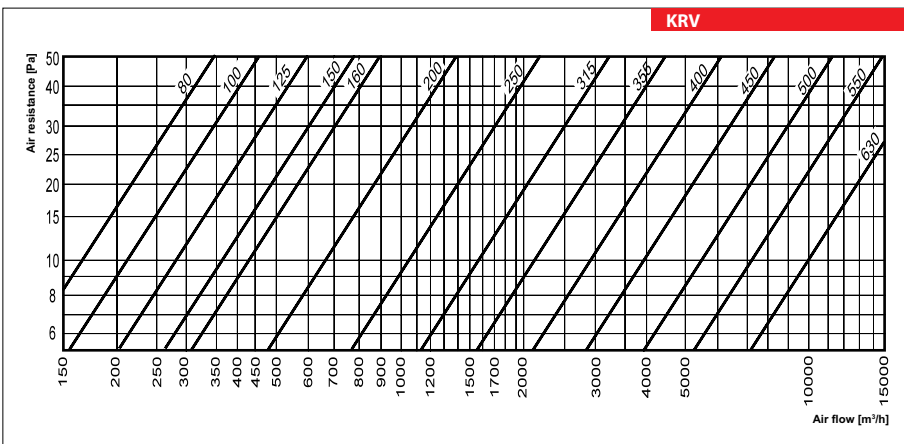

**Designation key**

Series	Spigot diameter [mm]
KRV	80; 100; 125; 150; 160; 200; 250; 315; 355; 400; 450; 500; 550; 630

**Accessories**

