



ECO-VENTILATION

Fresh air in your house!



Single-room air handling units with heat recovery

Micra

Wi-Fi
Energy saving
Compact size

Multi-purpose functioning
Easy mounting
Silent operation



Micra 200 ERV WiFi



FEATURES

- Efficient solution for supply and exhaust ventilation of enclosed spaces.
- Modifications with an electric preheater and/or reheater are available for cold climate conditions.
- EC motors with low energy demand.
- Supply air purification up to 99 % PM 2.5 ensured by two built-in G4 and F8 filters. Additional air purification due to recirculation. An H13 filter is optionally available.
- Upgradeable with an exhaust duct to provide air extraction from the bathroom.
- Easy installation.
- Compact size.
- Modern design.
- Control via Android/iOS mobile application.

DESIGN

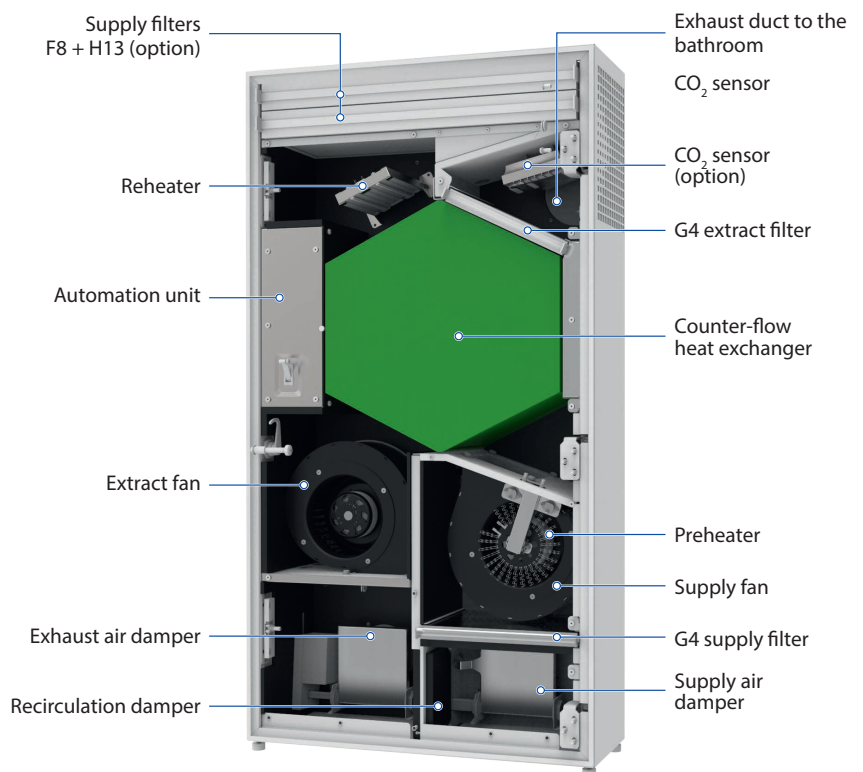

Air flow up to **200 m³/h.**

Micra 200 ERV WiFi is a single-room energy-efficient supply and exhaust unit intended for decentralised ventilation of residential and commercial spaces as well as apartments and houses.

Micra 200 ERV WiFi is ideally suited for creating simple and efficient ventilation in new and reconstructed buildings. The unit does not require installation of a duct system.

CASING

The casing is made of polymer coated metal. Due to modern design, the unit can seamlessly blend with most any interior design. The front panel provides convenient access for filter maintenance and has a lock for extra security. The unit has two ø 100 mm pipes for fresh air intake and stale air extraction outside. The third ø 100 mm pipe (included in the delivery set) can be additionally fitted to the unit to connect the exhaust air duct from the bathroom.

AIR DAMPERS

The unit is equipped with supply and exhaust air dampers which activate automatically to prevent drafts while the unit is off.

RECIRCULATION

The supply and exhaust air dampers close when the air purification function is turned on. The recirculation damper opens. The room air circulates through the filters. Then it is returned purified back to the room.

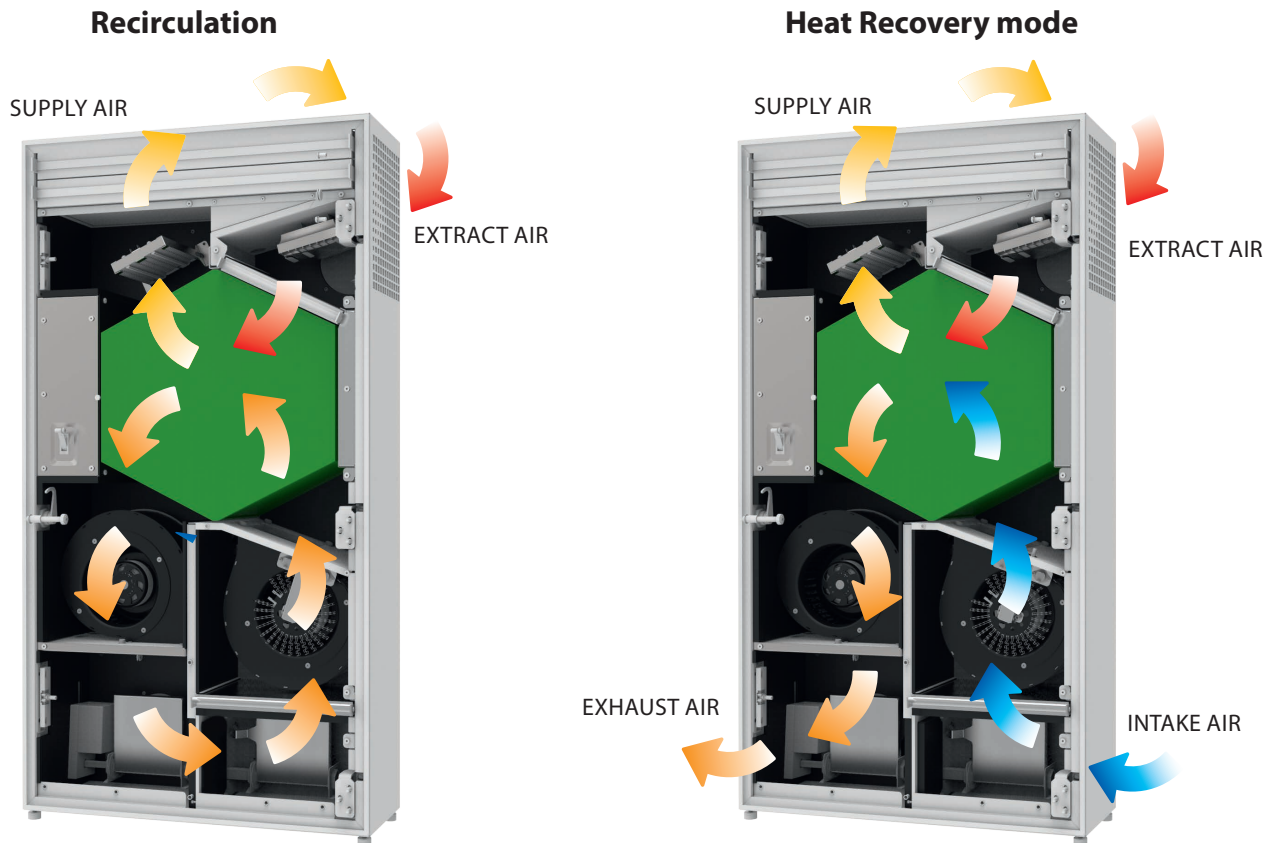

AIR FILTRATION

Supply and recirculation air cleaning is provided by G4 and F8 panel filters (PM 2.5 > 75%). To meet more stringent air purity requirements, an H13 filter (PM 2.5 > 99%) (purchased separately) can be installed in addition to an F8 filter. Extract air is cleaned by a panel G4 filter.

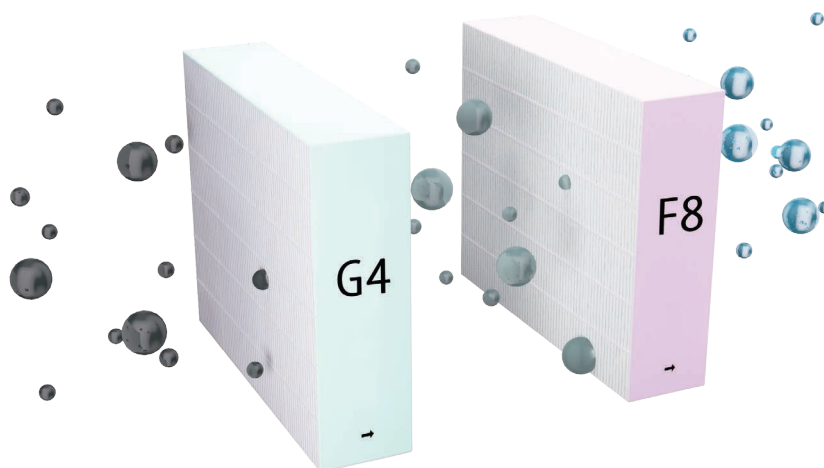

MOTOR

The units feature efficient electronically commutated (EC) motors with an external rotor and impellers with forward curved blades. These state-of-the-art motors are the most advanced solution in energy efficiency today. In addition to that, the efficiency of electronically commutated motors reaches very impressive levels of up to 90 %. EC motors are characterised with high performance and optimum control across the entire speed range.

PREHEATING

The Micra 200 E ERV WiFi and Micra 200 E2 ERV WiFi units are equipped with an electric preheater which protects the heat exchanger from freezing.

REHEATING

The Micra 200 E1 ERV WiFi and Micra 200 E2 ERV WiFi units feature an electric reheater to raise the supply air temperature as necessary.

HEAT EXCHANGER

The Micra 200 ERV WiFi units are equipped with a counter-flow heat exchanger with an enthalpy membrane. In the cold season the extract air heat and moisture are transferred to the supply air stream through the enthalpy membrane reducing the heat losses from ventilation.

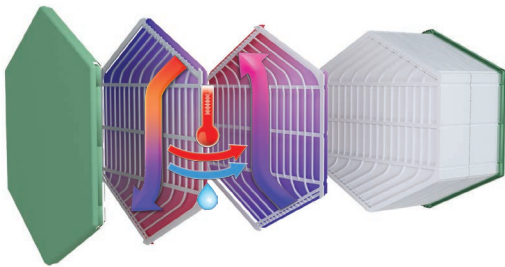

The ambient air heat and moisture are transferred to the exhaust air stream through the enthalpy membrane in the warm season. This allows for a considerable reduction of the supply air temperature and humidity which, in turn, reduces the air conditioning load.

CONTROL

- The units are equipped with a control panel.
- Remote control panels are supplied as standard.
- Wi-Fi connection available.
- Control via a smartphone or a tablet based on Android or IOS.



FOLLOWING FUNCTIONS ARE AVAILABLE:

- Speed switching
- Filter replacement indication
- Alarm indication
- Speed setup
- Timer
- Weekly schedule

FREEZE PROTECTION

The Micra 200 ERV WiFi features an exhaust air temperature sensor downstream of the heat exchanger which disables the supply fan to let the warm extract air warm up the heat exchanger. Then the supply fan is turned on and the unit reverts to normal operation. Overheating protection for Micra 200 E ERV WiFi and Micra 200 E2 ERV WiFi is implemented with a preheater.



 Google play

VENTS MICRA app is available
at Google Play market and App Store

 Download on the
App Store

CONTROL PANEL

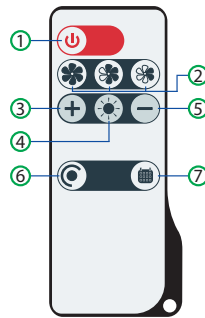
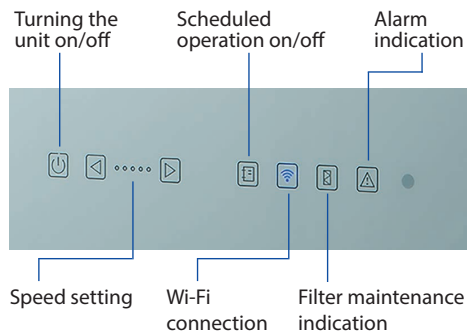

- ① Turning the unit on/off
- ② Speed selection
- ③ Temperature setpoint increase for a reheater (for models equipped with a reheater)
- ④ Switching the reheater on/off (for models equipped with a reheater)
- ⑤ Temperature setpoint decrease for a reheater (for models equipped with a reheater)
- ⑥ Timer on/off
- ⑦ Scheduled operation on/off

Following functions are available:

	Micra 200 ERV WiFi Micra 200 E ERV WiFi	Micra 200 E1 ERV WiFi Micra 200 E2 ERV WiFi
Speed switching	+	+
Filter replacement indication	+	+
Alarm indication	+	+
Speed setting	+	+
Timer	+	+
Weekly schedule	+	+
Reheating enabled/disabled	-	+
Supply air temperature setting	-	+
Control via VENTS MICRA Android/iOS mobile application	+	+

Technical data

ENERG
енергия · ενεργεια
Y IJA
IE IA

VENTS **Micra 200 ERV WiFi**

A+

A

B

C

D

E

F

G

A

39
dB(A)

200
m³/h

ENERGIA · ЕНЕРГИЯ · ΕΝΕΡΓΕΙΑ · ENERGIA · ENERGY · ENERGIE · ENERGI
2018 1254/2014

	Micra 200 ERV WiFi					
	Cold		Average		Warm	
Specific energy consumption (SEC) [kWh/(m ² .a)]	-70.5	A+	-35.9	A	-13.5	E
Type of ventilation unit	Bidirectional					
Type of drive installed	With variable rotation frequency					
Type of heat recovery system	Regenerative					
Thermal efficiency of heat recovery [%]	68					
Maximum air flow [m ³ /h]	200					
Electric power input [W]	125					
Sound power level [dBA]	39					
Reference flow rate [m ³ /s]	0.039					
Reference pressure difference [Pa]	N/A					
Specific power input (SPI) [W/m ³ /h]	0.366					
Control typology	Local demand control					
Maximum internal leakage rates [%]	0.1					
Maximum external leakage rates [%]	0.9					
Mixing rate of bidirectional units [%]	20					
Airflow sensitivity at +20 Pa and -20 Pa	0.93					
The indoor/outdoor air tightness [m ² /h]	7					
Internet address	http://www.ventilation-system.com					
The annual electricity consumption (AEC) [kWh electricity/a]	Cold	Average		Warm		
	795	258		213		
The annual heating saved (AHS) [kWh primary energy/a]	Cold	Average		Warm		
	8161	4172		1886		

VENTS. Single-room air handling units | Micra | 08-2018

SINGLE ROOM ENERGY-SAVING VENTILATION



Technical data

	Micra 200 ERV WiFi					Micra 200 E ERV WiFi					Micra 200 E1 ERV WiFi					Micra 200 E2 ERV WiFi				
Speed	1	2	3	4	5	1	2	3	4	5	1	2	3	4	5	1	2	3	4	5
Unit voltage [V/50 (60) Hz]	1~220-240																			
Maximum unit power without an electric heater [W]	20	37	52	87	125	20	37	52	87	125	20	37	52	87	125	20	37	52	87	125
Electric preheater power [W]	-					650					-					650				
Electric reheater power [W]	-					-					700					700				
Maximum unit current (with a heater) [A]	1.0					4.0					4.2					7.2				
Maximum air flow [m³/h]	30	60	90	120	200	30	60	90	120	200	30	60	90	120	200	30	60	90	120	200
RPM [min ⁻¹]	2000																			
Sound pressure level at 3 m distance [dBA]	12	22	30	36	45	12	22	30	36	45	12	22	30	36	45	12	22	30	36	45
Transported air temperature [°C]	from -15 up to +50																			
Casing material	polymer-coated steel																			
Insulation [mm]	30																			
Extract filter	G4																			
Supply filter	G4 + F8 (H13 optional)																			
Connected air duct diameter [mm]	Ø 100																			
Weight [kg]	55																			
Heat recovery efficiency [%]*	75	70	68	67	66	75	70	68	67	66	75	70	68	67	66	75	70	68	67	66
Heat exchanger type	counter-flow																			
Heat exchanger material	enthalpy membrane																			
SEC class	A																			

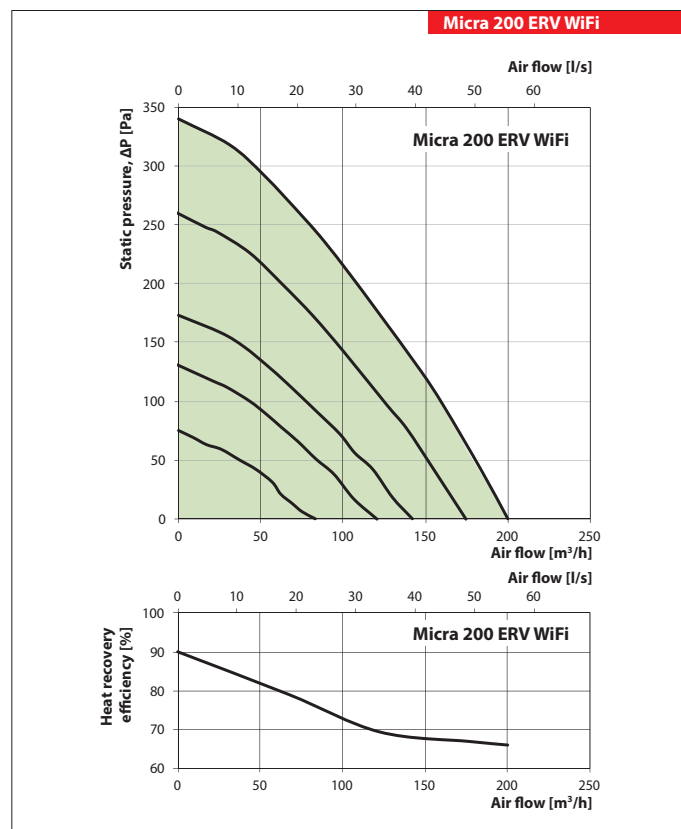
*Heat recovery efficiency is specified in compliance with EN 13141-8



Accessories

Model	Panel filter G4	Panel filter G4	Panel filter F7	Panel filter H13	External CO ₂ sensor with indication	External CO ₂ sensor
Micra 200 ERV WiFi						
Micra 200 E ERV WiFi	SF 201x162x20 G4	SF 243x162x20 G4	SF 502x162x40 F7	SF 502x162x40 H13	CO2-1	CO2-2
Micra 200 E1 ERV WiFi						
Micra 200 E2 ERV WiFi						

OVERALL DIMENSIONS

Model	Dimensions [mm]					
	Ø D	A	B	C	E	F
Micra 200 (E/E1/E2) ERV	100	1018	550	240	265	200

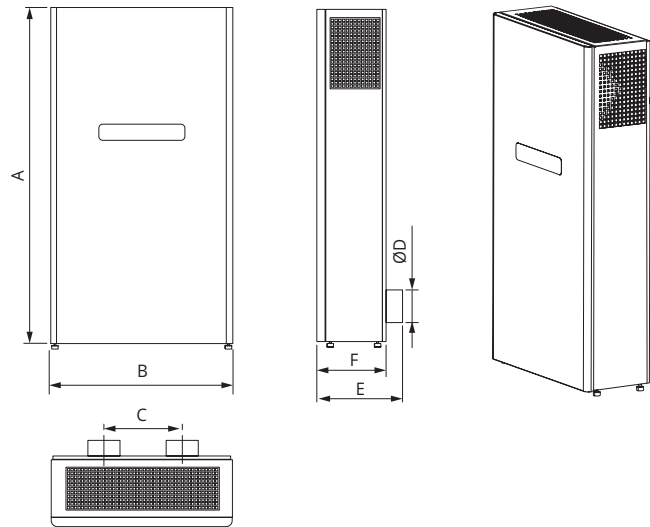

APPLICATION OPTIONS

Each space requiring proper ventilation is equipped with a single or several Micra 200 ERV WiFi units.

Micra 200 ERV WiFi units can be upgraded with a bathroom exhaust air duct.

To enable such a configuration, the units can be additionally equipped with an optional \varnothing 100 mm pipe (included in the delivery set).

Micra 200 ERV WiFi application in an office space

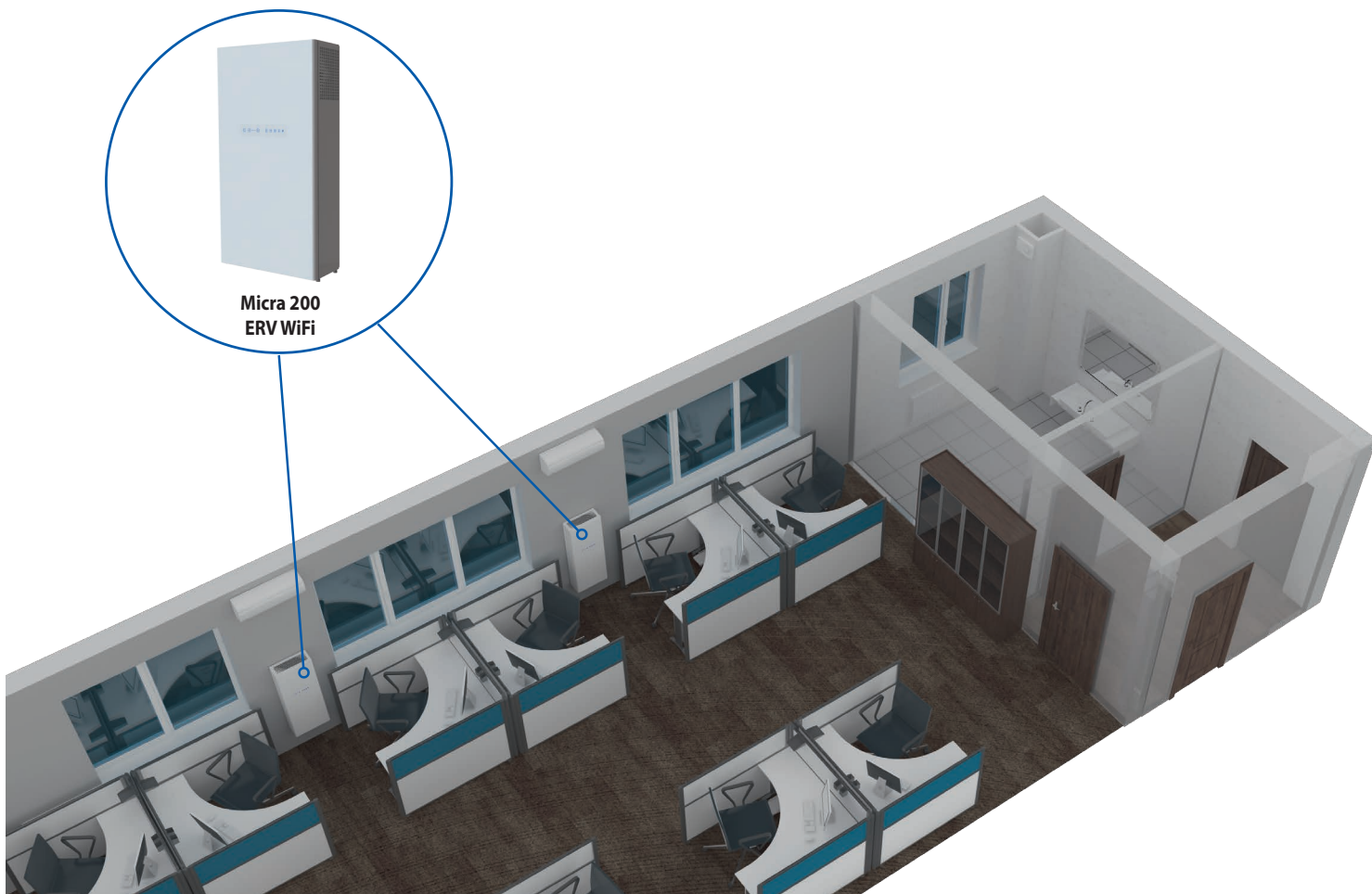



VENTS WORLD VENTILATION LEADER



VENTILATION SYSTEMS
www.ventilation-system.com



**Single-room air handling units
with heat recovery**

VENTS reserves the rights to modify any of its products' features, designs, components and specifications at any time and without notice to maintain the development and quality of manufactured goods.

2022-07



HVI
MEMBER™



vents.ua