

NKD A21 V.2 Series



Duct heater for supply air post-heating with external control

Application

The heater is designed for integration into a ventilation system and joint operation with an air handling unit equipped with a control system used to switch on the heater and control its operation.

The heater maintains the supply duct air temperature at a point set by the unit controller.

Design

The casing, the junction box and the heater cover are made of galvanized steel with the heating elements in stainless steel. The heater casing is additionally heat-insulated with 20 mm non-flammable mineral wool layer. The heaters are equipped with rubber seals for airtight connection to the air ducts.

NKD A21 V.2 duct heaters are equipped with a factory-wired power cable and a control cable, and also have a duct temperature sensor that is connected to the ventilation unit. Temperature control is carried out smoothly by the ventilation

unit controller due to the PWM signal in cycles of 10 seconds. Load commutation is carried out by the semiconductor device (triac).

The heaters are equipped with overheat thermostats:

- ▶ main overheat protection with automatic reset at +50 °C
- ▶ emergency overheat protection with manual reset at +90 °C

Mounting

The heater design ensures its mounting on the round ducts in any position by means of clamps (included in delivery).

The air flow direction shall match the direction of the arrow on the heater casing.

In case of horizontal mounting the control box must be installed with the cover upwards.

Swivel range from the normal position up to max. 90°.

Do not install the control box with the cover downwards.

Overall dimensions of the units

Model	Dimensions [mm]				
	Ø D	B	H	L	L1
NKD 125-0.6-1					
NKD 125-0.8-1	125	164	249	306	192
NKD 125-1.2-1					
NKD 150-0.8-1					
NKD 150-1.2-1	150	189	280	306	192
NKD 150-1.7-1					
NKD 150-2.0-1					
NKD 160-0.8-1					
NKD 160-1.2-1	160	197	291	306	192
NKD 160-1.7-1					
NKD 160-2.0-1					
NKD 200-1.2-1					
NKD 200-1.7-1	200	239	336	306	192
NKD 200-2.0-1					
NKD 250-1.2-1					
NKD 250-2.0-1	250	287	388	307	192
NKD 250-3.0-1					
NKD 315-2.0-1	315	353	454	306	192
NKD 315-3.0-1					

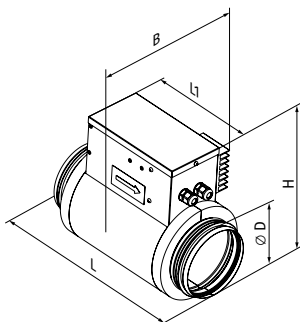

Designation key

Series	Connected air duct diameter [mm]	Heater power [kW]	Phases	Options
NKD	125; 150; 160; 200; 250; 315	0.6; 0.8; 1.2; 1.7; 2.0; 3.0	1: single-phase	A21 V.2: compatible with A21 automation, without a DB-9M connector

Technical data

Model	Min. air flow [m³/h]	Power [kW]	Current [A]
NKD 125-0.6-1	60	0.6	2.6
NKD 125-0.8-1	80	0.8	3.5
NKD 125-1.2-1	90	1.2	5.2
NKD 150-0.8-1	80	0.8	3.5
NKD 150-1.2-1	90	1.2	5.2
NKD 150-1.7-1	160	1.7	7.4
NKD 150-2.0-1	170	2.0	8.7
NKD 160-0.8-1	80	0.8	3.5
NKD 160-1.2-1	150	1.2	5.2
NKD 160-1.7-1	160	1.7	7.4
NKD 160-2.0-1	170	2.0	8.7
NKD 200-1.2-1	150	1.2	5.2
NKD 200-1.7-1	160	1.7	7.4
NKD 200-2.0-1	170	2.0	8.7
NKD 250-1.2-1	180	1.2	5.2
NKD 250-2.0-1	200	2.0	8.7
NKD 250-3.0-1	375	3.0	13.0
NKD 315-2.0-1	220	2.0	8.7
NKD 315-3.0-1	320	3.0	13.0

Compatibility table

Heater model (connected air duct diameter)	Options
NKD 125 A21 V.2	VUT/VUEVB EC A21
NKD 150 A21 V.2	VUT/VUEVB EC A21
NKD 160 A21 V.2	VUT/VUEVB EC A21
NKD 200 A21 V.2	VUT/VUEVB EC A21
NKD 250 A21 V.2	VUT/VUEVB EC A21
NKD 315 A21 V.2	AirVents with a 315 mm spigot and an A21 automation without a DB-9M connector

Technical data

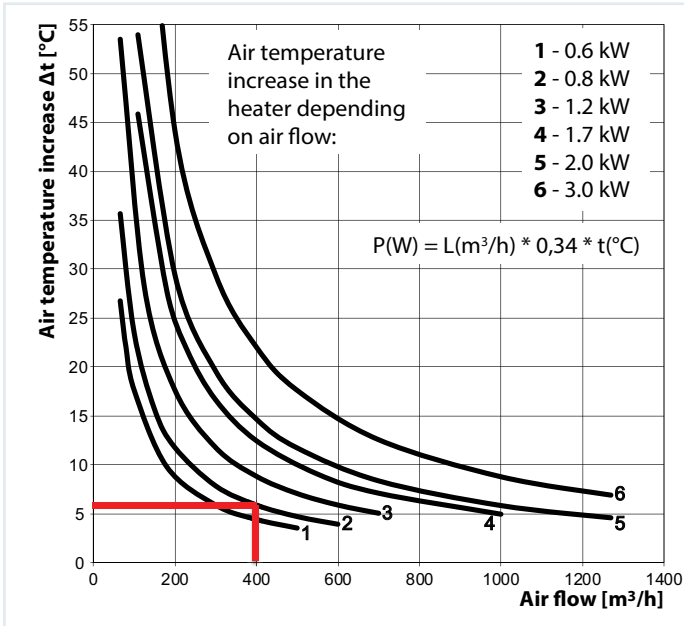

The NKD heater parameters calculation example:

It is necessary to select a heater for supply air post-heating to a temperature of +24 °C, provided the temperature downstream of the heat exchanger is +17 °C. Therefore, it is essential to increase temperature by 7 °C. The ventilation system incorporates the VENTS VUT 350 VB EC A21 air handling unit. The rated air flow is 400 m³/h. Determine the intersection of the post-heating temperature line (+7 °C) and the rated air flow line (400 m³/h).

In this case the 1200 W heater capacity provides necessary post-heating (+7 °C). The NKD heater 160-1.2-1 kW with the diameter matching the spigot diameter of the VUT 350 VB EC A21 air handling unit is a suitable model.

