

USER'S MANUAL

AV01 UVU 1000 ... A30/31/32

AV02 UVU 2000 ... A30/31/32

AV04 UVU 4000 ... A30/31/32

AV06 UVU 6000 ... A30/31/32

AV06 UVU 8000 ... A30/31/32

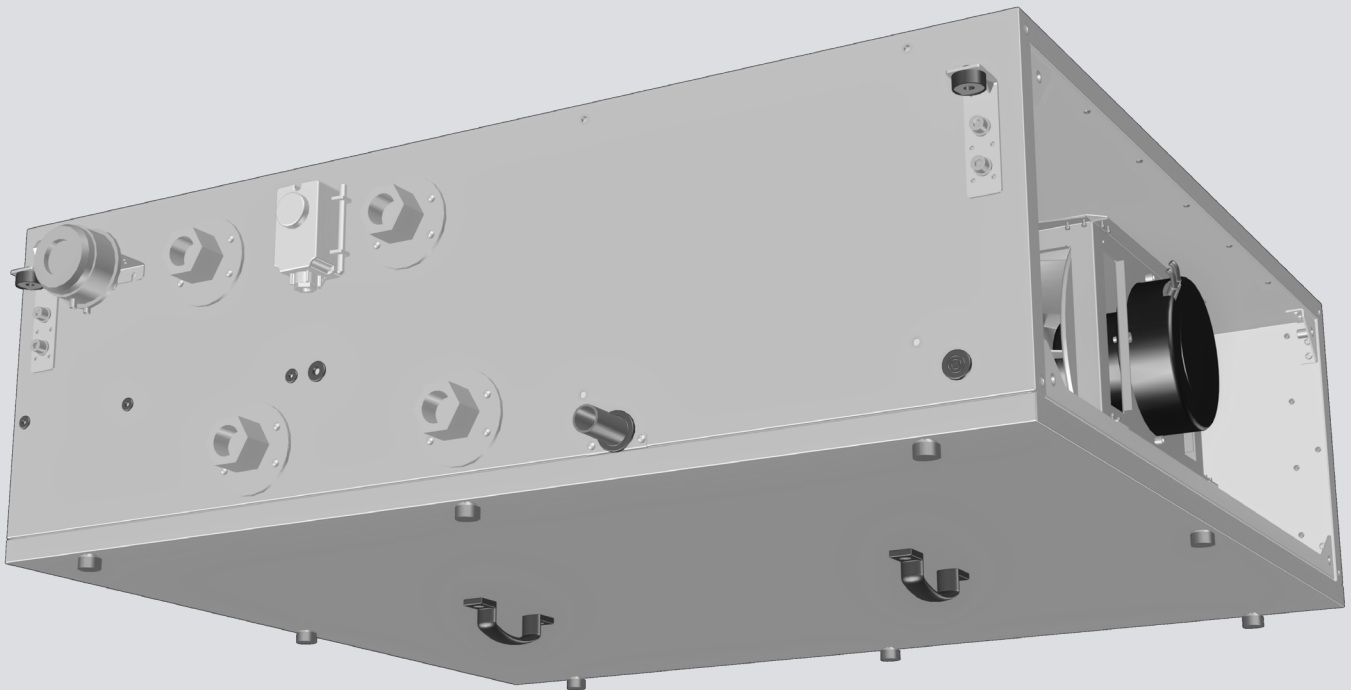

Unidirectional ventilation units

CONTENTS

Safety requirements.....	3
Purpose.....	5
Delivery set*	5
Designation key.....	5
Technical data.....	6
Design and operating principle	11
Unit transportation.....	14
Mounting and set-up.....	15
Connection to power mains	19
Automation.....	21
Starting setup	49
Trial run	50
Technical maintenance.....	51
Troubleshooting.....	52
Final measurement of operating parameters.....	52
Storage and transportation regulations.....	52
Manufacturer's warranty.....	53
Certificate of acceptance.....	55
Seller information	55
Installation certificate.....	55
Warranty card.....	55

This user's manual is a main operating document intended for technical, maintenance, and operating staff.

The manual contains information about purpose, technical details, operating principle, design, and installation of the Airvents AV01/02/04/06 UVU unit and all its modifications.

Technical and maintenance staff must have theoretical and practical training in the field of ventilation systems and should be able to work in accordance with workplace safety rules as well as construction norms and standards applicable in the territory of the country.

SAFETY REQUIREMENTS

This unit is not intended for use by persons (including children) with reduced physical, sensory or mental capabilities, or lack of experience and knowledge, unless they have been given supervision or instruction concerning use of the unit by a person responsible for their safety.

Children should be supervised to ensure that they do not play with the unit.

This appliance can be used by children aged from 8 years and above and persons with reduced physical, sensory or mental capabilities or lack of experience and knowledge if they have been given supervision or instruction concerning use of the appliance in a safe way and understand the hazards involved.

Cleaning and user maintenance shall not be done by children without supervision.

Children shall not play with the appliance.

This appliance incorporates a grounding connection for functional purposes only.

Connection to the mains must be made through a disconnecting device, which is integrated into the fixed wiring system in accordance with the wiring rules for design of electrical units, and has a contact separation in all poles that allows for full disconnection under overvoltage category III conditions.

If the supply cord is damaged, it must be replaced by the manufacturer, its service agent, or similarly qualified persons in order to avoid a safety hazard.

CAUTION: In order to avoid a safety hazard due to inadvertent resetting of the thermal cut-out, this unit must not be supplied through an external switching device, such as a timer, or connected to a circuit that is regularly switched on and off by the utility.

Ensure that the unit is switched off from the supply mains before removing the guard.

WARNING: If there are any unusual oscillating movements, immediately stop using the unit and contact the manufacturer, its service agent or suitably qualified persons.

The replacement of parts of the safety suspension system device shall be performed by the manufacturer, its service agent or suitably qualified persons.

Precautions must be taken to avoid the back-flow of gases into the room from the open flue of gas or other fuel-burning appliances.

The appliance may adversely affect the safe operation of appliances burning gas or other fuels (including those in other rooms) due to back flow of combustion gases. These gases can potentially result in carbon monoxide poisoning. After installation of the unit the operation of flued gas appliances should be tested by a competent person to ensure that back flow of combustion gases does not occur.

All operations described in this manual must be performed by qualified personnel only, properly trained and qualified to install, make electrical connections and maintain ventilation units.

Do not attempt to install the product, connect it to the mains, or perform maintenance yourself. This is unsafe and impossible without special knowledge.

Disconnect the power supply prior to any operations with the unit.

All user's manual requirements as well as the provisions of all the applicable local and national construction, electrical, and technical norms and standards must be observed when installing and operating the unit.

Disconnect the unit from the power supply prior to any connection, servicing, maintenance, and repair operations.

Connection of the unit to power mains is allowed by a qualified electrician with a work permit for the electric units up to 1000 V after careful reading of the present user's manual.

Check the unit for any visible damage of the impeller, the casing, and the grille before starting installation. The casing internals must be free of any foreign objects that can damage the impeller blades.

While mounting the unit, avoid compression of the casing! Deformation of the casing may result in motor jam and excessive noise.

Misuse of the unit and any unauthorised modifications are not allowed.

Do not expose the unit to adverse atmospheric agents (rain, sun, etc.).

Transported air must not contain any dust or other solid impurities, sticky substances, or fibrous materials.

Do not use the unit in a hazardous or explosive environment containing spirits, gasoline, insecticides, etc.

Do not close or block the intake or extract vents in order to ensure the efficient air flow.

Do not sit on the unit and do not put objects on it.

The information in this user's manual was correct at the time of the document's preparation.

The Company reserves the right to modify the technical characteristics, design, or configuration of its products at any time in order to incorporate the latest technological developments.

Never touch the unit with wet or damp hands.

Never touch the unit when barefoot.

BEFORE INSTALLING ADDITIONAL EXTERNAL DEVICES, READ THE RELEVANT USER MANUALS.



**THE PRODUCT MUST BE DISPOSED SEPARATELY AT THE END OF ITS SERVICE LIFE.
DO NOT DISPOSE THE UNIT AS UNSORTED DOMESTIC WASTE.**

PURPOSE

The unit is designed to filter, supply, heat up or cool down the supply purified air in houses, offices, hotels, cafés, conference halls, and other utility and public spaces.

Transported air must not contain any flammable or explosive mixtures, evaporation of chemicals, sticky substances, fibrous materials, coarse dust, soot and oil particles or environments favourable for the formation of hazardous substances (toxic substances, dust, pathogenic germs).

The unit must not be used for purposes other than those specified in this manual or outside the ambient conditions specified herein. The unit is rated for continuous operation.

DELIVERY SET*

Name	Quantity
UVU unit	1 pc.
Remote control	1 pc.
Inline outdoor air temperature sensor	1 pc.
Inline supply air temperature sensor	1 pc.
User's manual	1 pc.
Packing box	1 pc.

*The delivery set may be extended with additional options based on the technical selection

DESIGNATION KEY

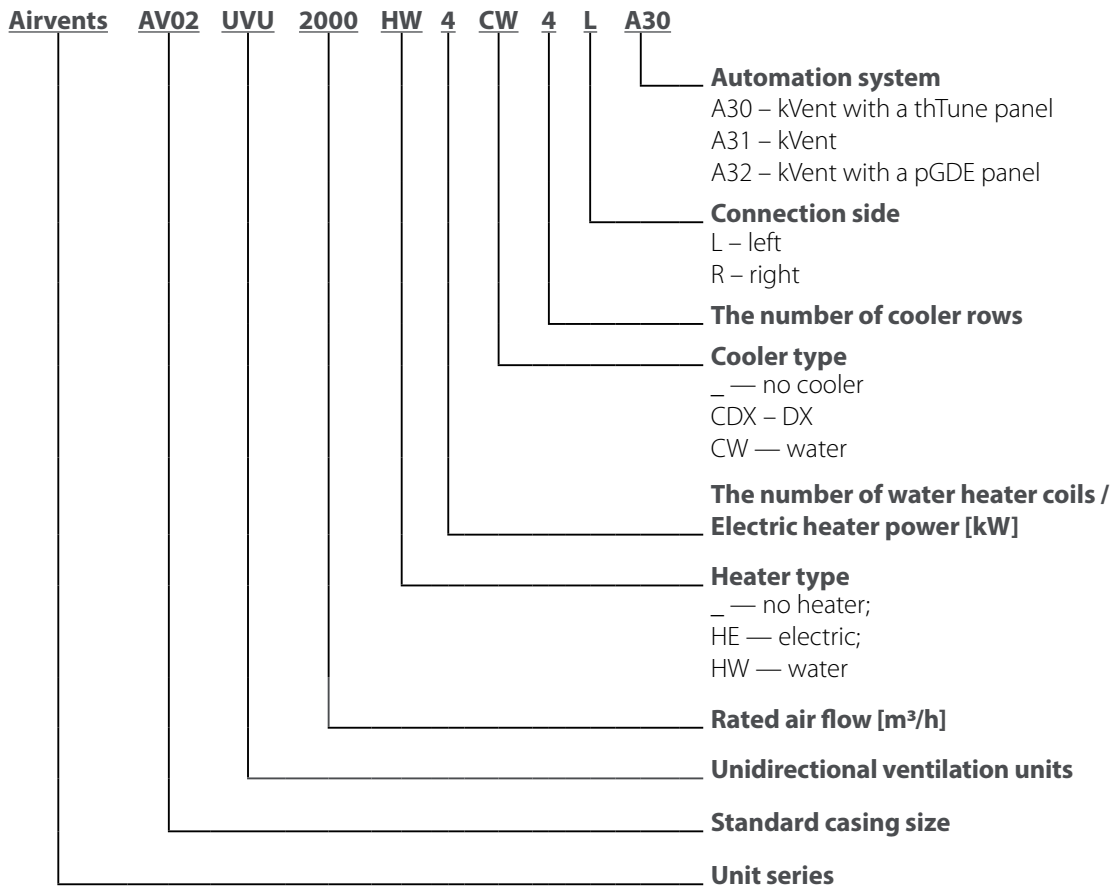

TECHNICAL DATA

The product is used either in a closed room or under a canopy. In case of low negative ambient temperatures, the drainage and the pipework systems connected to the unit must be provided with frost protection. In water heat exchangers (if any), the appropriate heat medium temperature must be ensured and a glycol mixture must be used to make its freezing impossible.

The unit is rated as a class I electric appliance.

Hazardous parts access and water ingress protection rating:

- IP00 for the unit not connected to air ducts.
- IP22 for the unit connected to air ducts;
- IP44 for the unit motors.

The unit design is constantly being improved, thus some models may be slightly different from those described in this manual.

Overall and connection dimensions of the models

Model	Electric heater	Water heater	Water cooler	DX cooler	Overall and connection dimensions of the casing
AV01 UVU 1000-HE9,0-CW2	+	-	+	-	Fig. 2
AV01 UVU 1000-HE9,0-CW4	+	-	+	-	Fig. 2
AV01 UVU 1000-HE9,0-CDX2	+	-	-	+	Fig. 2
AV01 UVU 1000-HE9,0-CDX4	+	-	-	+	Fig. 2
AV01 UVU 1000-HE18,0-CW2	+	-	+	-	Fig. 2
AV01 UVU 1000-HE18,0-CW4	+	-	+	-	Fig. 2
AV01 UVU 1000-HE18,0-CDX2	+	-	-	+	Fig. 2
AV01 UVU 1000-HE18,0-CDX4	+	-	-	+	Fig. 2
AV01 UVU 1000-HW2-CW2	-	+	+	-	Fig. 2
AV01 UVU 1000-HW2-CW4	-	+	+	-	Fig. 2
AV01 UVU 1000-HW4-CW2	-	+	+	-	Fig. 2
AV01 UVU 1000-HW4-CW4	-	+	+	-	Fig. 2
AV01 UVU 1000-HW2-CDX2	-	+	-	+	Fig. 2
AV01 UVU 1000-HW2-CDX4	-	+	-	+	Fig. 2
AV01 UVU 1000-HW4-CDX2	-	+	-	+	Fig. 2
AV01 UVU 1000-HW2-CDX4	-	+	-	+	Fig. 2
AV01 UVU 1000-HE18,0	+	-	-	-	Fig. 1
AV01 UVU 1000-HE9,0	+	-	-	-	Fig. 1
AV01 UVU 1000-HW2	-	+	-	-	Fig. 1
AV01 UVU 1000-CW2	-	-	+	-	Fig. 1
AV01 UVU 1000-HW4	-	+	-	-	Fig. 1
AV01 UVU 1000-CW4	-	-	+	-	Fig. 1
AV01 UVU 1000-CDX2	-	-	-	+	Fig. 1
AV01 UVU 1000-CDX4	-	-	-	+	Fig. 1
AV01 UVU 1000	-	-	-	-	Fig. 1
AV02 UVU 2000-HE18,0-CW2	+	-	+	-	Fig. 2
AV02 UVU 2000-HE18,0-CW4	+	-	+	-	Fig. 2
AV02 UVU 2000-HE18,0-CDX2	+	-	-	+	Fig. 2
AV02 UVU 2000-HE18,0-CDX4	+	-	-	+	Fig. 2
AV02 UVU 2000-HE36,0-CW2	+	-	+	-	Fig. 2
AV02 UVU 2000-HE36,0-CW4	+	-	+	-	Fig. 2
AV02 UVU 2000-HE36,0-CDX2	+	-	-	+	Fig. 2
AV02 UVU 2000-HE36,0-CDX4	+	-	-	+	Fig. 2
AV02 UVU 2000-HW2-CW2	-	+	+	-	Fig. 2
AV02 UVU 2000-HW2-CW4	-	+	+	-	Fig. 2
AV02 UVU 2000-HW4-CW2	-	+	+	-	Fig. 2
AV02 UVU 2000-HW4-CW4	-	+	+	-	Fig. 2
AV02 UVU 2000-HW2-CDX2	-	+	-	+	Fig. 2
AV02 UVU 2000-HW2-CDX4	-	+	-	+	Fig. 2
AV02 UVU 2000-HW4-CDX2	-	+	-	+	Fig. 2

Model	Electric heater	Water heater	Water cooler	DX cooler	Overall and connection dimensions of the casing
AV02 UVU 2000-HW4-CDX4	-	+	-	+	Fig. 2
AV02 UVU 2000-HE36,0	+	-	-	-	Fig. 1
AV02 UVU 2000-HE18,0	+	-	-	-	Fig. 1
AV02 UVU 2000-HW2	-	+	-	-	Fig. 1
AV02 UVU 2000-CW2	-	-	+	-	Fig. 1
AV02 UVU 2000-HW4	-	+	-	-	Fig. 1
AV02 UVU 2000-CW4	-	-	+	-	Fig. 1
AV02 UVU 2000-CDX2	-	-	-	+	Fig. 1
AV02 UVU 2000-CDX4	-	-	-	+	Fig. 1
AV02 UVU 2000	-	-	-	-	Fig. 1
AV04 UVU 4000-HE36,0-CW2	+	-	+	-	Fig. 2
AV04 UVU 4000-HE36,0-CW4	+	-	+	-	Fig. 2
AV04 UVU 4000-HE36,0-CDX2	+	-	-	+	Fig. 2
AV04 UVU 4000-HE36,0-CDX4	+	-	-	+	Fig. 2
AV04 UVU 4000-HE72,0-CW2	+	-	+	-	Fig. 2
AV04 UVU 4000-HE72,0-CW4	+	-	+	-	Fig. 2
AV04 UVU 4000-HE72,0-CDX2	+	-	-	+	Fig. 2
AV04 UVU 4000-HE72,0-CDX4	+	-	-	+	Fig. 2
AV04 UVU 4000-HW2-CW2	-	+	+	-	Fig. 2
AV04 UVU 4000-HW2-CW4	-	+	+	-	Fig. 2
AV04 UVU 4000-HW4-CW2	-	+	+	-	Fig. 2
AV04 UVU 4000-HW4-CW4	-	+	+	-	Fig. 2
AV04 UVU 4000-HW2-CDX2	-	+	-	+	Fig. 2
AV04 UVU 4000-HW2-CDX4	-	+	-	+	Fig. 2
AV04 UVU 4000-HW4-CDX2	-	+	-	+	Fig. 2
AV04 UVU 4000-HW4-CDX4	-	+	-	+	Fig. 2
AV04 UVU 4000-HE72,0	+	-	-	-	Fig. 1
AV04 UVU 4000-HE36,0	+	-	-	-	Fig. 1
AV04 UVU 4000-CW2	-	-	+	-	Fig. 1
AV04 UVU 4000-HW2	-	+	-	-	Fig. 1
AV04 UVU 4000-HW4	-	+	-	-	Fig. 1
AV04 UVU 4000-CW4	-	-	+	-	Fig. 1
AV04 UVU 4000-CDX2	-	-	-	+	Fig. 1
AV04 UVU 4000-CDX4	-	-	-	+	Fig. 1
AV04 UVU 4000	-	-	-	-	Fig. 1
AV06 UVU 6000-HE48,0-CW2	+	-	+	-	Fig. 2
AV06 UVU 6000-HE48,0-CW4	+	-	+	-	Fig. 2
AV06 UVU 6000-HE48,0-CDX2	+	-	-	+	Fig. 2
AV06 UVU 6000-HE48,0-CDX4	+	-	-	+	Fig. 2
AV06 UVU 6000-HE96,0-CW2	+	-	+	-	Fig. 2
AV06 UVU 6000-HE96,0-CW4	+	-	+	-	Fig. 2
AV06 UVU 6000-HE96,0-CDX2	+	-	-	+	Fig. 2
AV06 UVU 6000-HE96,0-CDX4	+	-	-	+	Fig. 2
AV06 UVU 6000-HW2-CW2	-	+	+	-	Fig. 2
AV06 UVU 6000-HW2-CW4	-	+	+	-	Fig. 2
AV06 UVU 6000-HW4-CW2	-	+	+	-	Fig. 2
AV06 UVU 6000-HW4-CW4	-	+	+	-	Fig. 2
AV06 UVU 6000-HW2-CDX2	-	+	-	+	Fig. 2
AV06 UVU 6000-HW2-CDX4	-	+	-	+	Fig. 2
AV06 UVU 6000-HW4-CDX2	-	+	-	+	Fig. 2
AV06 UVU 6000-HW4-CDX4	-	+	-	+	Fig. 2
AV06 UVU 6000-HE96,0	+	-	-	-	Fig. 1

Model	Electric heater	Water heater	Water cooler	DX cooler	Overall and connection dimensions of the casing
AV06 UVU 6000-HE48,0	+	-	-	-	Fig. 1
AV06 UVU 6000-HW2	-	+	-	-	Fig. 1
AV06 UVU 6000-CW2	-	-	+	-	Fig. 1
AV06 UVU 6000-HW4	-	+	-	-	Fig. 1
AV06 UVU 6000-CW4	-	-	+	-	Fig. 1
AV06 UVU 6000-CDX2	-	-	-	+	Fig. 1
AV06 UVU 6000-CDX4	-	-	-	+	Fig. 1
AV06 UVU 6000	-	-	-	-	Fig. 1
AV06 UVU 8000-HE72,0-CW2	+	-	+	-	Fig. 2
AV06 UVU 8000-HE72,0-CW4	+	-	+	-	Fig. 2
AV06 UVU 8000-HE72,0-CDX2	+	-	-	+	Fig. 2
AV06 UVU 8000-HE72,0-CDX4	+	-	-	+	Fig. 2
AV06 UVU 8000-HW2-CW2	-	+	+	-	Fig. 2
AV06 UVU 8000-HW2-CW4	-	+	+	-	Fig. 2
AV06 UVU 8000-HW4-CW2	-	+	+	-	Fig. 2
AV06 UVU 8000-HW4-CW4	-	+	+	-	Fig. 2
AV06 UVU 8000-HW2-CDX2	-	+	-	+	Fig. 2
AV06 UVU 8000-HW2-CDX4	-	+	-	+	Fig. 2
AV06 UVU 8000-HW4-CDX2	-	+	-	+	Fig. 2
AV06 UVU 8000-HW4-CDX4	-	+	-	+	Fig. 2
AV06 UVU 8000-HE72,0	+	-	-	-	Fig. 1
AV06 UVU 8000-HW2	+	-	-	-	Fig. 1
AV06 UVU 8000-HW4	+	-	-	-	Fig. 1
AV06 UVU 8000-CW2	-	-	+	-	Fig. 1
AV06 UVU 8000-CW4	-	-	+	-	Fig. 1
AV06 UVU 8000-CDX2	-	-	-	+	Fig. 1
AV06 UVU 8000-CDX4	-	-	-	+	Fig. 1
AV06 UVU 8000-HE144,0-CW2	+	-	+	-	Fig. 2
AV06 UVU 8000-HE144,0-CW4	+	-	+	-	Fig. 2
AV06 UVU 8000-HE144,0-CDX2	+	-	-	-	Fig. 2
AV06 UVU 8000-HE144,0-CDX4	+	-	-	-	Fig. 2
AV06 UVU 8000-HE144,0	+	-	-	-	Fig. 1
AV06 UVU 8000	-	-	-	-	Fig. 1

Overall and connection dimensions of the models' casings

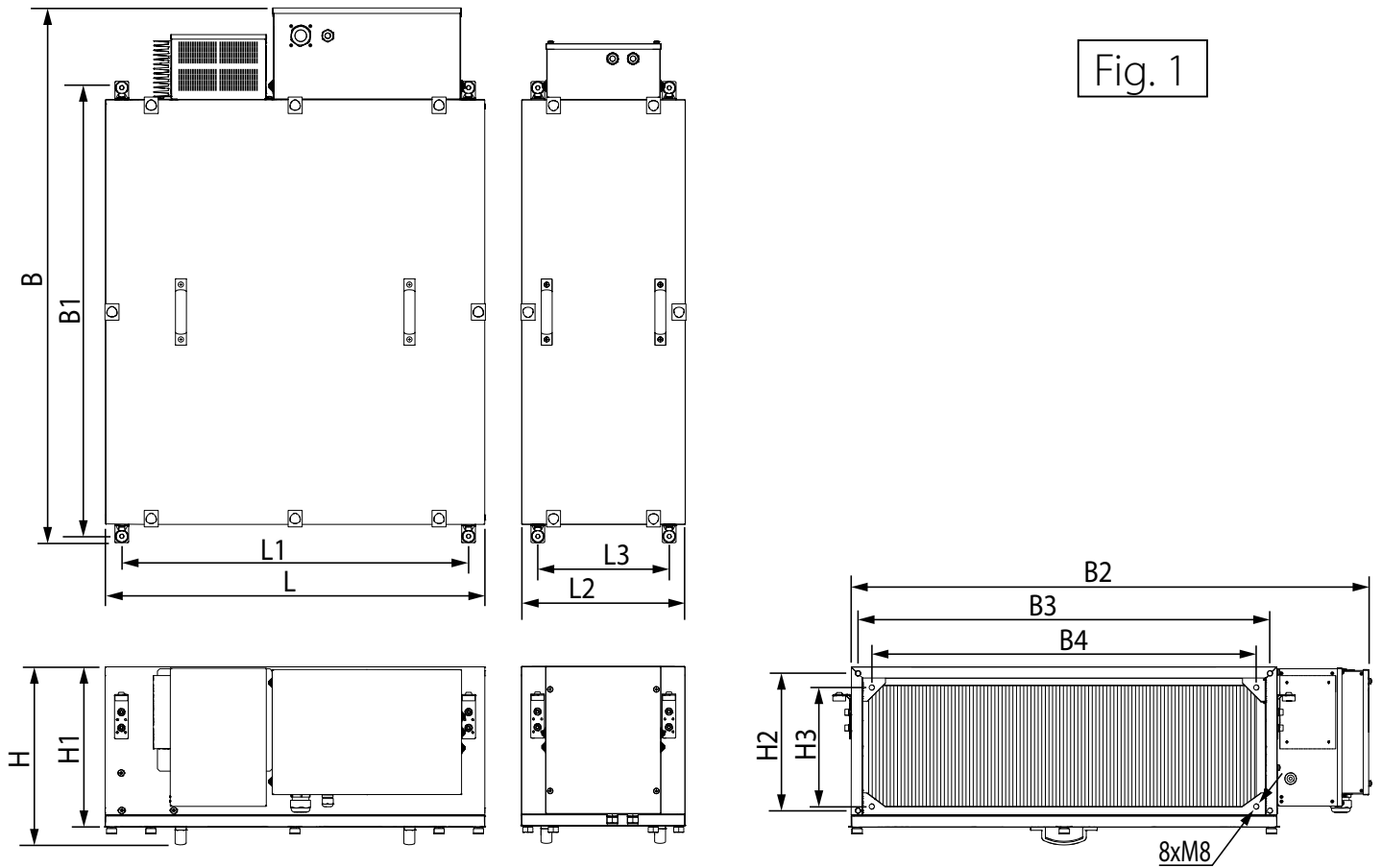
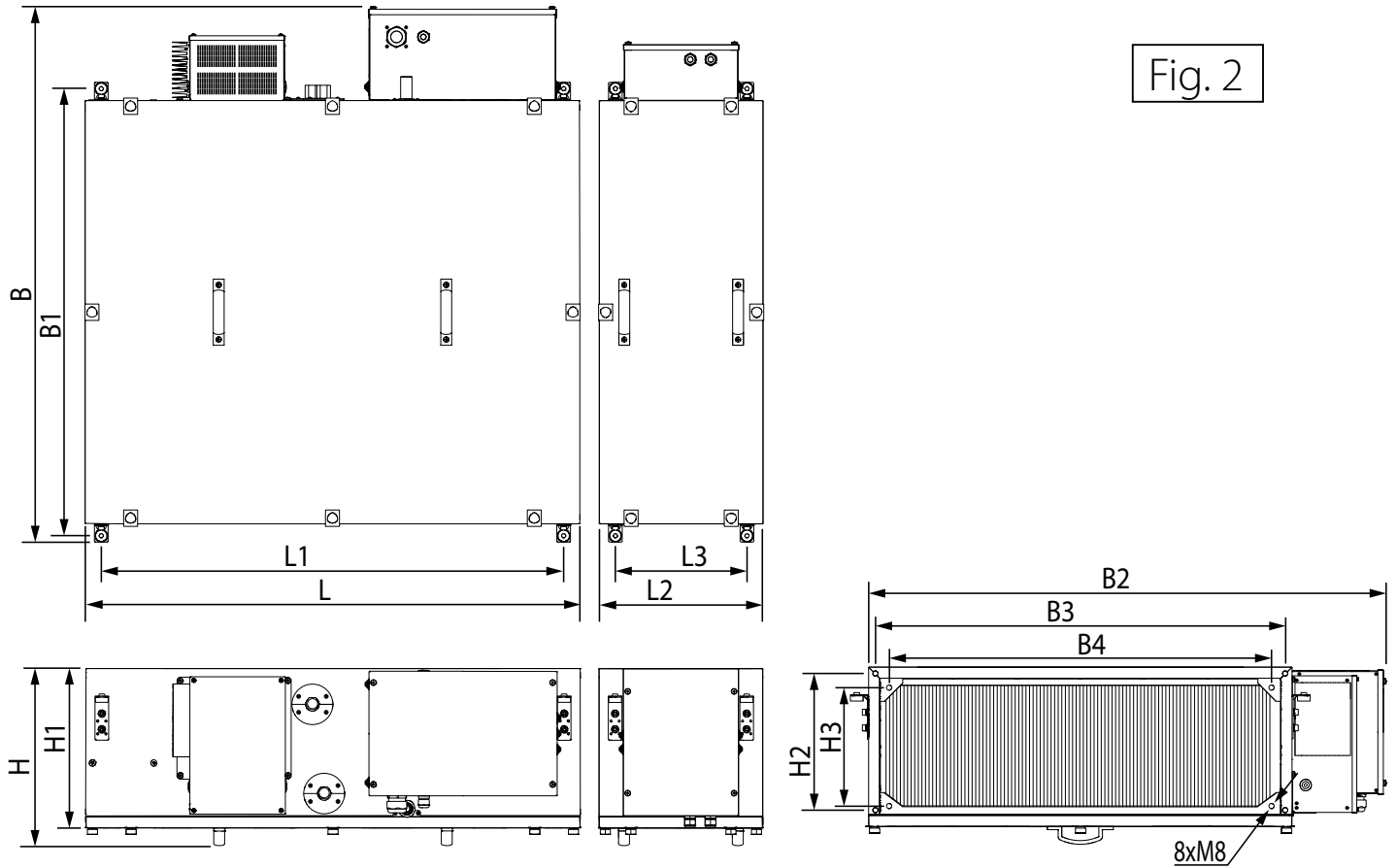

Fig. 1

Standard casing size	L	L1	L2	L3	H	H1	H2	H3	B	B1	B2	B3	B4
AV01	830	760	360	290	390	350	300	260	730	542	620	460	400
AV02	830	760	360	290	390	350	300	260	1170	982	1060	900	840
AV04	1300	1227	360	290	520	480	440	400	1650	1462	1540	1390	1330
AV06	1300	1227	360	290	660	620	582	540	1825	1632	1710	1560	1500



Standard casing size	L	L1	L2	L3	H	H1	H2	H3	B	B1	B2	B3	B4
AV01	1087	1016	360	290	390	350	300	260	730	542	620	460	400
AV02	1087	1016	360	290	390	350	300	260	1170	982	1060	900	840
AV04	1600	1527	360	290	520	480	440	400	1650	1462	1540	1390	1330
AV06	1600	1527	360	290	660	620	582	540	1825	1632	1710	1560	1500

Technical specifications of the particular model are indicated on the unit casing.



DESIGN AND OPERATING PRINCIPLE

The unit's casing (item 1) is made from the following materials: the external panel – aluminum zinc, the internal panel – galvanized steel. The unit casing has mounting brackets with anti-vibration connectors for ceiling mounting (item 2).

The air flow direction is indicated by the arrow on the fan casing.

The bottom side of the casing is covered with a removable cover (item 3), which is secured with screws with a plastic handle (item 4).

There is a differential pressure switch installed on the unit casing to monitor the filter clogging (item 5).

The unit may be equipped with an electric heater, water heater, water or DX cooler.

The units equipped with a water heater also have a thermal switch on the casing to protect the heat medium in the heater from freezing (item 6).

The units equipped with coolers also have a spigot for condensate drainage (drain pipe) (item 7).

The side surfaces of the units can have openings for connecting the heat medium supply and return pipes (item 8) of water heat exchangers and openings for connecting a DX cooler (item 9).

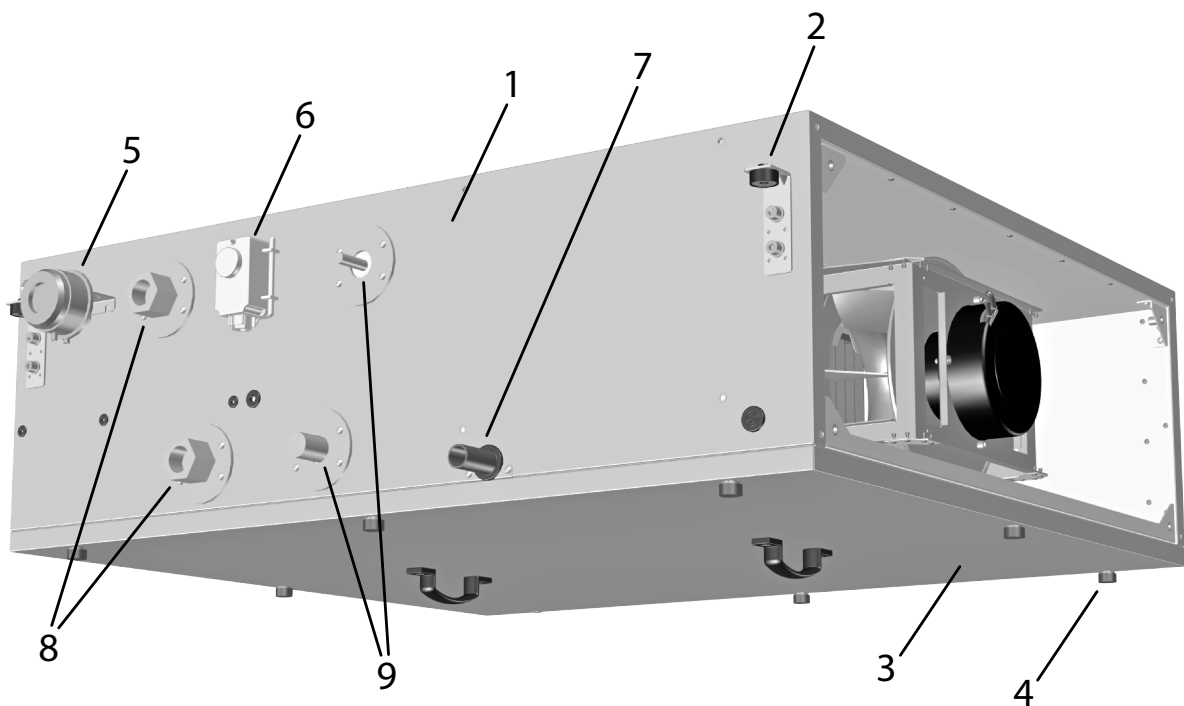

The figure below shows the internals of the left and right version of the units with the removable cover removed. The air flow direction is indicated by the arrows.

- air filter with G4 filtration class (item 1);
- electric heater (item 2);
- mounting bracket with two thermal switches secured on it (item 3).
- water cooler (item 4);
- fan unit (item 5);
- additional electric heating section (item 6);
- water heater (item 7);
- DX cooler (item 8).

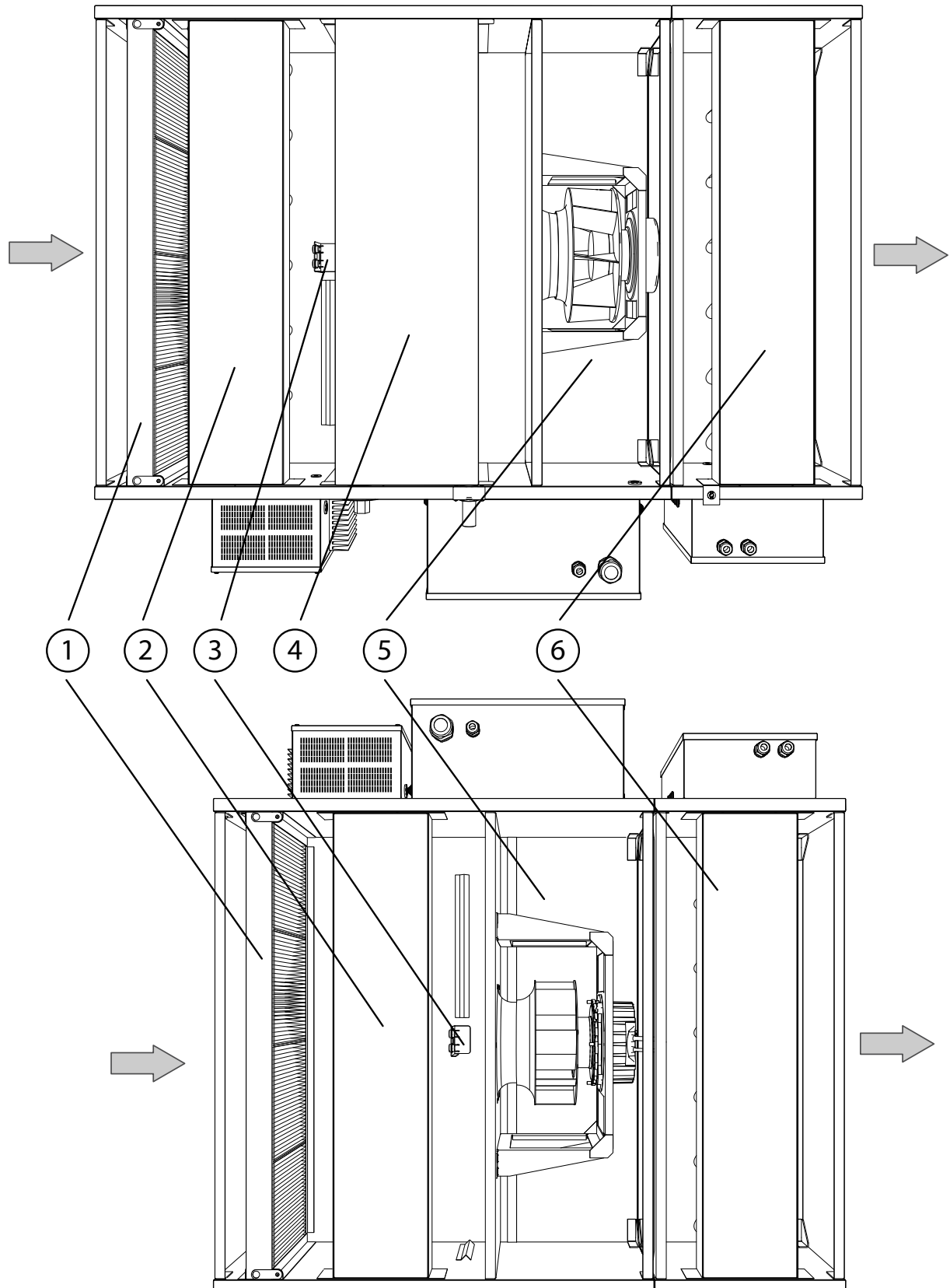

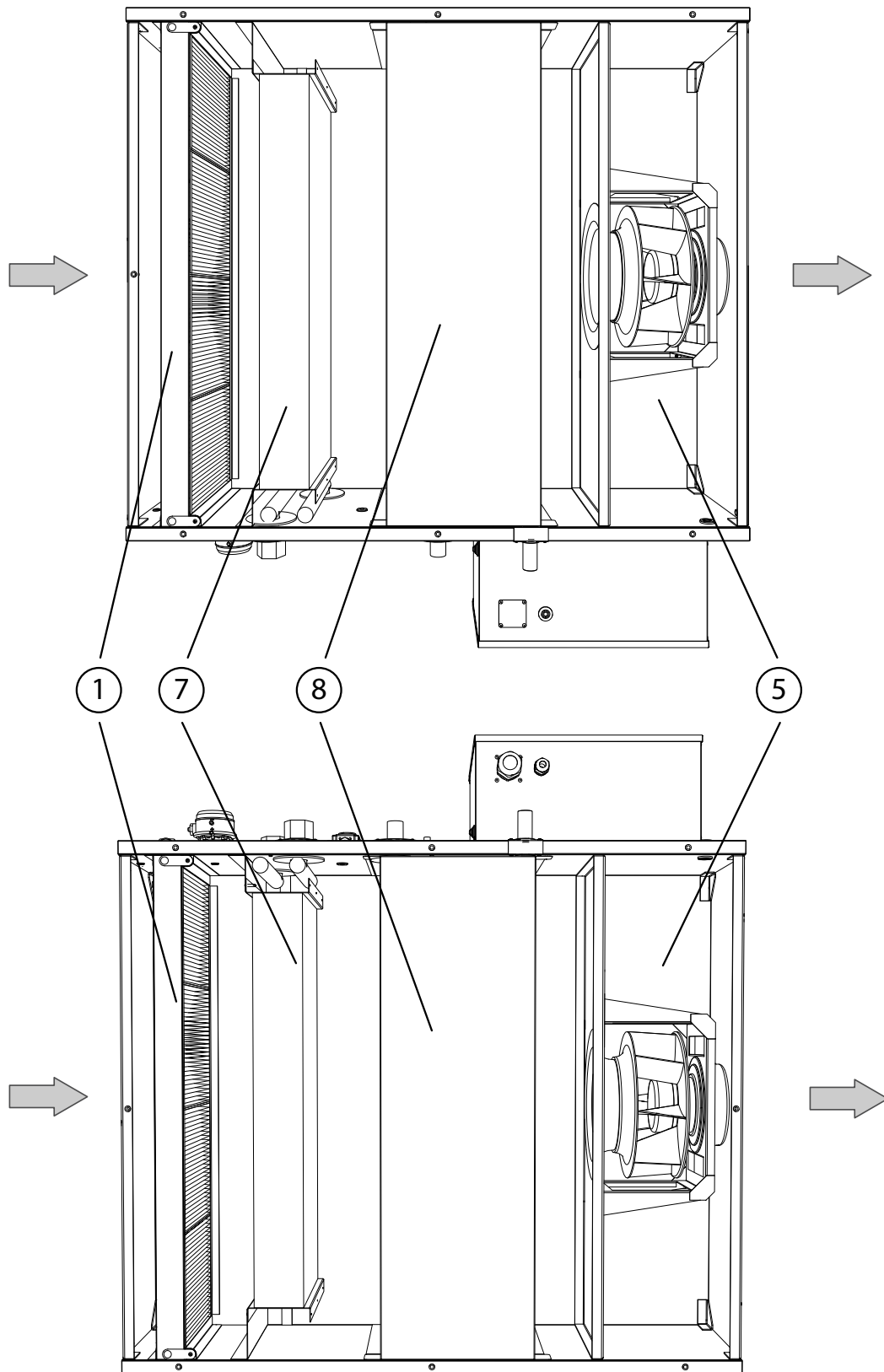

The unit supplies heated and filtered outdoor air into the room.

The unit uses a frameless centrifugal fan directly driven by an external rotor motor. The fan impeller blades are curved backwards. The motor is equipped with built-in thermal protection.

After filtration, the air passes through the electric or water heater.

To maintain the set temperature in the supply air duct, if the unit is equipped with an electric heater, the automatic control system adjusts the electric heater power, or the heat medium flow through the water heater in units equipped with a water heater.

To maintain the set air temperature in the supply air duct in summer, the automatic control system of the unit with a cooler adjusts the flow of the coolant through the heat exchanger.

UNIT TRANSPORTATION

Store and transport the unit in the manufacturer's original packaging box only.

Adequately secure the units before transporting and set additional protection to prevent potential mechanical damage or precipitation ingress.

Hoisting and handling operations can only be performed by qualified professionals authorized to handle hoisting equipment and knows the corresponding principles and security requirements.

When using a forklift truck to hoist and transport units, its forks must be long enough to avoid rolling over or damaging the casing of the unit being lifted.

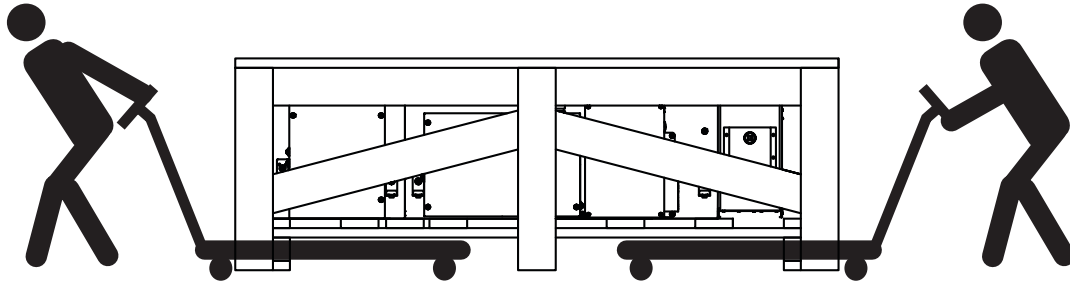

Depending on the standard size and weight of the unit (all the details are specified on labels on the unit), it can be loaded or unloaded using special transporting equipment: a crane, cross-bar or forklift truck.

To protect the sides of the equipment, protective bars are installed on the unit. The length varies depending on the unit size. A cross-bar is also designed for handling operations. Regardless of the equipment used, the side panels must always be protected to prevent damage by the forklift or cables.

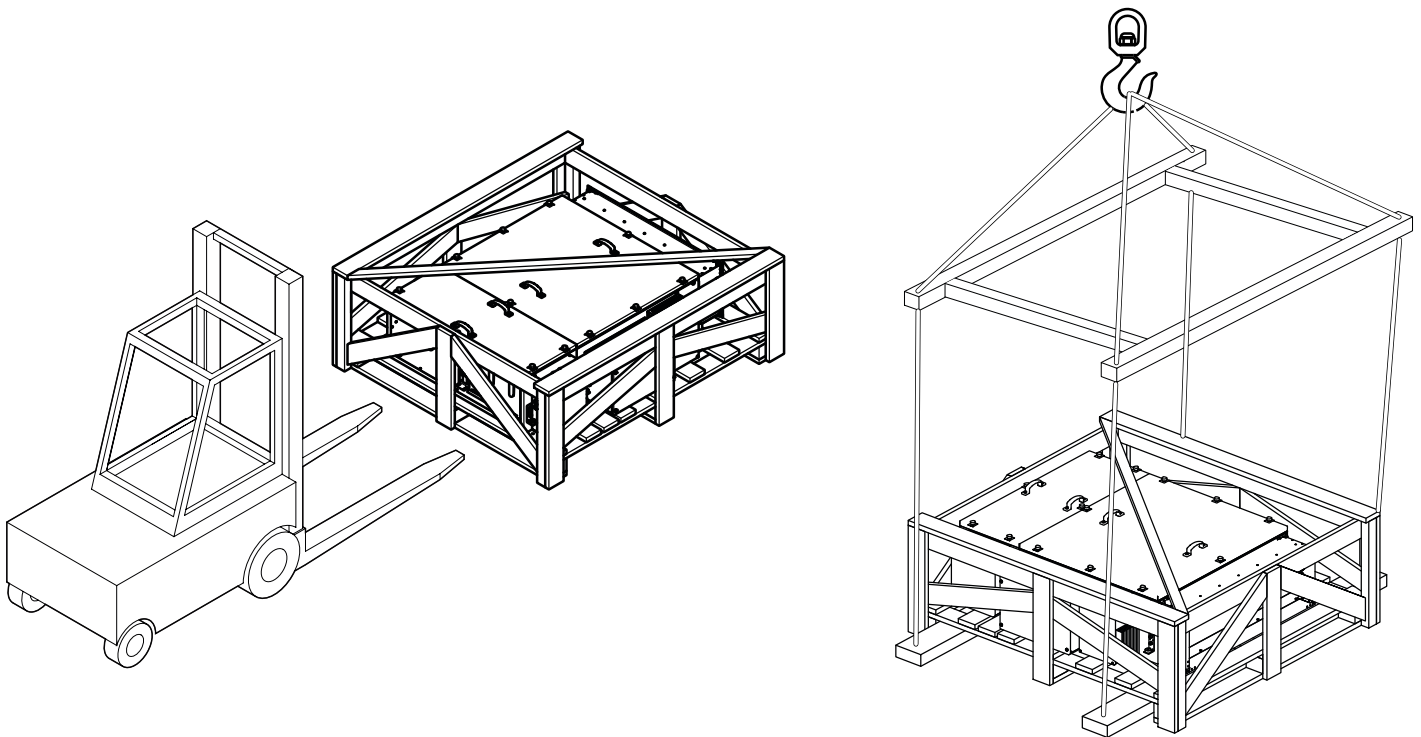

MOUNTING AND SET-UP



**READ THE USERS MANUAL BEFORE INSTALLING THE UNIT.
BEFORE INSTALLING ADDITIONAL EXTERNAL DEVICES,
READ THE APPROPRIATE USER MANUALS**



**ALL OPERATIONS DESCRIBED IN THIS USER'S MANUAL MUST BE PERFORMED BY
QUALIFIED PERSONNEL ONLY, PROPERLY TRAINED AND QUALIFIED TO INSTALL AND
MAINTAIN VENTILATION EQUIPMENT.
DO NOT ATTEMPT TO INSTALL THE PRODUCT YOURSELF.
IT IS UNSAFE AND IMPOSSIBLE WITHOUT SPECIAL KNOWLEDGE**



**WHILE INSTALLING THE UNIT ENSURE CONVENIENT ACCESS FOR SUBSEQUENT
MAINTENANCE AND REPAIR.**

The units are designed for ceiling mounting and are installed in rectangular ductwork. The air ducts are connected directly to the unit casing.

The units are installed between the ducts, taking into account the direction of air flow, which is indicated by an arrow on the casing.

Warning!

- To reduce aerodynamic losses related to air flow turbulence, use shaped reducers in order to reduce or increase the cross-section of air ducts.
- To minimise turbulence-induced air pressure losses, connect the straight air duct sections on both sides of the unit. The minimum straight air duct length is equal to: 1 air duct diameter on intake side and 3 air duct diameters on outlet side
- It is necessary to protect the internal parts of the unit from foreign objects entering inside. For example, install a grill with a cell side size of no more than 12.5 mm to prevent free access to the fan and foreign objects from entering the unit.
- It is recommended to connect the duct through a flexible connection to reduce noise and vibration transmission. Such connections make it possible to compensate for possible mounting inaccuracies when connecting the unit to air ducts.
- The equipment and air ducts that are to be connected must have their own mounting bracket in order to avoid transferring their own weight loads to the unit.

The unit must be mounted so that it can be accessed for service purposes. Enough space must be provided for the cover to open all the way. After unscrewing the screws, the cover will hang on special cables.

The mounting is carried out at 4 points with mounting brackets. It is recommended to use anchor threaded rods with nuts for fastening the unit.

Fasteners for the unit mounting are not included into delivery set and should be ordered separately. While choosing fasteners consider the material of the mounting surface and the unit weight. For selection of the fasteners for unit mounting, please refer to a service technician.

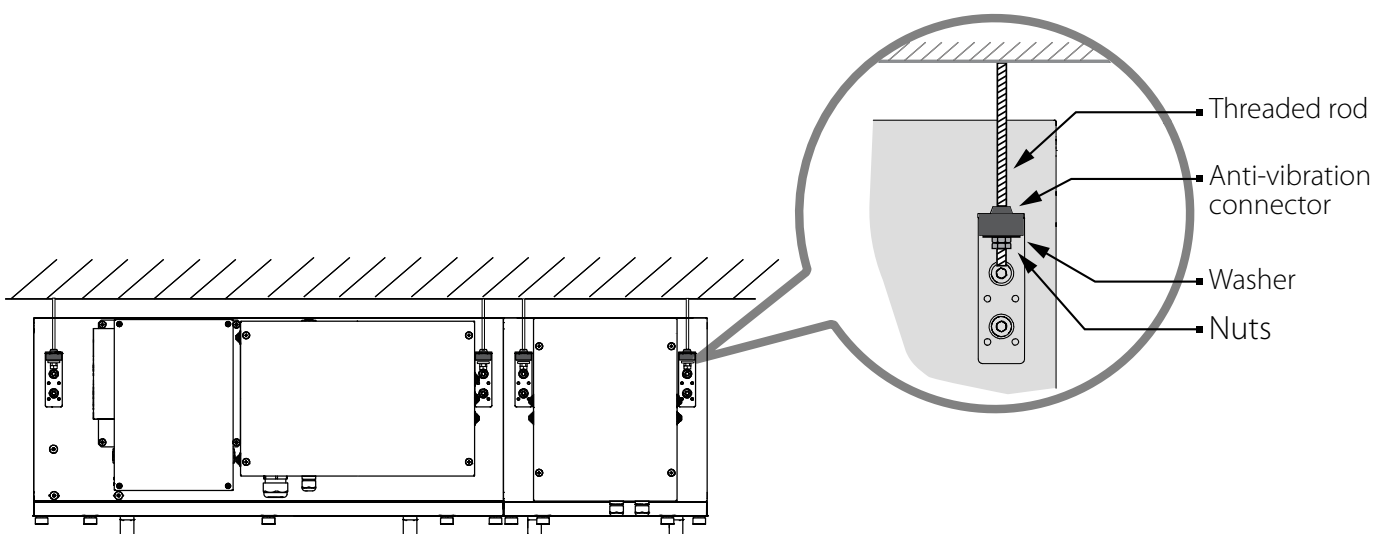

The ventilation units are designed as monoblock units with additional accessories: heating, cooling, which are located inside the unit's casing. The electric heater (preheater) may partially be located outside of the unit casing, in a separate section, if there is not enough room available for installation of the desired power option of the preheater inside the casing. Accessories: inline adapters, silencers are available.

If, for some reason, the unit sections were disassembled while installing in the operational location, the unit's airtightness may not correspond to the data specified in the documents (unless the unit was assembled by the manufacturer's qualified personnel). Connect all the cables leading to sections of the unit prior to attaching sections themselves.

- Sealant (included in the delivery set) must be applied to gaps in between the sections
- Do not screw in screws or drill through the casing of the unit (unless intended by design) to avoid damaging cables and tubes inside.

The figure below shows a typical approximate composition of the ventilation system

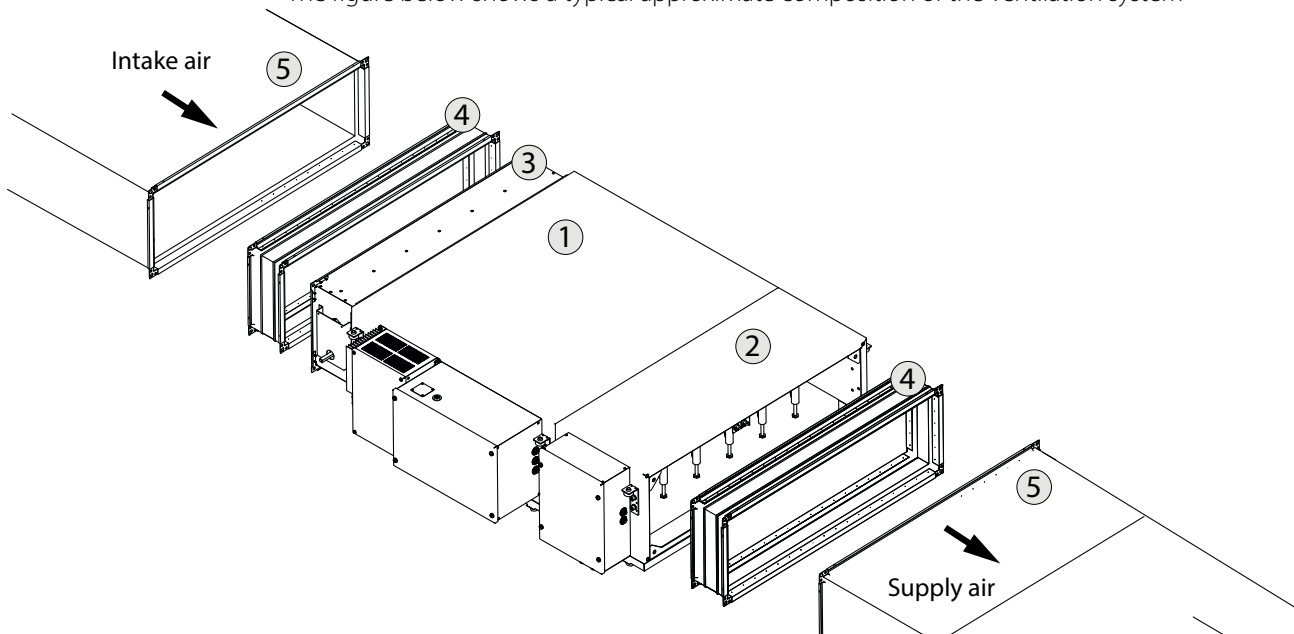

1 – Right-handed design of the unit; 2 – Electric reheater; 3 – Louver valve;
4 – Flexible joint; 5 – Rectangular air duct.

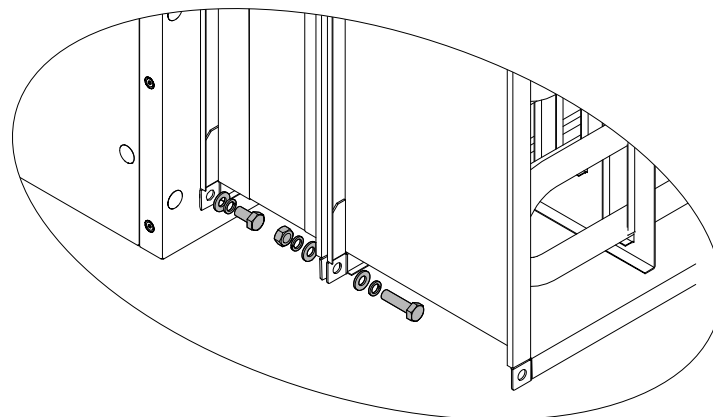

Use fasteners as shown in the figure to connect the optional accessories to the unit and to each other. For sealing, apply the supplied self-adhesive sealing tape to the surfaces of the flanges to be joined.

Connecting a water heat exchanger and a DX cooler

Do not apply mechanical pressure (force) to the pipes while connecting the heater and cooler!

The maximum pressure of the heat transfer medium must not exceed 1.5 MPa. It is recommended to use ball valves designed to cut the flow of the heat transfer medium of the water heater (cooler) in case of emergency dismantling without releasing the heat transfer medium from the equipment.

The direct and return pipelines must be connected in such a way that the direction of flow of the heating medium is opposite to the air flow (counter-flow connection). This allows for maximum heat exchanger capacity. All technical data for the units are provided for counter-flow connection. In case of a direct-flow connection, the water heat exchanger has lower capacity.

The connection points for the heat transfer medium inlet and outlet are labeled with stickers.

The connection of the heat exchanger to the heat transfer medium supply system must allow for easy disassembly when removing the heat exchanger for maintenance purposes.

Condensate drainage

DX and water coolers are equipped with droplet separators and a drain pan with a drain pipe to allow condensate to drain outside the unit.

The drain pipe must be connected to the condensate drainage system.

Connect the drain pipe, U-trap (not included in the delivery set) and the sewage system with metal, plastic or rubber pipes. The minimum downward slope of the pipes must be 3°.

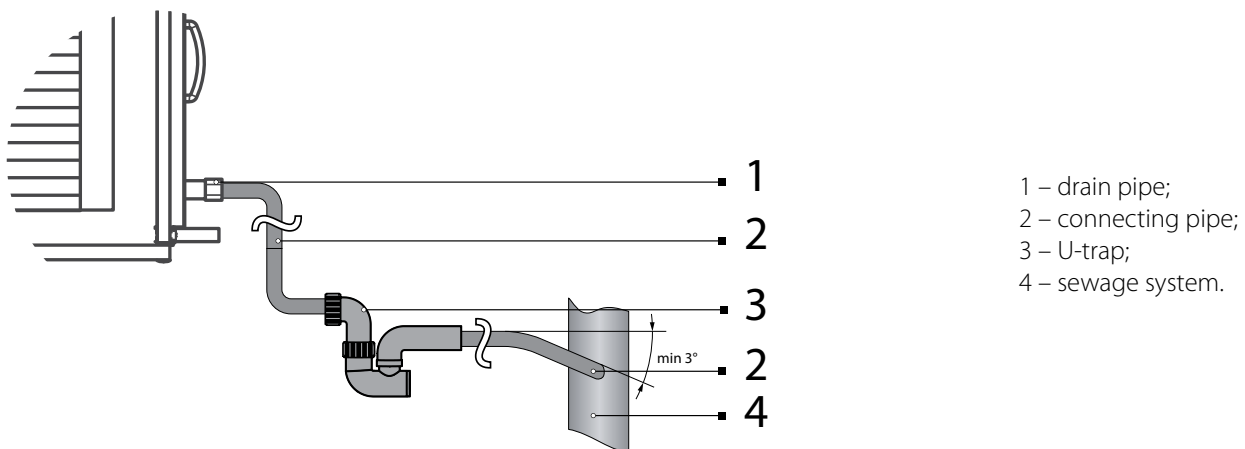

When selecting the U-trap standard size, the total fan pressure must be considered. The U-trap must enable correct function of the ventilation system.

The U-trap diagram and U-trap's minimum dimensions table depending on the air pressure created inside the unit casing are shown below.

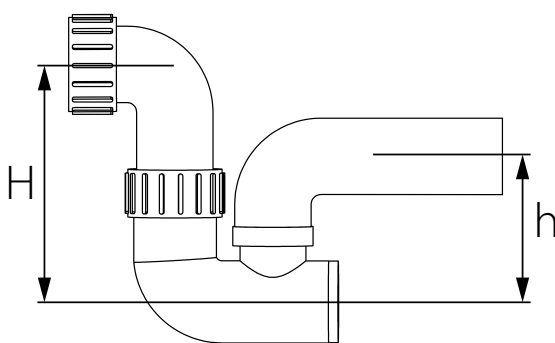

Total fan pressure [Pa]	H [mm]	h [mm]
<600	100	50
600-1000	140	70
1000-1400	190	95
1400-1800	240	120
1800-2200	290	145
2200-2600	340	170

Before starting operation, provide free drainage for the condensed water through the sewage system. Fill up the U-trap with water before using it.

The condensate drainage system is designed for use in premises with ambient temperatures above 0 °C!

If the air temperatures are below 0 °C, the condensate drainage system must be equipped with heat insulation and pre-heating.

Connecting the unit to a ventilation system

The following accessories are used to connect the unit to a ventilation system:

- air flow regulator RRV P
- rectangular flexible joint (rectangular duct compensator) VVG AV
- flange adapter FP

Application of accessories to appropriate dimensions of the units is shown in the table:

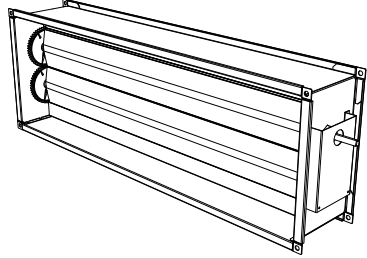
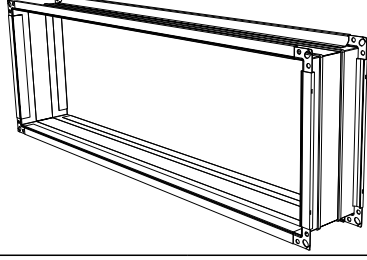
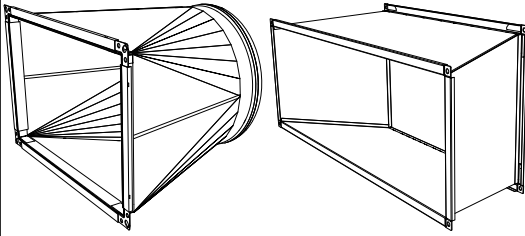
	AV01	AV02	AV04	AV06	
RRV P	RRV P 440x280	RRV P 880x280	RRV P 1370x420	RRV P 1540x560	
VVG AV	VVG AV 440x280	VVG AV 880x280	VVG AV 1370x420	VVG AV 1540x560	
FP	FP 440x280-315	FP 880x280-600x350	FP 1370x420-800x500	FP 1540x560-1000x500	

* The products are not included in the delivery set, must be ordered separately.

CONNECTION TO POWER MAINS

Electrical installation work may only be performed by a qualified specialist who must follow the instructions in this user's manual and take into account the applicable legal and safety regulations.

Before installing the electrical components:



- **Ensure that the unit is switched off.**
- **If the unit has been standing in an unheated room for a long time, make sure that there is no condensation inside the unit and check if the connection contacts and electronic components are not damaged by moisture.**
- **Inspect the insulation of the power cord and other wires for damage.**
- **Find the wiring diagram for the specific unit type.**

Wiring requirements

- If the unit has been standing in an unheated room for a long time, make sure that there is no condensation inside the unit and check if the connection contacts and electronic components are not damaged by moisture.
- Inspect the insulation of the power cord and other wires for damage.
- Find the wiring diagram for the specific unit type.
- Only plug the unit into a functioning electrical outlet with a protective grounding connection that meets the electrical safety requirements. The grounding must be installed in accordance with the EN61557, BS 7671 standards.
- It is recommended to route control signal cables at a distance of at least 20 cm from power cables to reduce the possibility of electrical interference.
- All external electrical components must be connected in strict accordance with the wiring diagram.
- Do not disconnect connectors by pulling on wires or cables.

Connect to the power mains according to the diagrams presented in the "Automation" section

The cross-section of the power cables is shown in the table below.

Ventilation unit model	Power cable		
	Controller board	Integrated preheater	Reheater
AV01 UVU 1000 ... A30/31/32	5 x 2.5 mm ² (Cu)	-	4 x 2.5 mm ² (Cu)
AV02 UVU 2000 ... A30/31/32	5 x 6 mm ² (Cu)	-	4 x 4 mm ² (Cu)
AV04 UVU 4000 ... A30/31/32	3 x 1.5 mm ² (Cu)	4 x 16 mm ² (Cu)	4 x 16 mm ² (Cu)
AV06 UVU 6000 ... A30/31/32	5 x 2.5 mm ² (Cu)	4 x 16 mm ² (Cu)	4 x 16 mm ² (Cu)
AV06 UVU 8000 ... A30/31/32	5 x 2.5 mm ² (Cu)	4 x 35 mm ² (Cu)	4 x 35 mm ² (Cu)

Installation of inline temperature sensor

Installation of the air temperature sensor necessary to control the operation of heaters and coolers.

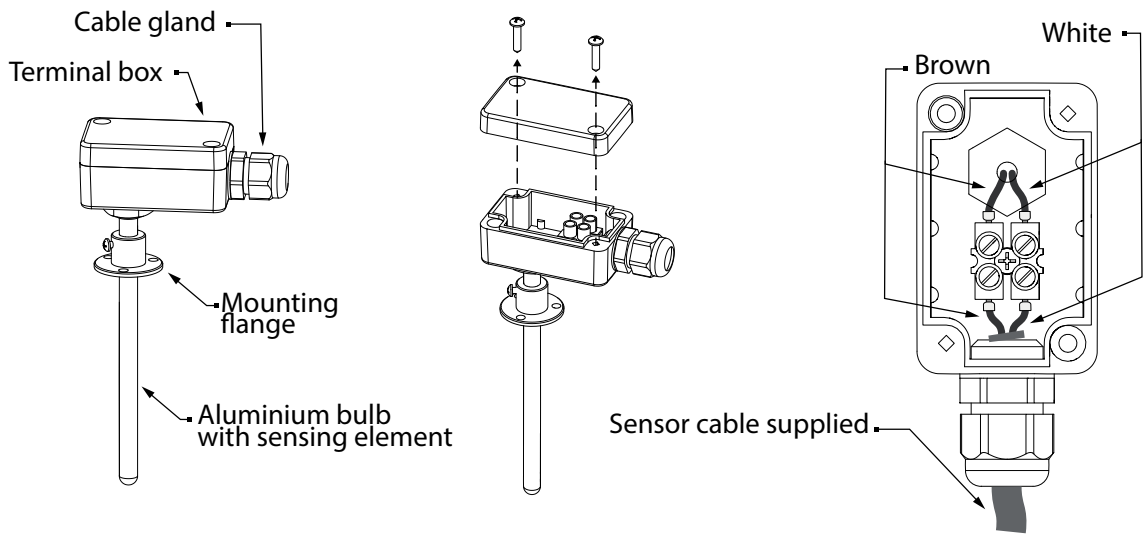

To ensure the most accurate temperature measurement, the supply air sensor must be installed in the indoor supply air duct, downstream of all heating/cooling elements, at a distance of at least two duct diameters from the nearest heat exchanger or from the outermost element of the ventilation system.

The outdoor air temperature sensor must be installed in the outdoor air duct, at a distance of at least two air duct diameters from the outermost element of the ventilation system.

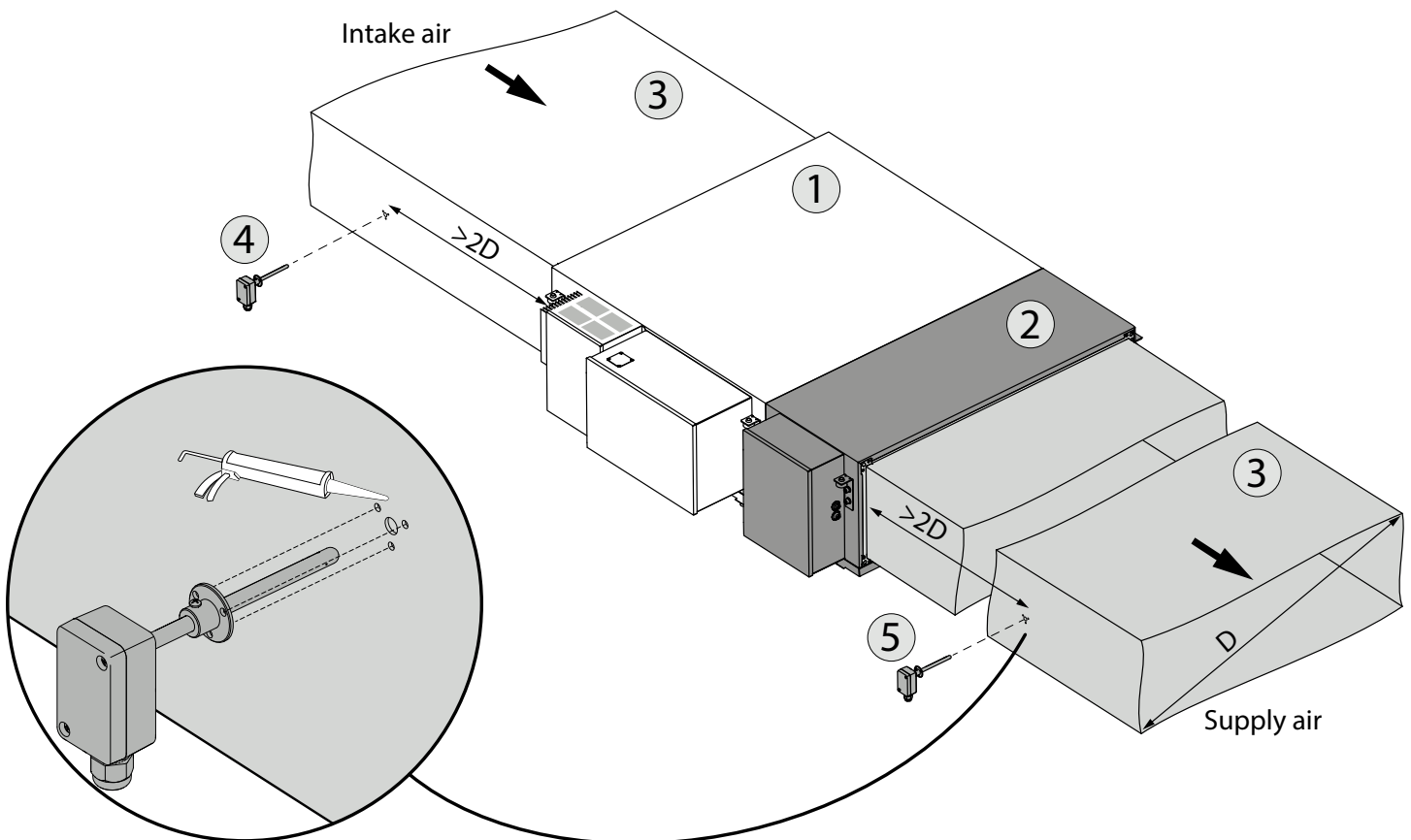

1 — Ventilation unit; 2 — Reheater; 3 — Rectangular air duct;
4 — Inline outdoor air temperature sensor; 5 — Inline supply air temperature sensor.

AUTOMATION

Automation included in the delivery set is an inseparable part of each ventilation and air conditioning unit, which enables the possibility of smooth control and long and trouble-free operation, preventing operation faults and severe alarms.

In addition to the automation unit, other elements may be included: air damper actuators, pressure, temperature, humidity, CO₂ and air flow sensors, humidifiers and triac controllers. User manuals for these accessories are not provided with this manual.

AV01 UVU 1000 ... A30/31/32

The basic layout of an AV01 UVU 1000 ... A30/31/32 controller board with the cover removed is shown below (ID for ordering 0688476720)

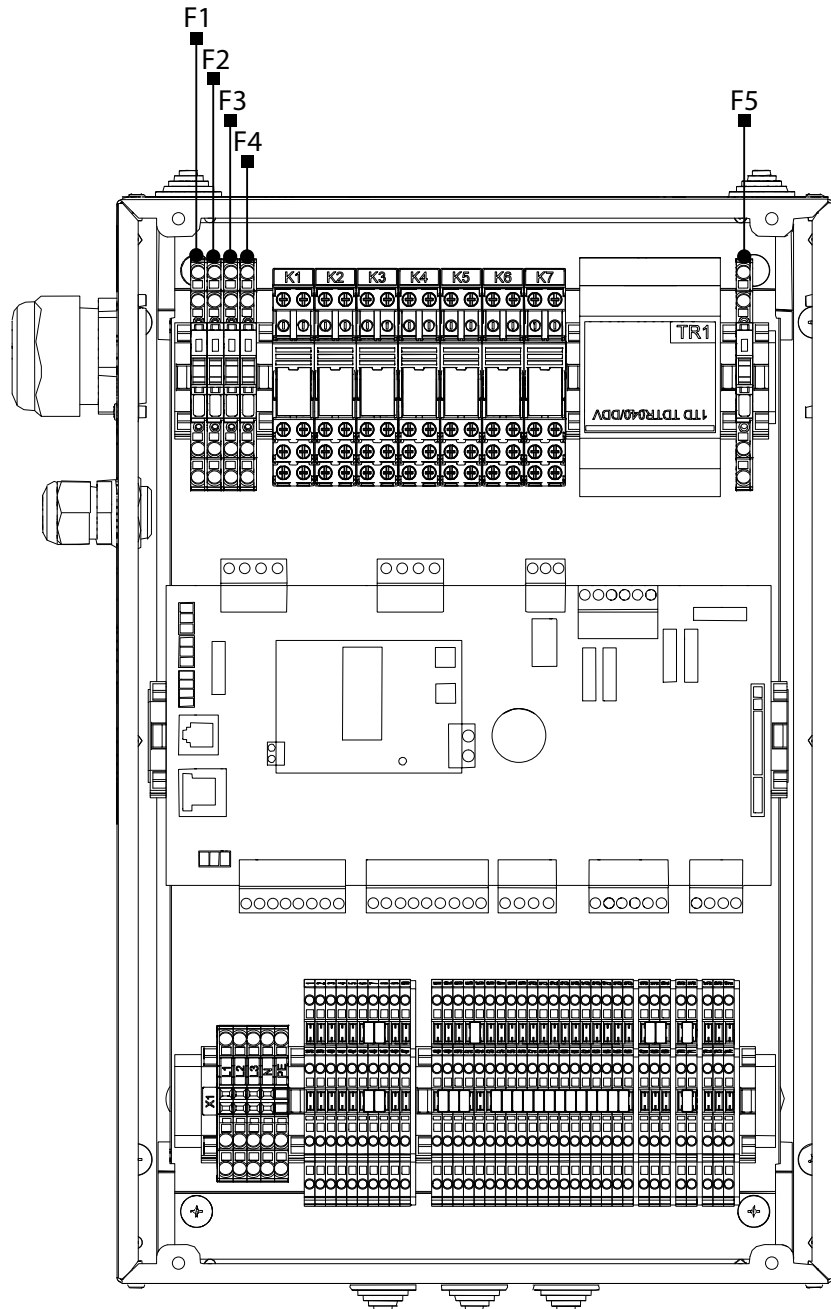

Designation of switches

Designation	Function	Value
F1	Power supply protection of the supply fan	3.15A
F2	Power supply protection of the heating circulation pump and temperature controller	3.15A
F3	Power supply protection of the cooling circulation pump and the control board of the CCU	5A
F4	Power supply protection of the 230 VAC digital outputs and actuators	5A
F5	Power supply protection of the 24 VAC controller, sensors and actuators	3.15A

Replacement table of circuit breakers for their analogs for power supply protection of the supply air fan

Rated current [A]	3.15		
Manufacturing factory	LITTELFUSE	EATON/BUSSMANN	ESKA
Equipment code	02183.15MXP	BK1-S506-3-15-R	522.522
Breaking current	35A		
Circuit breaker size	5x20mm		
Circ. breaker characteristic	Slow		

Replacement table of circuit breakers and their analogs for heating circulation pump and temperature controller power supply

Rated current [A]	3.15		
Manufacturing factory	LITTELFUSE	EATON/BUSSMANN	ESKA
Equipment code	02183.15MXP	BK1-S506-3-15-R	522.522
Breaking current	35A		
Circuit breaker size	5x20mm		
Circ. breaker characteristic	Slow		

Replacement table of circuit breakers and their analogs for 24 VAC controller, sensors and actuators power supply

Rated current [A]	3.15		
Manufacturing factory	LITTELFUSE	EATON/BUSSMANN	ESKA
Equipment code	02183.15MXP	BK1-S506-3-15-R	522.522
Breaking current	35A		
Circuit breaker size	5x20mm		
Circ. breaker characteristic	Slow		

Replacement table of circuit breakers and their analogs for power supply protection of cooling circulation pump and the control board of the CCU

Rated current [A]	5		
Manufacturing factory	LITTELFUSE	EATON/BUSSMANN	ESKA
Equipment code	0218005.MXP	BK1-S506-5-R	522.524
Breaking current	35A		
Circuit breaker size	5x20mm		
Circ. breaker characteristic	Slow		

Replacement table of circuit breakers for their analogs for protecting digital outputs' and 230 VAC actuators' power supply

Rated current [A]	5		
Manufacturing factory	LITTELFUSE	EATON/BUSSMANN	ESKA
Equipment code	0218005.MXP	BK1-S506-5-R	522.524
Breaking current	35A		
Circuit breaker size	5x20mm		

External wiring diagram

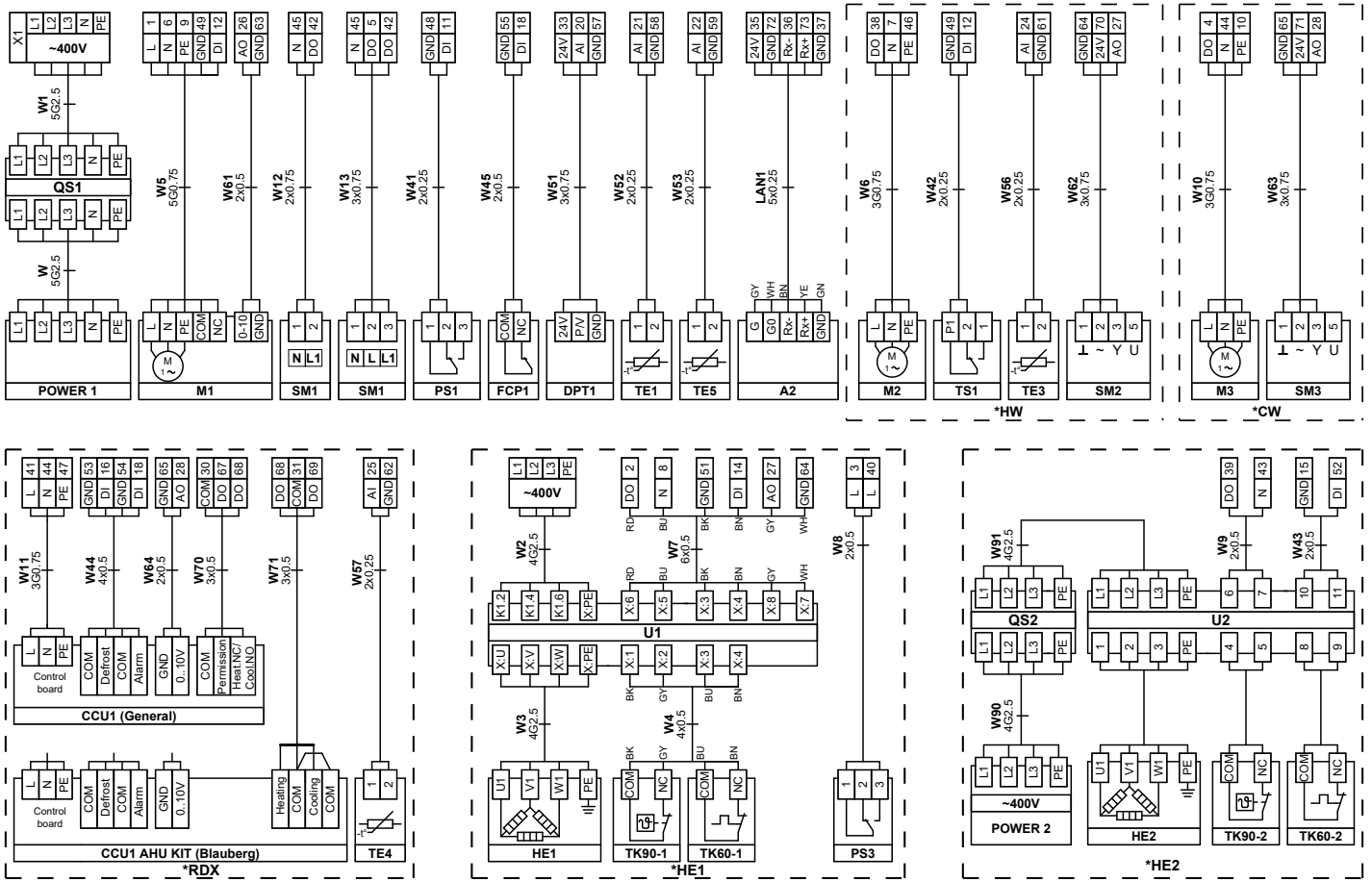

* Connect devices based on the order

** If the additional heating section HE2 is absent, install the jumper between the terminals 15 and 52

General equipment	
Designation	Name
A2	Control terminal
DPT1	Supply air pressure (VAV/CAV)
FCP1	Fire alarm (customer's equipment)
M1	Supply fan
POWER1	Power supply from the customer's feeder 25A
PS1	Fresh air filter differential pressure switch
SM1	Fresh air damper actuator
TE1	Intake air temperature
TE5	Temperature in the supply air duct
QS1	Load-break 25A (customer's equipment)

Equipment is based on the order	
Designation	Name
Water heating (HW) section	
M2	Heating circulation pump
SM2	Three-way heating valve actuator
TE3	Heating temperature of the back water flow
TS1	Water heater frost protection
Water cooling (CW) section	
M3	Cooling circulation pump
SM3	Three-way cooling valve actuator
DX reverse heat exchanger (RDX) section	
CCU1	Compressor and condenser unit
TE4	Temperature upstream the compressor and condenser unit
9 kW electric heating (HE1) section	
PS3	Supply fan differential pressure switch (heating protection)
TK60-1	Self-resetting thermal switch 60°C.
TK90-1	Button-driven thermal switch 90°C
U1	Heating temperature control board 9 kW
Additional electric heating section 9 kW (HE2)	
POWER 2	Power supply from the customer's feeder 32A
QS2	Load-break 25A (customer's equipment)
TK60-2	Self-resetting thermal switch 60°C.
TK90-2	Button-driven thermal switch 90°C
U2	DOL heater starting control board 9 kW

The basic layout of a 9 kW AV01 UVU 1000-RE-HE009 DOL starting controller board with the cover removed is shown below (ID for ordering 0688476819)

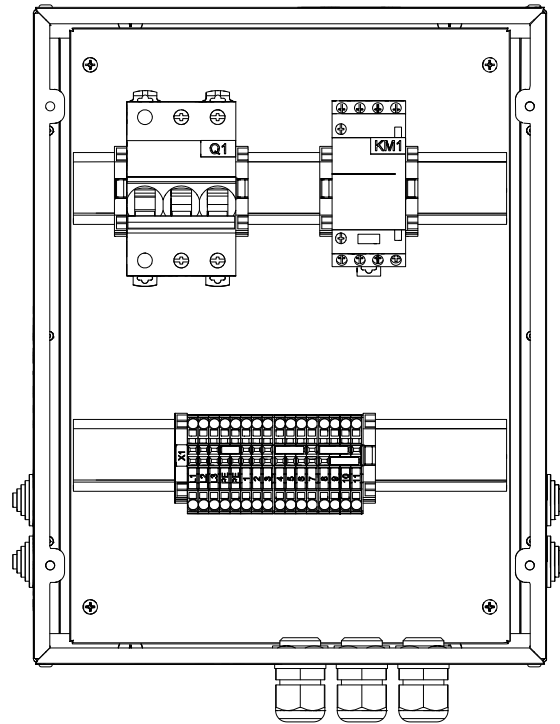

Designation of switches

Designation	Function	Value
Q1	Power supply protection of group of electric heating elements 9 kW	25A

External wiring diagram

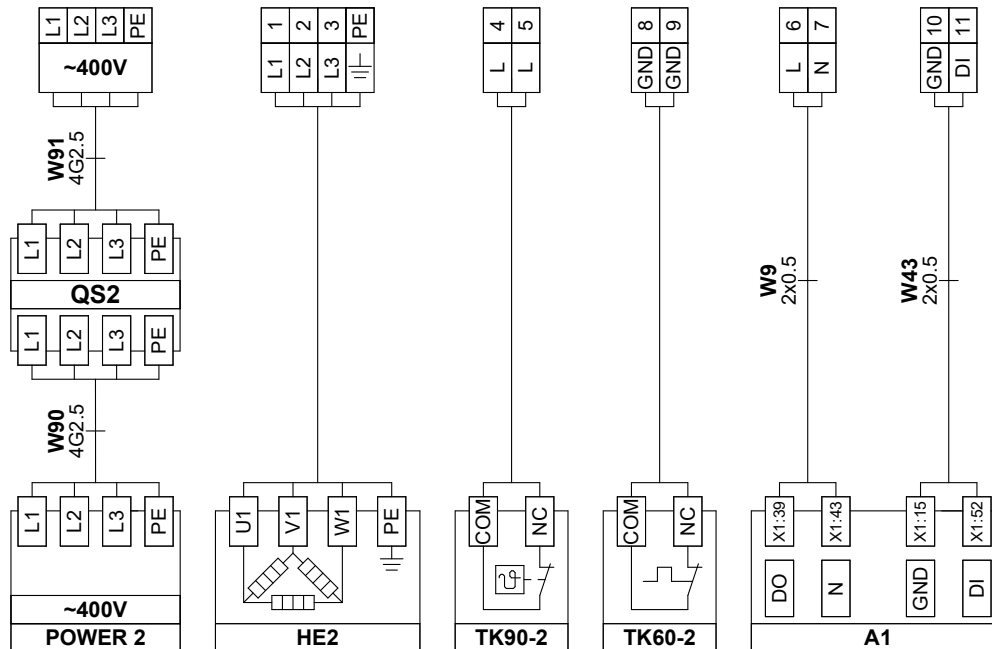

Designation	Name
A1	Controller board
HE2	Additional electric heating section 9 kW (HE2)
POWER 2	Power supply from the customer's feeder 32A
QS2	Load-break 25A (customer's equipment)
TK60-2	Self-resetting thermal switch 60°C.
TK90-2	Button-driven thermal switch 90°C

AV02 UVU 2000 ... A30/31/32

The basic layout of an AV02 UVU 2000 controller board with the cover removed is shown below (ID for ordering 0688476916)

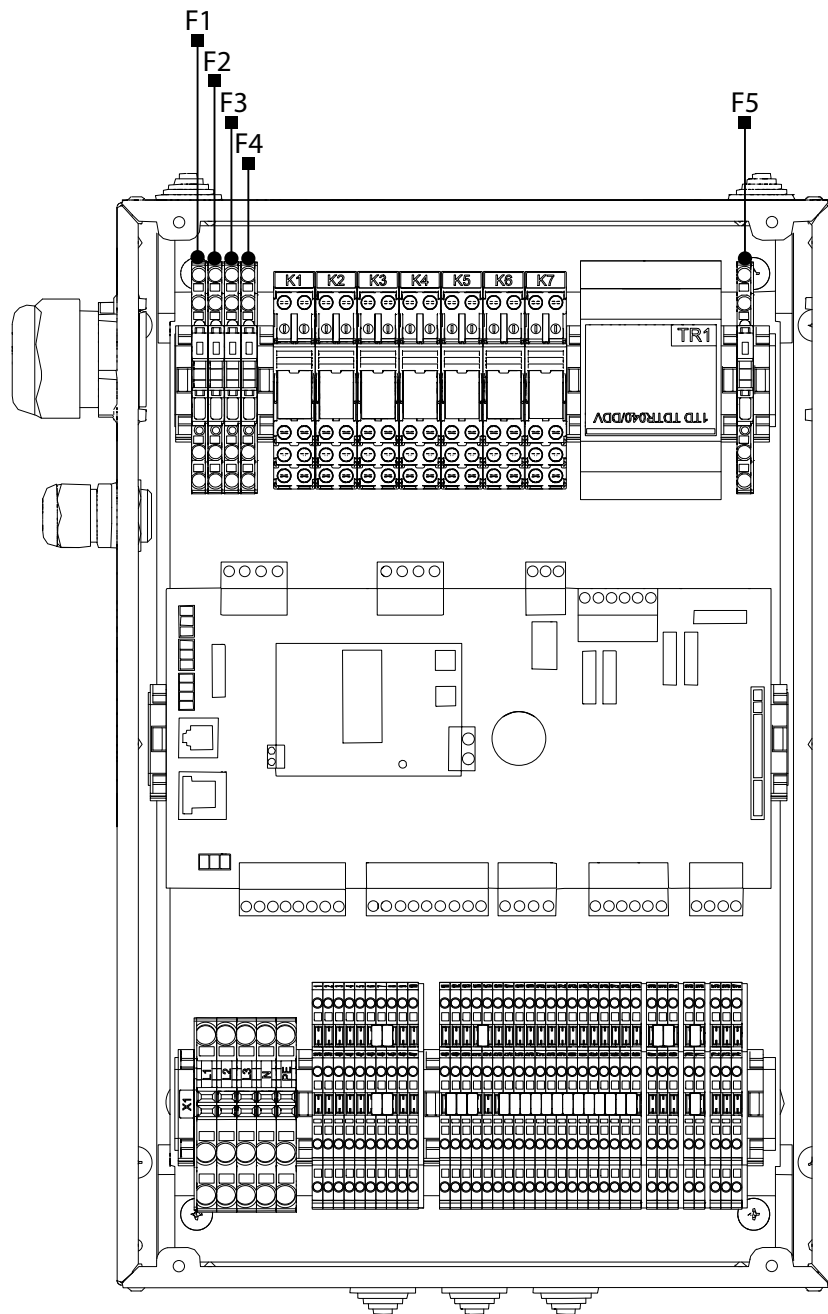

Designation of switches

Designation	Function	Value
F1	Power supply protection of the supply fan	3.15A
F2	Power supply protection of the heating circulation pump and temperature controller	3.15A
F3	Power supply protection of the cooling circulation pump and the control board of the CCU	5A
F4	Power supply protection of the 230 VAC digital outputs and actuators	5A
F5	Power supply protection of the 24 VAC controller, sensors and actuators	3.15A

Replacement table of circuit breakers for their analogs for power supply protection of the supply air fan

Rated current [A]	3.15		
Manufacturing factory	LITTELFUSE	EATON/BUSSMANN	ESKA
Equipment code	02183.15MXP	BK1-S506-3-15-R	522.522
Breaking current	35A		
Circuit breaker size	5x20mm		
Circ. breaker characteristic	Slow		

Replacement table of circuit breakers and their analogs for heating circulation pump and temperature controller power supply

Rated current [A]	3.15		
Manufacturing factory	LITTELFUSE	EATON/BUSSMANN	ESKA
Equipment code	02183.15MXP	BK1-S506-3-15-R	522.522
Breaking current	35A		
Circuit breaker size	5x20mm		
Circ. breaker characteristic	Slow		

Replacement table of circuit breakers and their analogs for 24 VAC controller, sensors and actuators power supply

Rated current [A]	3.15		
Manufacturing factory	LITTELFUSE	EATON/BUSSMANN	ESKA
Equipment code	02183.15MXP	BK1-S506-3-15-R	522.522
Breaking current	35A		
Circuit breaker size	5x20mm		
Circ. breaker characteristic	Slow		

Replacement table of circuit breakers and their analogs for power supply protection of cooling circulation pump and the control board of the CCU

Rated current [A]	5		
Manufacturing factory	LITTELFUSE	EATON/BUSSMANN	ESKA
Equipment code	0218005.MXP	BK1-S506-5-R	522.524
Breaking current	35A		
Circuit breaker size	5x20mm		
Circ. breaker characteristic	Slow		

Replacement table of circuit breakers for their analogs for protecting digital outputs' and 230 VAC actuators' power supply

Rated current [A]	5		
Manufacturing factory	LITTELFUSE	EATON/BUSSMANN	ESKA
Equipment code	0218005.MXP	BK1-S506-5-R	522.524
Breaking current	35A		
Circuit breaker size	5x20mm		

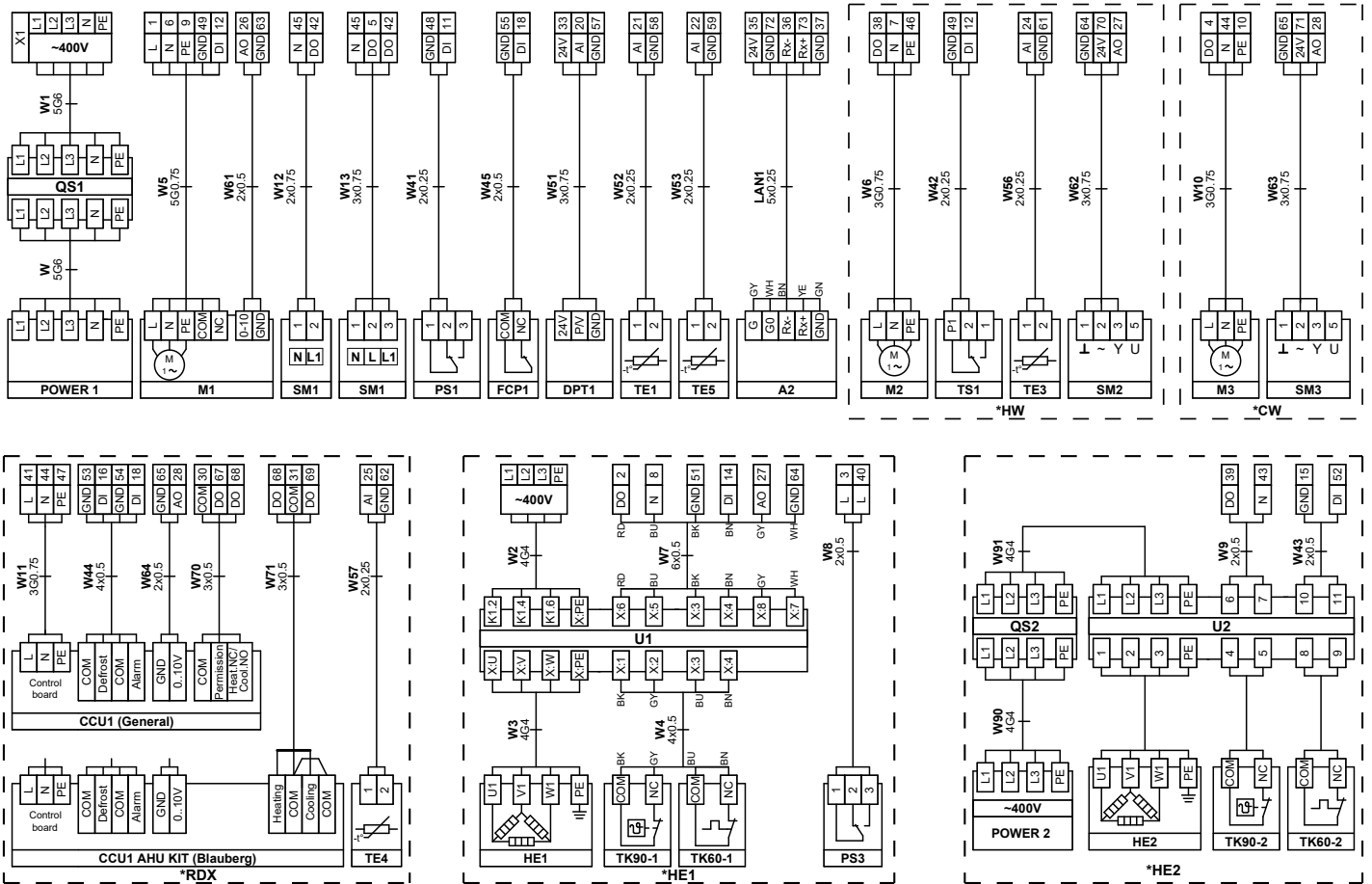
External wiring diagram

* Connect devices based on the order

** If the additional heating section HE2 is absent, install the jumper between the terminals 15 and 52

General equipment	
Designation	Name
A2	Control terminal
DPT1	Supply air pressure (VAV/CAV)
FCP1	Fire alarm (customer's equipment)
M1	Supply fan
POWER1	Power supply from the customer's feeder 40A
PS1	Fresh air filter differential pressure switch
SM1	Fresh air damper actuator
TE1	Intake air temperature
TE5	Temperature in the supply air duct
QS1	Load-break 40A (customer's equipment)

Equipment is based on the order	
Designation	Name
Water heating (HW) section	
M2	Heating circulation pump
SM2	Three-way heating valve actuator
TE3	Heating temperature of the back water flow
TS1	Water heater frost protection
Water cooling section (CW)	
M3	Cooling circulation pump
SM3	Three-way cooling valve actuator
DX reverse heat exchanger (RDX) section	
CCU1	Compressor and condenser unit
TE4	Temperature upstream the compressor and condenser unit
18 kW electric heating (HE1) section	
PS3	Supply fan differential pressure switch (heating protection)
TK60-1	Self-resetting thermal switch 60°C.
TK90-1	Button-driven thermal switch 90°C
U1	Heating temperature control board 18 kW
Additional electric heating section 18 kW(HE2)	
POWER 2	Power supply from the customer's feeder 40A
QS2	Load-break 32A (customer's equipment)
TK60-2	Self-resetting thermal switch 60°C.
TK90-2	Button-driven thermal switch 90°C
U2	DOL heater starting control board 18 kW

The basic layout of a 18 kW AV02 UVU 2000-RE-HE018 DOL starting controller board with the cover removed is shown below (ID for ordering 0688476984)

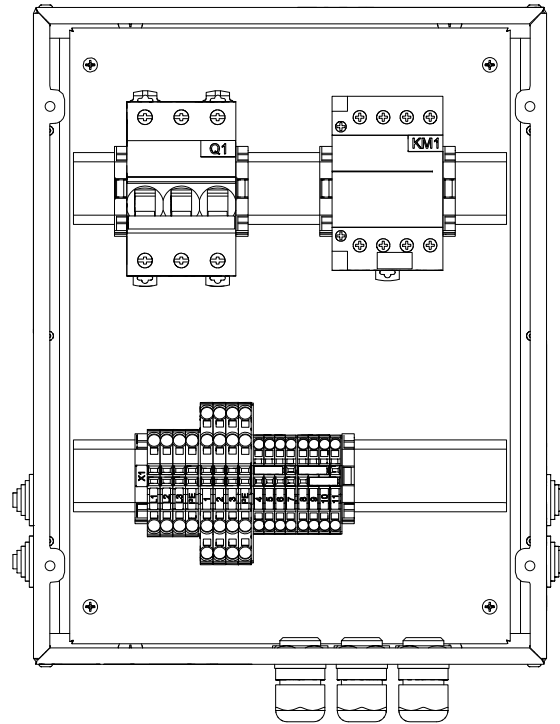

Designation of switches

Designation	Function	Value
Q1	Power supply protection of group of electric heating elements 18 kW	35A

External wiring diagram

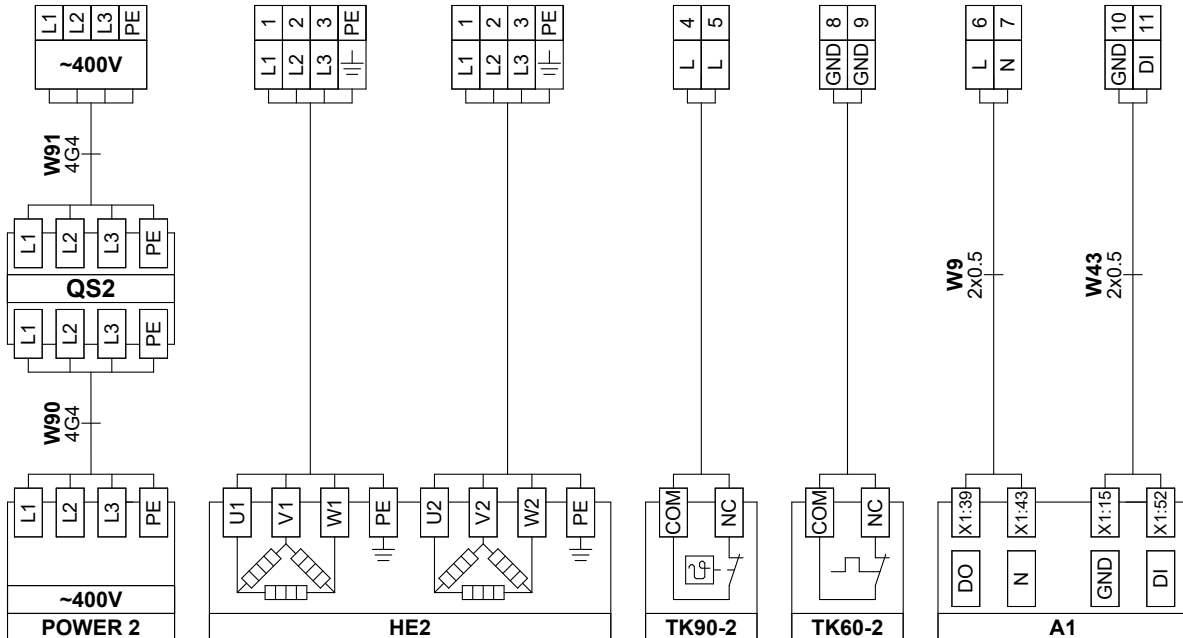

Designation	Name
A1	Controller board
HE2	Additional electric heating section 18 kW(HE2)
POWER 2	Power supply from the customer's feeder 40A
QS2	Load-break 32A (customer's equipment)
TK60-2	Self-resetting thermal switch 60°C.
TK90-2	Button-driven thermal switch 90°C

AV04 UVU 4000 ... A30/31/32

The basic layout of an AV04 UVU 4000 2x (1PEC) controller board with the cover removed is shown below (ID for ordering 0688475907)

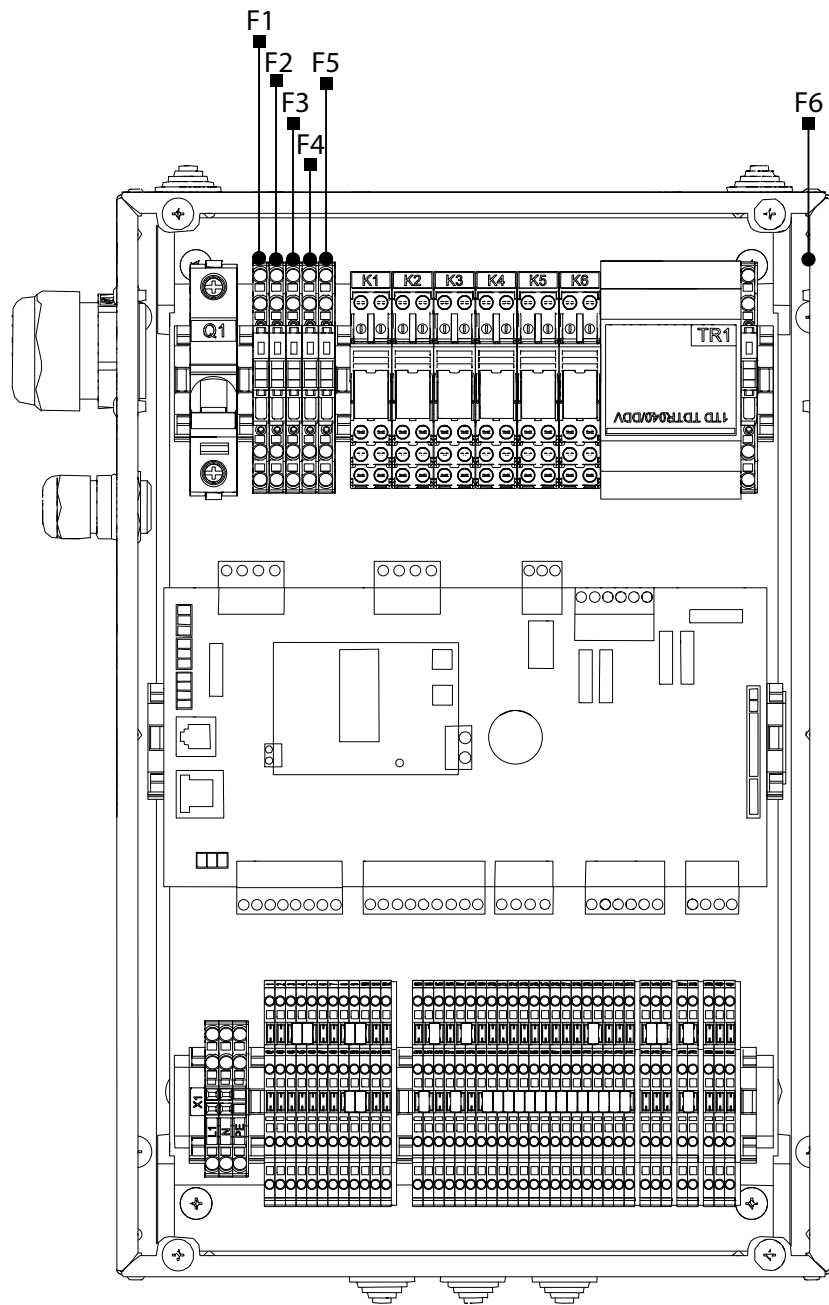

Designation of switches

Designation	Function	Value
F1	Power supply protection of the M1 supply fan	4A
F2	Power supply protection of the M2 supply fan	4A
F3	Power supply protection of the heating circulation pump and temperature controller	5A
F4	Power supply protection of the cooling circulation pump and the control board of the CCU	5A
F5	Power supply protection of the 230 VAC digital outputs and actuators	5A
F6	Power supply protection of the 24 VAC controller, sensors and actuators	3.15A
Q1	Control panel protection (main circuit breaker)	16A

Replacement table of circuit breakers for their analogs for power supply protection of the supply air fan

Rated current [A]	4		
Manufacturing factory	LITTELFUSE	EATON/BUSSMANN	ESKA
Equipment code	0218004.MXP	BK1-S506-4-R	522.523
Breaking current	40A		
Circuit breaker size	5x20mm		
Circ. breaker characteristic	Slow		

Replacement table of circuit breakers and their analogs for heating circulation pump and temperature controller power supply

Rated current [A]	5		
Manufacturing factory	LITTELFUSE	EATON/BUSSMANN	ESKA
Equipment code	0218005.MXP	BK1-S506-5-R	522.524
Breaking current	35A		
Circuit breaker size	5x20mm		
Circ. breaker characteristic	Slow		

Replacement table of circuit breakers and their analogs for 24 VAC controller, sensors and actuators power supply

Rated current [A]	3.15		
Manufacturing factory	LITTELFUSE	EATON/BUSSMANN	ESKA
Equipment code	02183.15MXP	BK1-S506-3-15-R	522.522
Breaking current	35A		
Circuit breaker size	5x20mm		
Circ. breaker characteristic	Slow		

Replacement table of circuit breakers and their analogs for power supply protection of cooling circulation pump and the control board of the CCU

Rated current [A]	5		
Manufacturing factory	LITTELFUSE	EATON/BUSSMANN	ESKA
Equipment code	0218005.MXP	BK1-S506-5-R	522.524
Breaking current	35A		
Circuit breaker size	5x20mm		
Circ. breaker characteristic	Slow		

Replacement table of circuit breakers for their analogs for protecting digital outputs' and 230 VAC actuators' power supply

Rated current [A]	5		
Manufacturing factory	LITTELFUSE	EATON/BUSSMANN	ESKA
Equipment code	0218005.MXP	BK1-S506-5-R	522.524
Breaking current	35A		
Circuit breaker size	5x20mm		

External wiring diagram

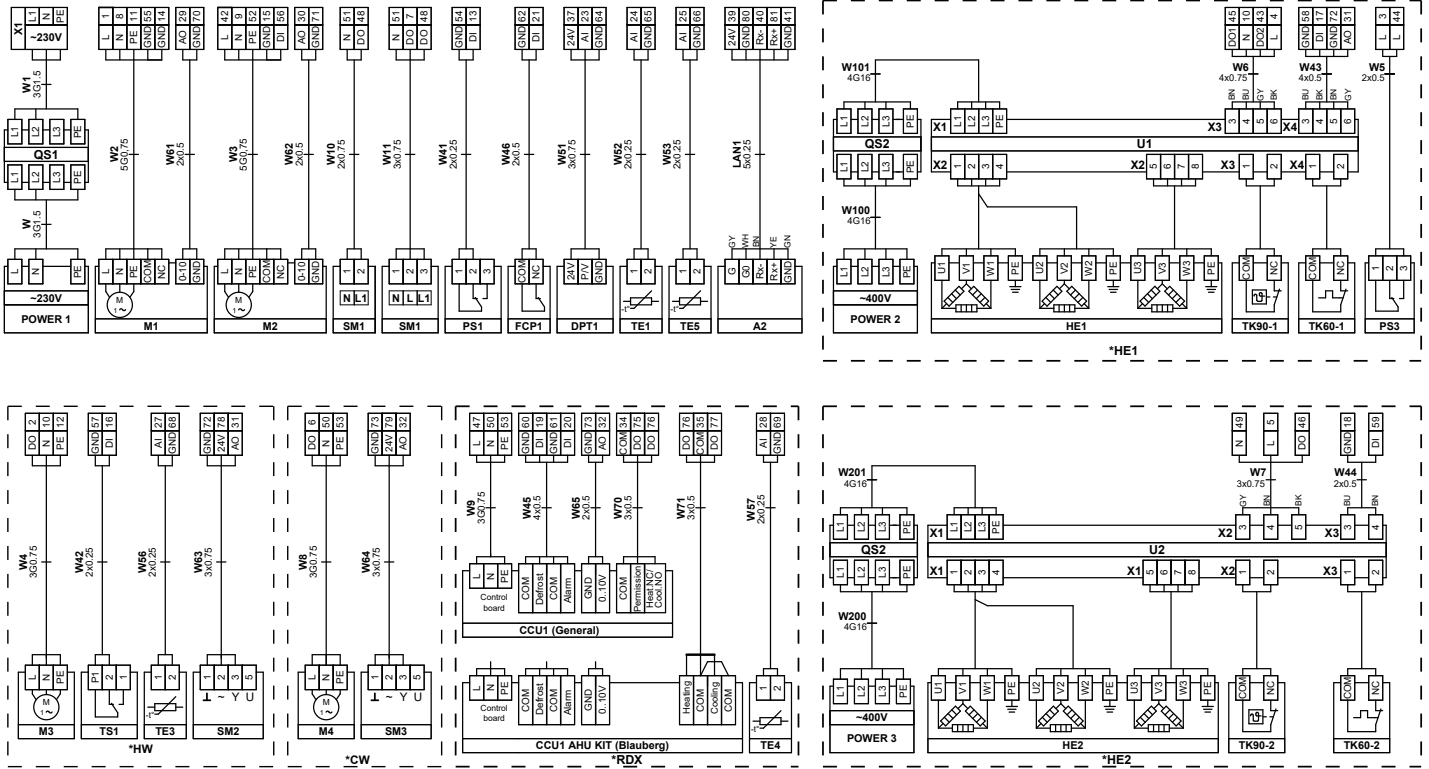

* Connect devices based on the order

** If the additional heating section HE2 is absent, install the jumper between the terminals 18 and 59

General equipment	
Designation	Name
A2	Control terminal
DPT1	Supply air pressure (VAV/CAV)
FCP1	Fire alarm (customer's equipment)
M1	Supply fan
POWER1	Power supply from the customer's feeder 20A
PS1	Fresh air filter differential pressure switch
SM1	Fresh air damper actuator
TE1	Intake air temperature
TE5	Temperature in the supply air duct
QS1	Load-break 16A (customer's equipment)

* Equipment is based on the order	
Designation	Name
Water heating (HW) section	
M2	Heating circulation pump
SM2	Three-way heating valve actuator
TE3	Heating temperature of the back water flow
TS1	Water heater frost protection
Water cooling (CW) section	
M3	Cooling circulation pump
SM3	Three-way cooling valve actuator
DX reverse heat exchanger (RDX) section	
CCU1	Compressor and condenser unit
TE4	Temperature upstream the compressor and condenser unit
36 kW electric heating (HE1) section	
PS3	Supply fan differential pressure switch (heating protection)
POWER 2	Power supply from the customer's feeder 63A
QS2	Load-break 63A (customer's equipment)
TK60-1	Self-resetting thermal switch 60°C.
TK90-1	Button-driven thermal switch 90°C
U1	Heating temperature control board 36 kW
Additional electric heating section 36 kW (HE2)	
POWER 3	Power supply from the customer's feeder 63A
QS3	Load-break 63A (customer's equipment)
TK60-2	Self-resetting thermal switch 60°C.
TK90-2	Button-driven thermal switch 90°C
U2	DOL heater starting control board 36 kW

The basic layout of an AV04 UVU 4000-PRE-HE036 heating temperature control board 36 kW with the cover removed is shown below (ID for ordering 0688475708)

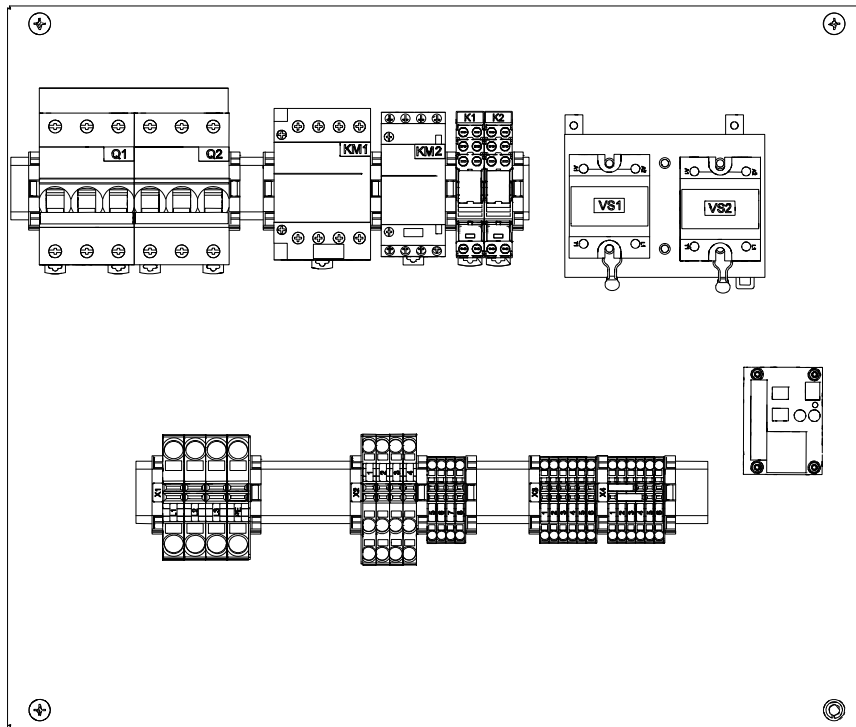

Designation of switches

Designation	Function	Value
Q1	Power supply protection of group of electric heating elements 24 kW	40A
Q2	Power supply protection of group of electric heating elements 12 kW	25A

External wiring diagram

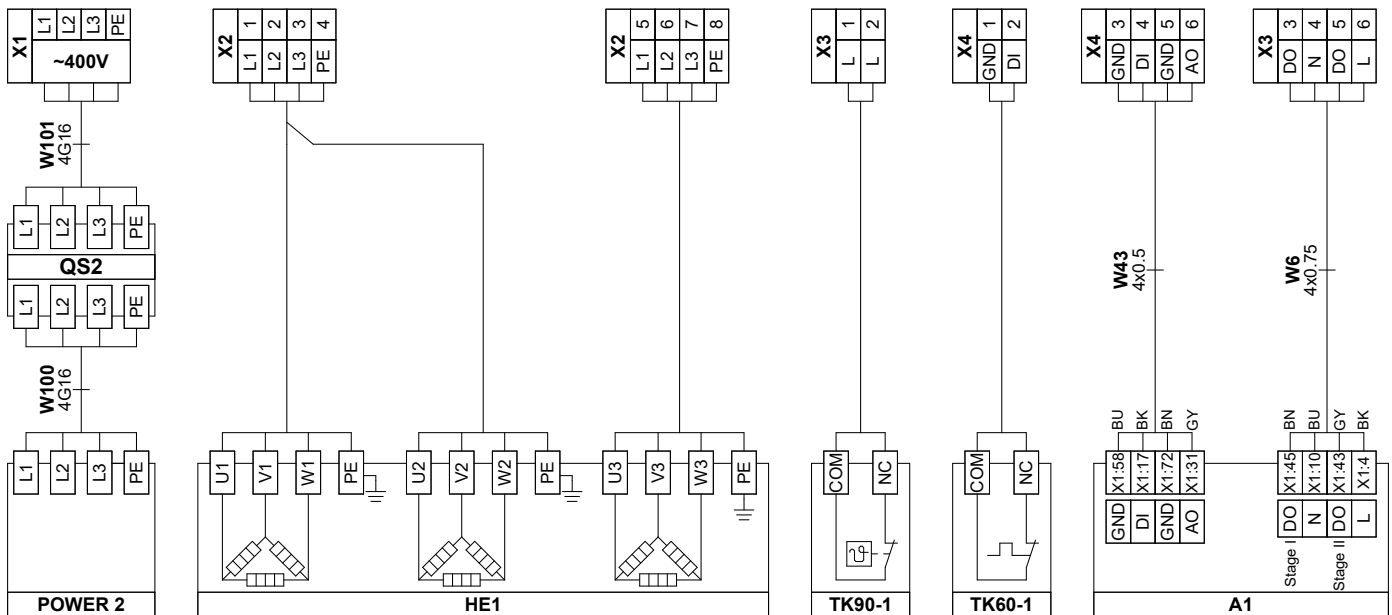

Designation	Name
A1	Controller board
HE1	36 kW electric heating section
POWER 2	Power supply from the customer's feeder 63A
QS2	Load-break 63A (customer's equipment)
TK60-1	Self-resetting thermal switch 60°C.
TK90-1	Button-driven thermal switch 90°C

The basic layout of an AV04 UVU 4000-RE-HE036 DOL starting controller board 36 kW with the cover removed is shown below (ID for ordering 0688477050)

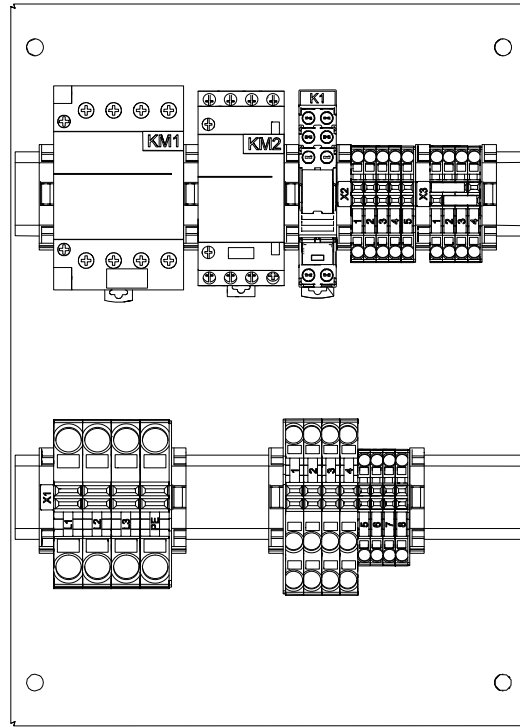

External wiring diagram

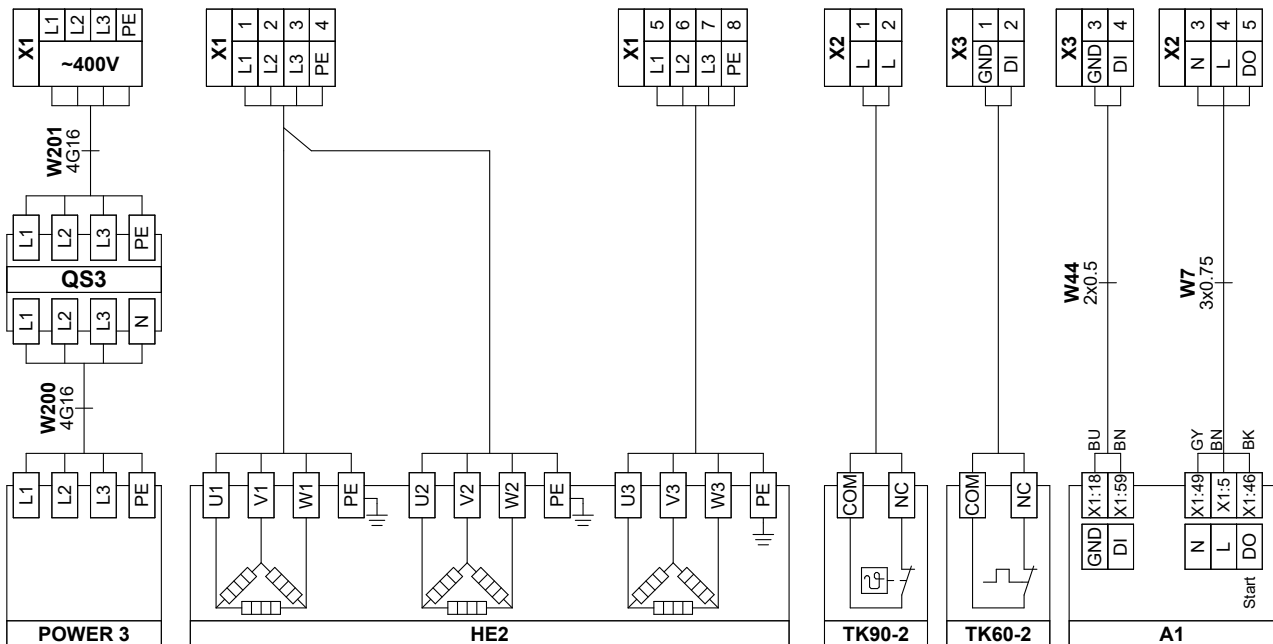

Designation	Name
A1	Controller board
HE2	Additional electric heating section 36 kW
POWER 3	Power supply from the customer's feeder 63A
QS3	Load-break 63A (customer's equipment)
TK60-2	Self-resetting thermal switch 60°C.
TK90-2	Button-driven thermal switch 90°C

AV06 UVU 6000 ... A30/31/32

The basic layout of an AV06 UVU 6000 2x (3PEC) controller board with the cover removed is shown below (ID for ordering 0688475527)

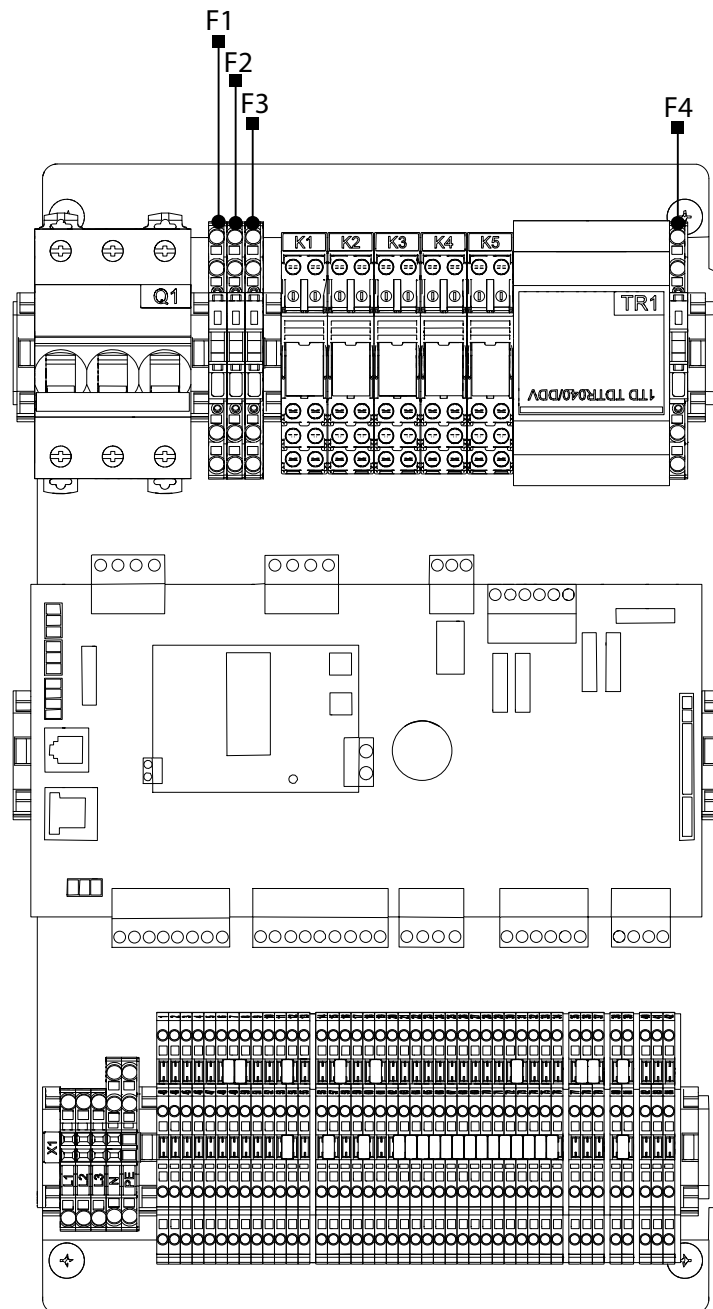

Designation of switches

Designation	Function	Value
F1	Power supply protection of the heating circulation pump	5A
F2	Power supply protection of the cooling circulation pump and the control board of the CCU	5A
F3	Power supply protection of the 230 VAC digital outputs and actuators	5A
F4	Power supply protection of the 24 VAC controller, sensors and actuators	3.15A
Q1	Power supply protection of the supply fans	6A

Replacement table of circuit breakers for their analogs for heating circulation pump power supply protection

Rated current [A]	5		
Manufacturing factory	LITTELFUSE	EATON/BUSSMANN	ESKA
Equipment code	0218005.MXP	BK1-S506-5-R	522.524
Breaking current	35A		
Circuit breaker size	5x20mm		
Circ. breaker characteristic	Slow		

Replacement table of circuit breakers and their analogs for 24 VAC controller, sensors and actuators power supply

Rated current [A]	3.15		
Manufacturing factory	LITTELFUSE	EATON/BUSSMANN	ESKA
Equipment code	02183.15MXP	BK1-S506-3-15-R	522.522
Breaking current	35A		
Circuit breaker size	5x20mm		
Circ. breaker characteristic	Slow		

Replacement table of circuit breakers and their analogs for power supply protection of cooling circulation pump and the control board of the CCU

Rated current [A]	5		
Manufacturing factory	LITTELFUSE	EATON/BUSSMANN	ESKA
Equipment code	0218005.MXP	BK1-S506-5-R	522.524
Breaking current	35A		
Circuit breaker size	5x20mm		
Circ. breaker characteristic	Slow		

Replacement table of circuit breakers for their analogs for protecting digital outputs' and 230 VAC actuators' power supply

Rated current [A]	5		
Manufacturing factory	LITTELFUSE	EATON/BUSSMANN	ESKA
Equipment code	0218005.MXP	BK1-S506-5-R	522.524
Breaking current	35A		
Circuit breaker size	5x20mm		
Circ. breaker characteristic	Slow		

External wiring diagram

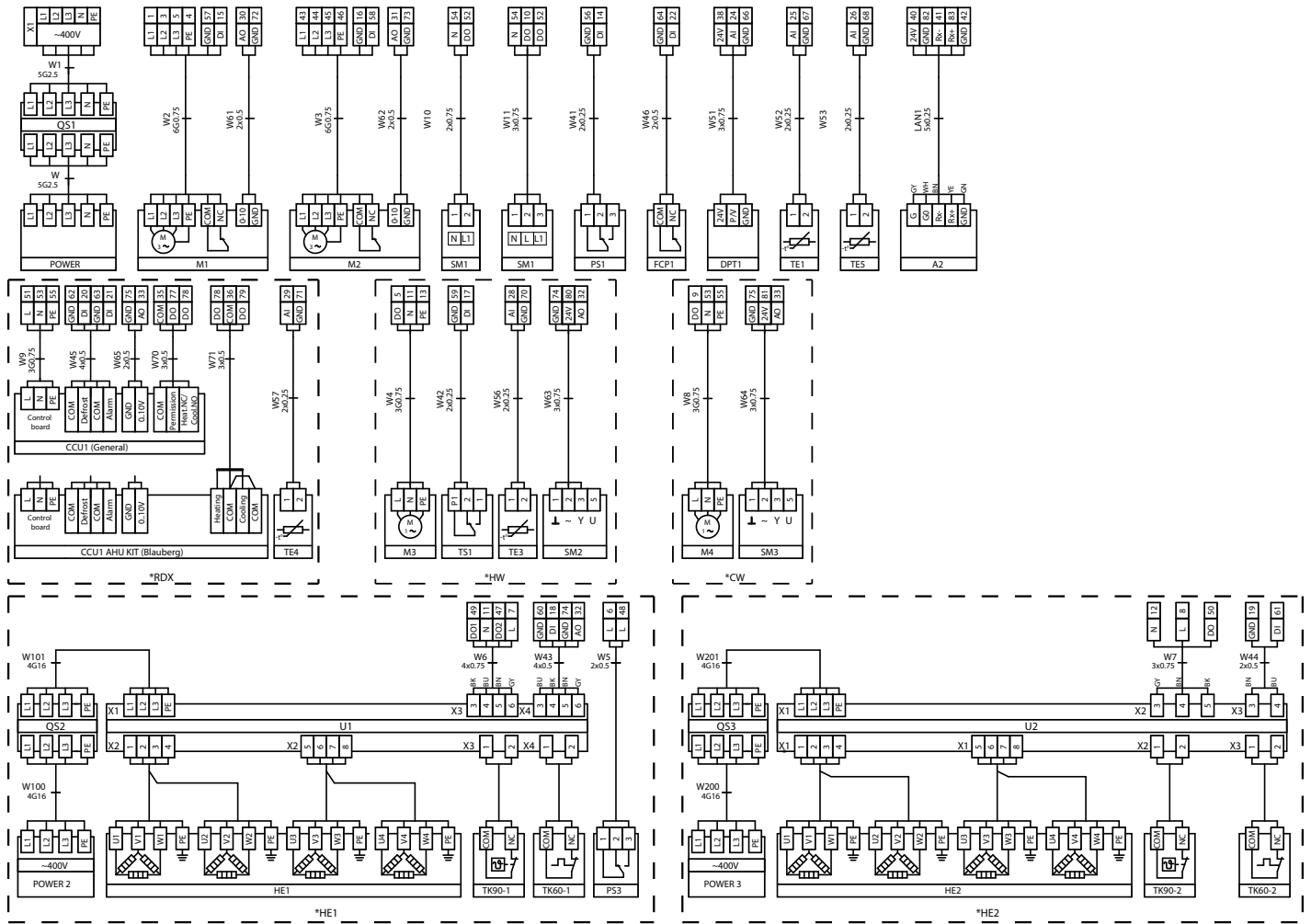

* Connect devices based on the order

** If the additional heating section HE2 is absent, install the jumper between the terminals 19 and 61

General equipment	
Designation	Name
A2	Control terminal
DPT1	Supply air pressure (VAV/CAV)
FCP1	Fire alarm (customer's equipment)
M1	Supply fan
POWER1	Power supply from the customer's feeder 25A
PS1	Fresh air filter differential pressure switch
SM1	Fresh air damper actuator
TE1	Intake air temperature
TE5	Temperature in the supply air duct
QS1	Load-break 25A (customer's equipment)

* Equipment is based on the order	
Designation	Name
Water heating (HW) section	
M2	Heating circulation pump
SM2	Three-way heating valve actuator
TE3	Heating temperature of the back water flow
TS1	Water heater frost protection
Water cooling section (CW)	
M3	Cooling circulation pump
SM3	Three-way cooling valve actuator
DX reverse heat exchanger (RDX) section	
CCU1	Compressor and condenser unit
TE4	Temperature upstream the compressor and condenser unit
48 kW electric heating (HE1) section	
PS3	Supply fan differential pressure switch (heating protection)
POWER 2	Power supply from the customer's feeder 80A
QS2	Load-break 80A (customer's equipment)
TK60-1	Self-resetting thermal switch 60°C.
TK90-1	Button-driven thermal switch 90°C
U1	Heating temperature control board 48 kW
Additional electric heating section 48 kW (HE2)	
POWER 3	Power supply from the customer's feeder 80A
QS3	Load-break 80A (customer's equipment)
TK60-2	Self-resetting thermal switch 60°C.
TK90-2	Button-driven thermal switch 90°C
U2	DOL heater starting control board 48 kW

The basic layout of an AV06 UVU 6000-PRE-HE048 heating temperature control board 48 kW with the cover removed is shown below (ID for ordering 0688475613)

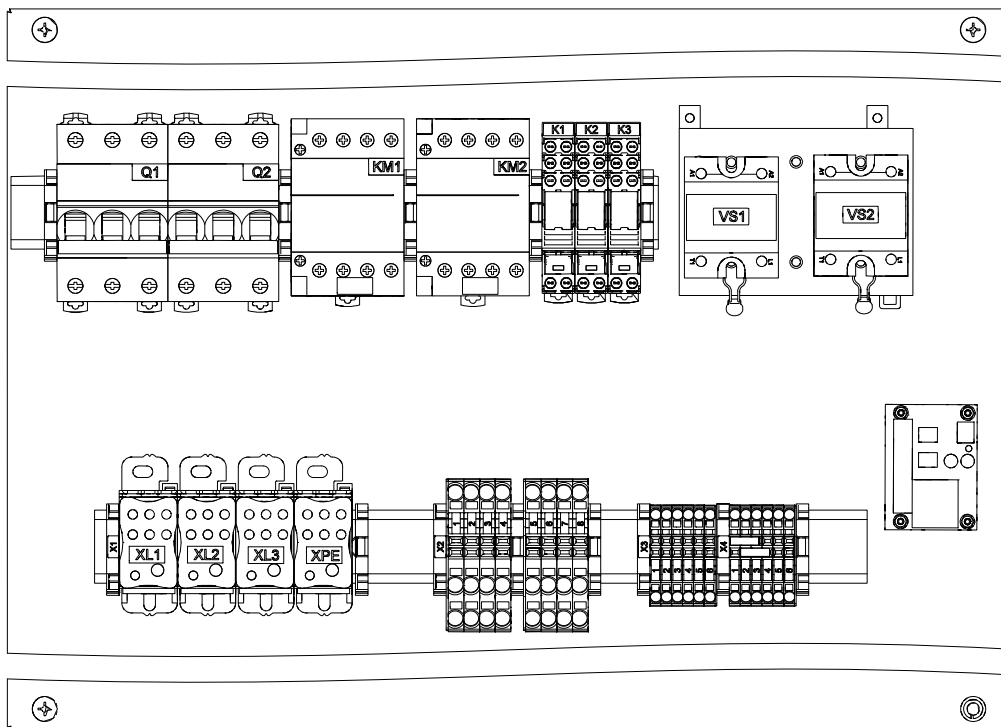

Designation of switches

Designation	Function	Value
Q1	Power supply protection of group of electric heating elements 24 kW	40A
Q2	Power supply protection of group of electric heating elements 24 kW	40A

External wiring diagram

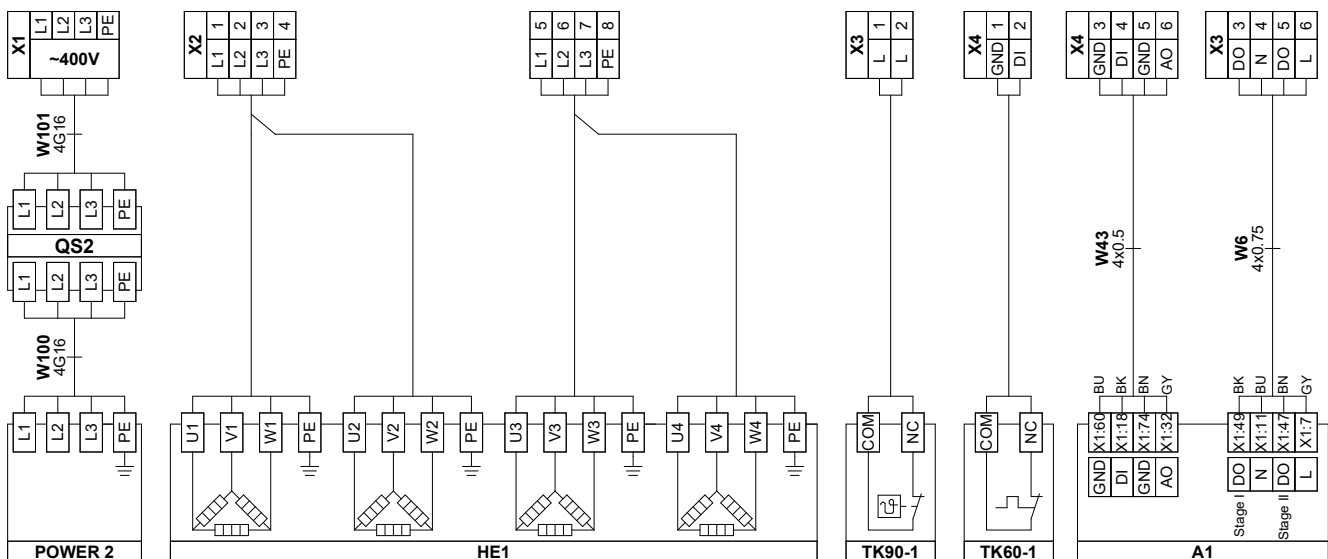

Designation	Name
A1	Controller board
HE1	48 kW electric heating section
POWER 2	Power supply from the customer's feeder 80A
QS2	Load-break 80A (customer's equipment)
TK60-1	Self-resetting thermal switch 60°C.
TK90-1	Button-driven thermal switch 90°C

The basic layout of an AV06 UVU 6000-RE-HE048 DOL starting controller board 48 kW with the cover removed is shown below (ID for ordering 0688477274)

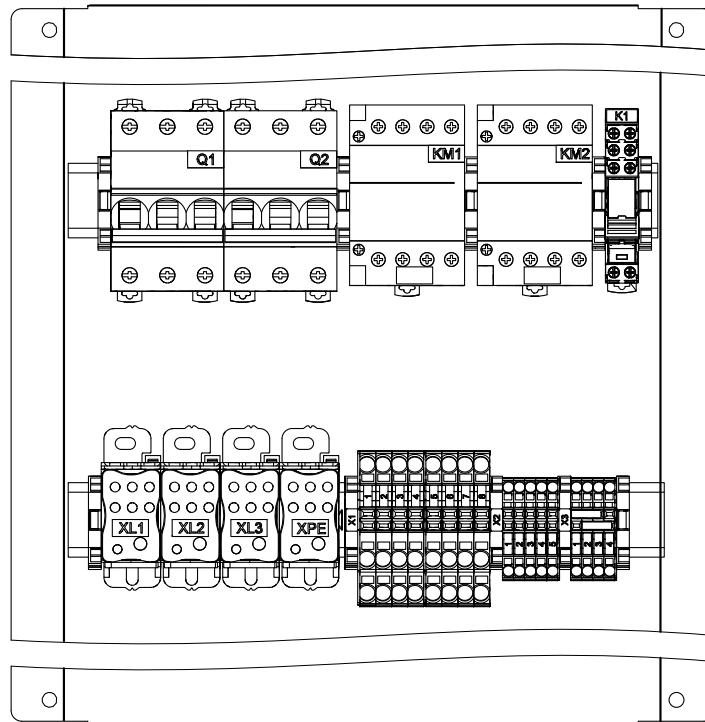

Designation of switches

Designation	Function	Value
Q1	Power supply protection of group of electric heating elements 24 kW	40A
Q2	Power supply protection of group of electric heating elements 24 kW	40A

External wiring diagram

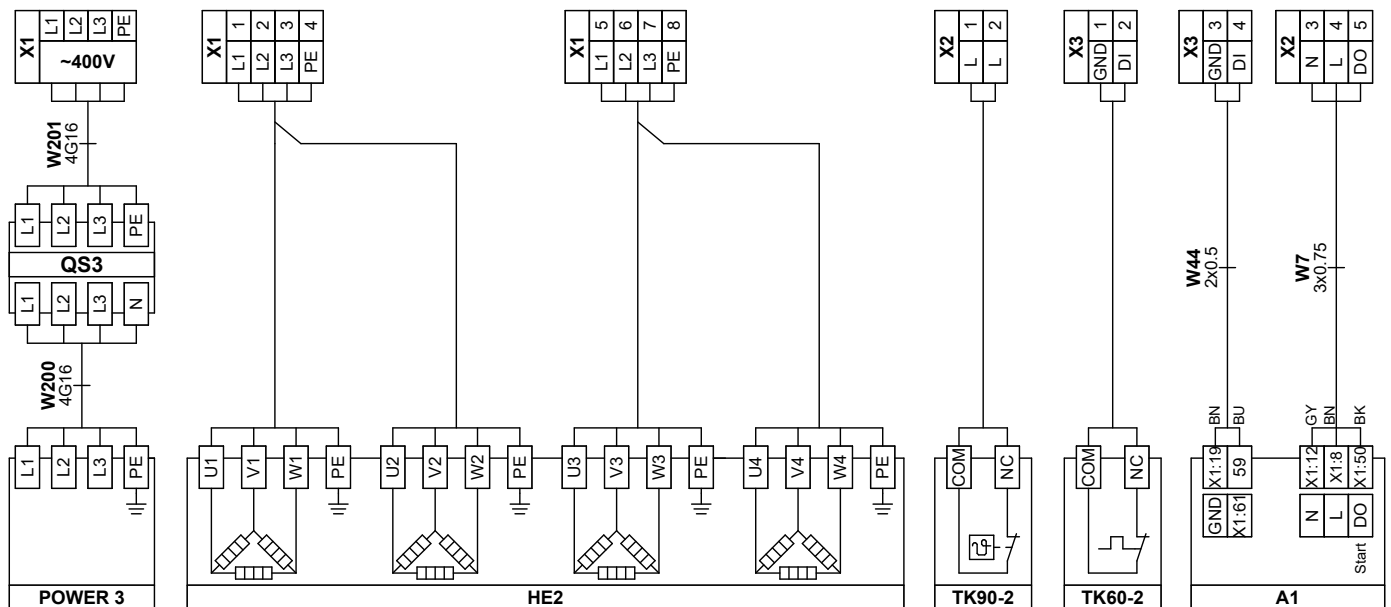

Designation	Name
A1	Controller board
HE2	Additional electric heating section 48 kW
POWER 3	Power supply from the customer's feeder 80A
QS3	Load-break 80A (customer's equipment)
TK60-2	Self-resetting thermal switch 60°C.
TK90-2	Button-driven thermal switch 90°C

AV06 UVU 8000 ... A30/31/32

The basic layout of an AV06 UVU 8000 2x (3PEC) controller board with the cover removed is shown below (ID for ordering 0688477533)

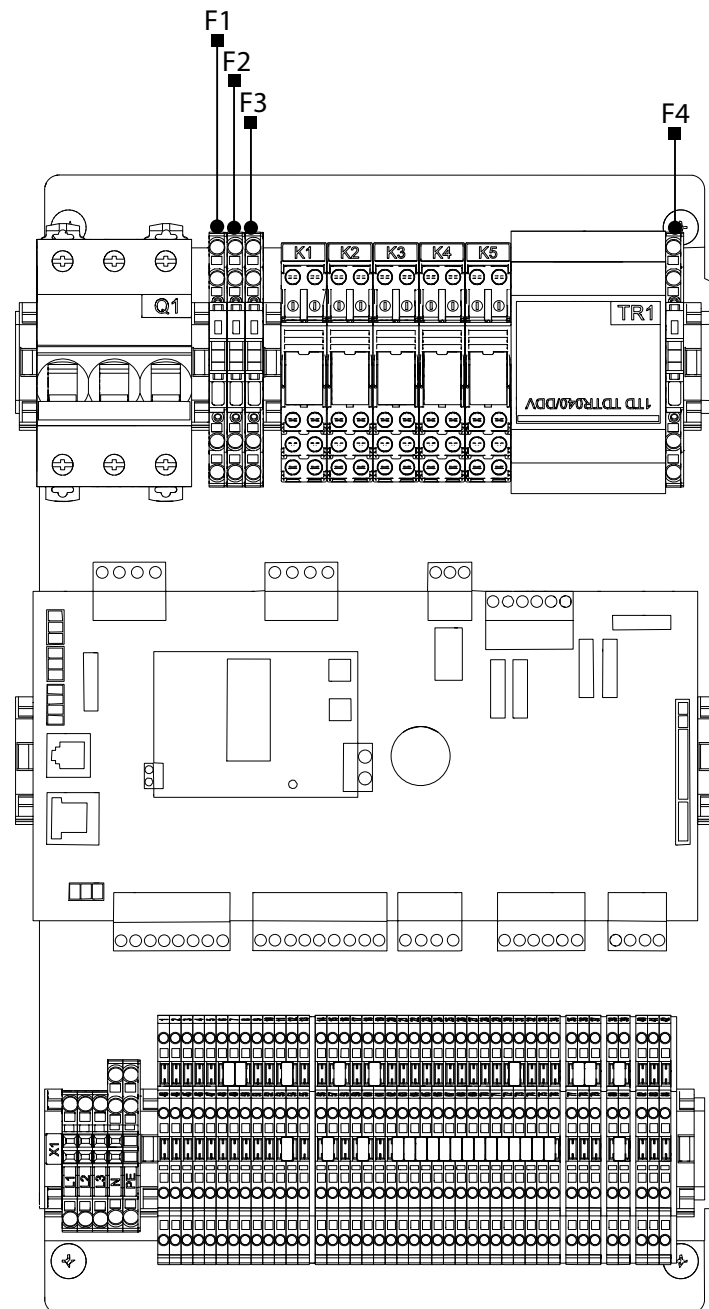

Designation of switches

Designation	Function	Value
F1	Power supply protection of the heating circulation pump	5A
F2	Power supply protection of the cooling circulation pump and the control board of the CCU	5A
F3	Power supply protection of the 230 VAC digital outputs and actuators	5A
F4	Power supply protection of the 24 VAC controller, sensors and actuators	3.15A
Q1	Power supply protection of the supply fans	6A

Replacement table of circuit breakers for their analogs for heating circulation pump power supply protection

Rated current [A]	5		
Manufacturing factory	LITTELFUSE	EATON/BUSSMANN	ESKA
Equipment code	0218005.MXP	BK1-S506-5-R	522.524
Breaking current	35A		
Circuit breaker size	5x20mm		
Circ. breaker characteristic	Slow		

Replacement table of circuit breakers and their analogs for 24 VAC controller, sensors and actuators power supply

Rated current [A]	3.15		
Manufacturing factory	LITTELFUSE	EATON/BUSSMANN	ESKA
Equipment code	02183.15MXP	BK1-S506-3-15-R	522.522
Breaking current	35A		
Circuit breaker size	5x20mm		
Circ. breaker characteristic	Slow		

Replacement table of circuit breakers and their analogs for power supply protection of cooling circulation pump and the control board of the CCU

Rated current [A]	5		
Manufacturing factory	LITTELFUSE	EATON/BUSSMANN	ESKA
Equipment code	0218005.MXP	BK1-S506-5-R	522.524
Breaking current	35A		
Circuit breaker size	5x20mm		
Circ. breaker characteristic	Slow		

Replacement table of circuit breakers for their analogs for protecting digital outputs' and 230 VAC actuators' power supply

Rated current [A]	5		
Manufacturing factory	LITTELFUSE	EATON/BUSSMANN	ESKA
Equipment code	0218005.MXP	BK1-S506-5-R	522.524
Breaking current	35A		
Circuit breaker size	5x20mm		
Circ. breaker characteristic	Slow		

External wiring diagram

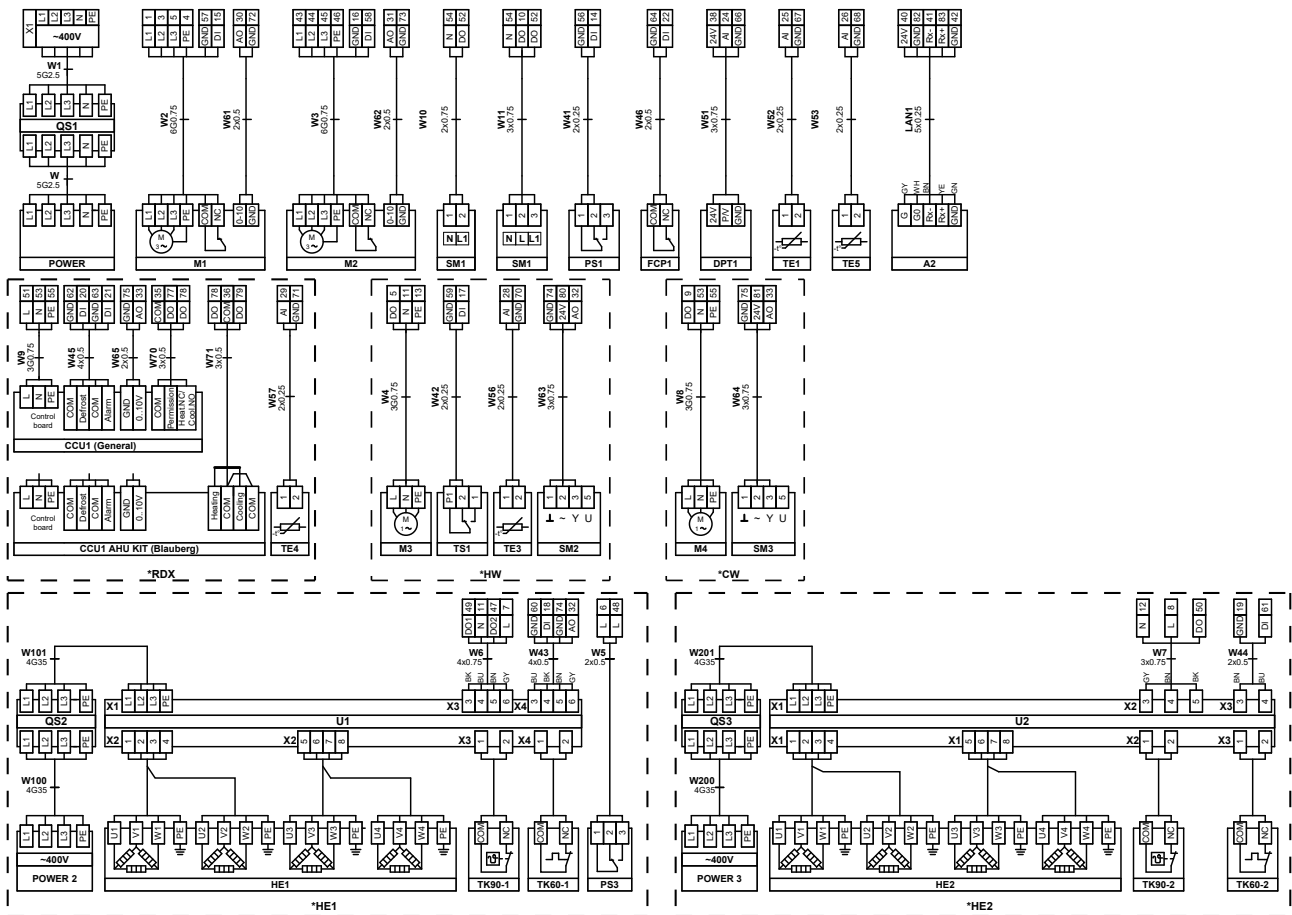

* Connect devices based on the order

** If the additional heating section HE2 is absent, install the jumper between the terminals 19 and 61

General equipment	
Designation	Name
A2	Control terminal
DPT1	Supply air pressure (VAV/CAV)
FCP1	Fire alarm (customer's equipment)
M1	Supply fan
POWER1	Power supply from the customer's feeder 25A
PS1	Fresh air filter differential pressure switch
SM1	Fresh air damper actuator
TE1	Intake air temperature
TE5	Temperature in the supply air duct
QS1	Load-break 25A (customer's equipment)

* Equipment is based on the order	
Designation	Name
Water heating (HW) section	
M2	Heating circulation pump
SM2	Three-way heating valve actuator
TE3	Heating temperature of the back water flow
TS1	Water heater frost protection
Water cooling (CW) section	
M3	Cooling circulation pump
SM3	Three-way cooling valve actuator
DX reverse heat exchanger (RDX) section	
CCU1	Compressor and condenser unit
TE4	Temperature upstream the compressor and condenser unit
72 kW electric heating (HE1) section	
PS3	Supply fan differential pressure switch (heating protection)
POWER 2	Power supply from the customer's feeder 125A
QS2	Load-break 125A (customer's equipment)
TK60-1	Self-resetting thermal switch 60°C.
TK90-1	Button-driven thermal switch 90°C
U1	Heating temperature control board 72 kW
Additional electric heating section 72 kW(HE2)	
POWER 3	Power supply from the customer's feeder 125A
QS3	Load-break 125A (customer's equipment)
TK60-2	Self-resetting thermal switch 60°C.
TK90-2	Button-driven thermal switch 90°C
U2	DOL heater starting control board 72 kW

The basic layout of an AV06 UVU 8000-PRE-HE072 heating temperature control board 48 kW with the cover removed is shown below (ID for ordering 0688477493)

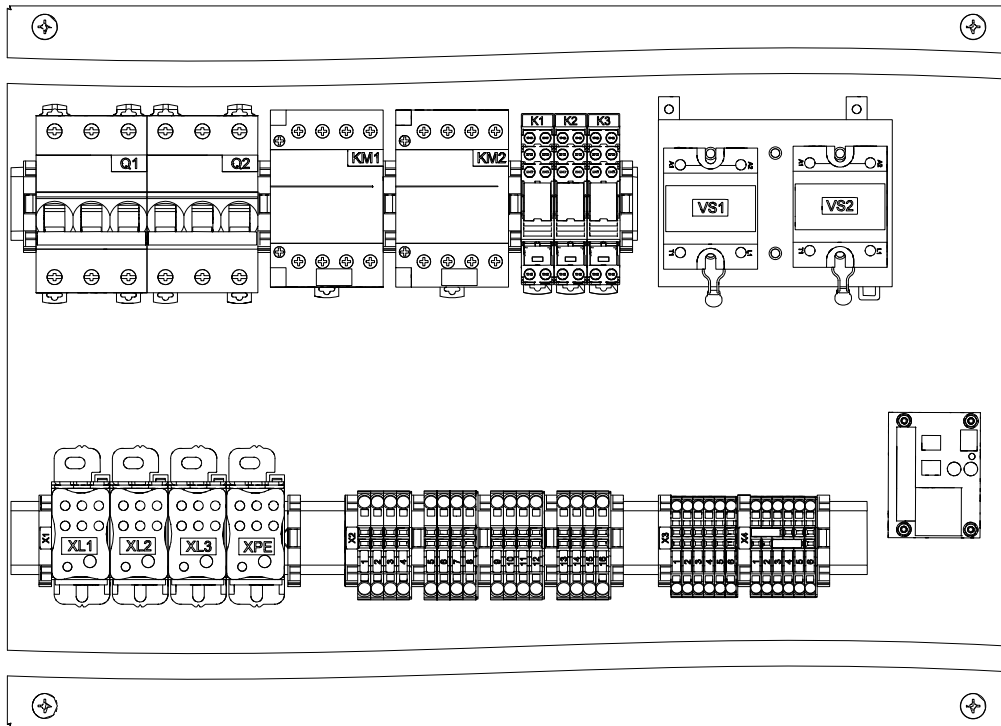

Designation of switches

Designation	Function	Value
Q1	Power supply protection of group of electric heating elements 36 kW	63A
Q2	Power supply protection of group of electric heating elements 36 kW	63A

External wiring diagram

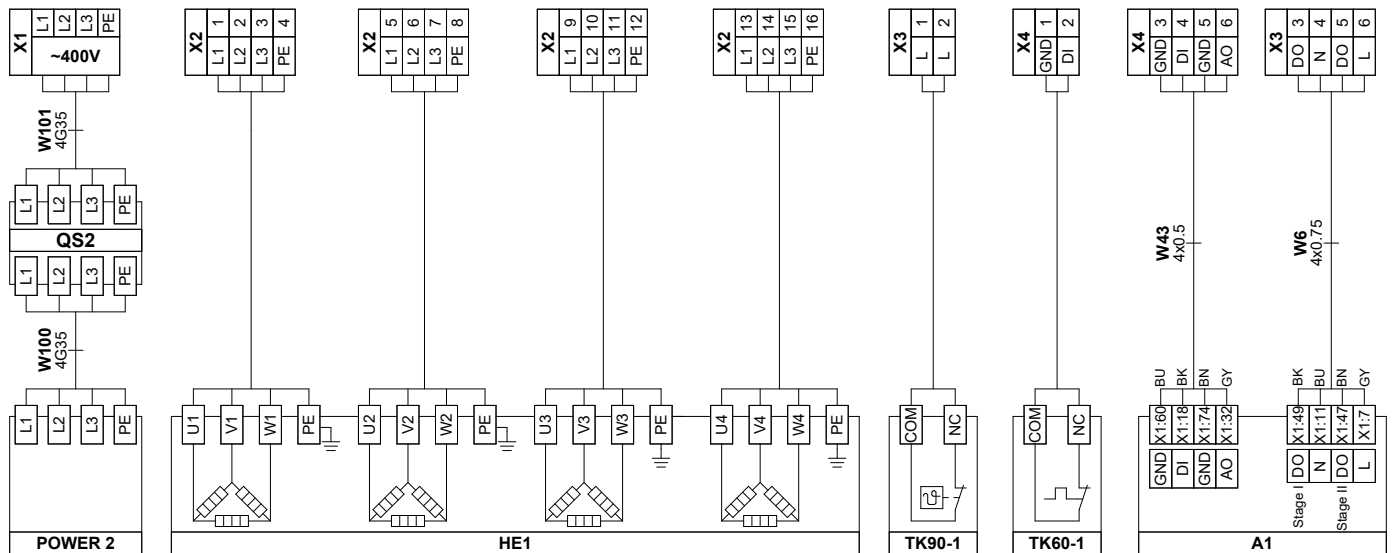

Designation	Name
A1	Controller board
HE1	72 kW electric heating section
POWER 2	Power supply from the customer's feeder 125A
QS2	Load-break 125A (customer's equipment)
TK60-1	Self-resetting thermal switch 60°C.
TK90-1	Button-driven thermal switch 90°C

The basic layout of an AV06 UVU 8000-PRE-HE072 DOL starting controller board 72 kW with the cover removed is shown below (ID for ordering 0688477336)

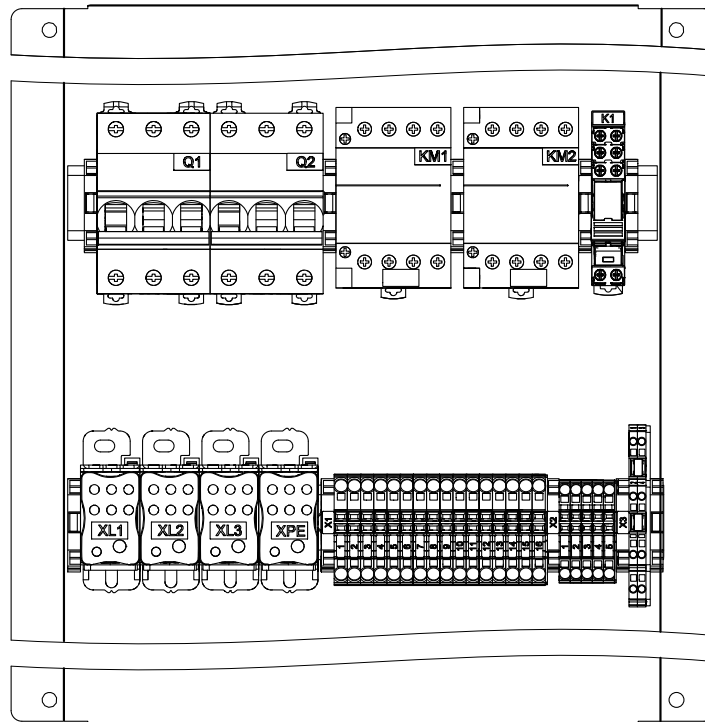

Designation of switches

Designation	Function	Value
Q1	Power supply protection of group of electric heating elements 36 kW	63A
Q2	Power supply protection of group of electric heating elements 36 kW	63A

External wiring diagram

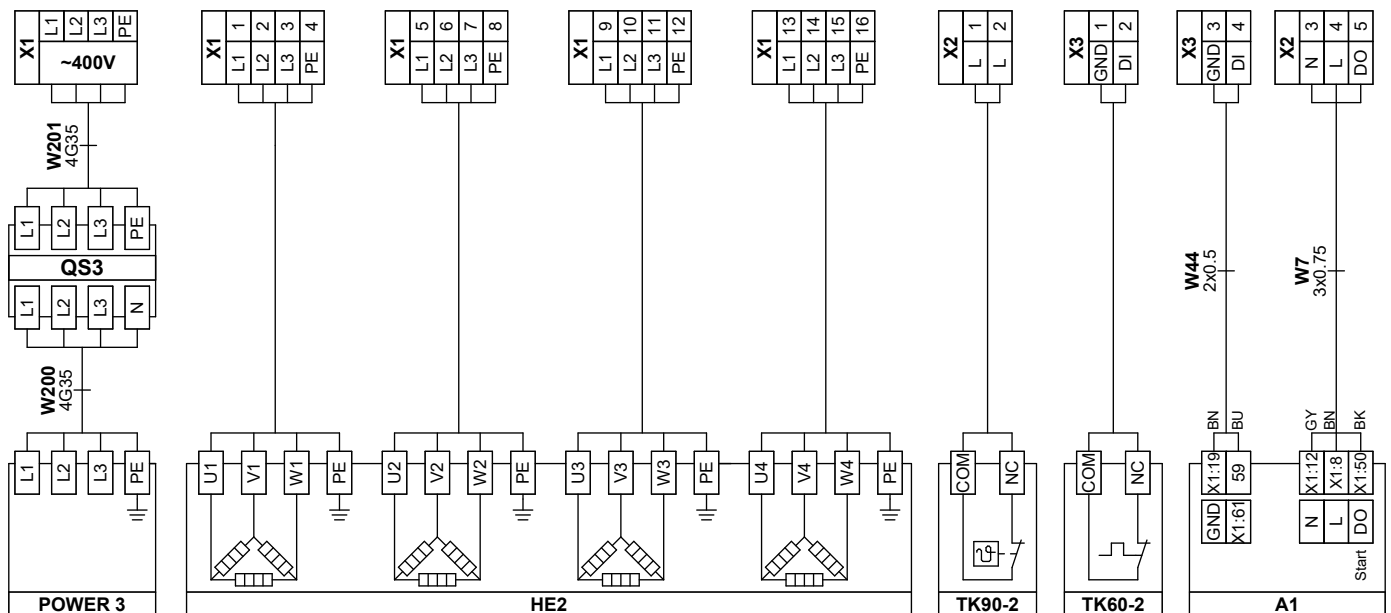

Designation	Name
A1	Controller board
HE2	Additional electric heating section 72 kW
POWER 3	Power supply from the customer's feeder 125A
QS3	Load-break 125A (customer's equipment)
TK60-2	Self-resetting thermal switch 60°C.
TK90-2	Button-driven thermal switch 90°C

STARTING SETUP

A trial run must be performed before running and constant operation of the unit. Remember, that only qualified and trained personnel can run the unit. Read the instructions and diagrams provided in the unit-related documentation and do the following steps before the trial run:

- ensure proper installation of the unit;
- ensure proper connection of all ventilation devices to the power mains;
- ensure proper connection of all hydraulic and electric equipment to the corresponding unit sections.

Electric equipment

Ensure proper connection, insulation and grounding of electric equipment according to the wiring diagrams and technical specifications of the delivered units. Check if insulation is intact on the wiring and the units. Installation works must comply with the conditions specified in the unit's technical documents.

Failure to comply voids the manufacturer's warranty. If installation works were performed by the manufacturer's personnel, then the warranty for electric equipment corresponds to the unit's warranty.

Electric heaters

Ensure that the heater is not clogged or damaged. Connect it in accordance with the wiring diagram. The connected heater should not touch any other elements of the unit.

Water heaters

Ensure that the pipelines (supply / back flow) are connected correctly; then check the heater plates. Adjust the frost protection thermostat's parameters one by one (factory settings: +5° C), as well as tight connection of the capillary tube to the heater's surface. The valve controlling the heater's operation must be installed in accordance with the marks on the casing.

Freon (DX), water and glycol coolers.

Check the plates of the cooler, ensure correct connection of the supply and back flow pipelines. Ensure correct installation of the U-trap and droplet separator relative to the air flow direction.

Filters

Ensure proper and tight fixation of filters and their general condition. Detailed filter data should be clarified in their corresponding documentation.

Fan section

The fan section's condition must be checked before running the unit. Ensure absence of any foreign objects in the section, e.g. transport fastening safety elements (yellow) and installation items, which may damage the unit. Unobstructed rotation of the impeller must be ensured.

Then, ensure that:

- the wiring complies with the wiring diagram;
- the fan's motor is connected correctly (the power mains voltage must be equal to the one specified on the motor);
- the grounding cable is correctly connected, if the fan is installed on rubber shock absorbers;
- all wires in the fan section are attached correctly.

If all the aforementioned procedures have been carried out, all panels of the unit may be closed.

TRIAL RUN

Only the accordingly trained and qualified personnel is authorized to carry out preparation, as well as the trial run of the unit. Proper functioning of the air dampers must be ensured before running the fans. Correct and safe operation of the unit can only be guaranteed when connected to the rated power mains.

The unit must operate for ca. 30 minutes after starting. Meanwhile, check the amperage of the electric equipment and the unit's air flow. Successful operation is characterized by absence of loud noise, foreign mechanical sounds, as well as vibrations in the unit while operating. Otherwise, troubleshooting must be carried out. If the aforementioned occurs, disconnect the unit from the power mains and check each of its sections again. After turning off the unit and before opening the panels, make sure that the impeller stopped. If it cannot be determined visually, panels should be opened no sooner than 3 minutes after disconnecting the unit from power mains. If no faults were noticed after 30 minutes of operation, the unit may be turned off and checked.

Check the following elements:

- filter fasteners;
- condensate drainage efficiency;
- the motor temperature and the fan group bearings.

After ensuring correct connections, correct operation of shock-vibration dampers must be ensured. Check the frost protection thermostat's operation if weather conditions allow it. It can be done if the supply air temperature remains below the value set on the thermostat. In this case, close the heat transfer medium supply to the heater temporarily at the supply air temperature of +1...2 °C. If the thermostat is turned on, it indicates correct operation.

If the trial run is carried out in the warm season, it should be checked the following cold season as soon as possible.

TECHNICAL MAINTENANCE



**DISCONNECT THE UNIT FROM POWER SUPPLY BEFORE ANY MAINTENANCE OPERATIONS!
MAKE SURE THE UNIT IS DISCONNECTED FROM POWER MAINS BEFORE REMOVING THE PROTECTION.**



**PRIOR TO COMMENCING ANY TECHNICAL MAINTENANCE PUT UP A PROHIBITORY SIGN ON THE FAN STARTING PANEL:
"DO NOT SWITCH ON! MEN AT WORK!"**



AVOID LIQUID SPILLS ON THE MOTOR! DO NOT USE AGGRESSIVE SOLVENTS AND SHARP OBJECTS FOR CLEANING!

Maintenance operations of the unit are required 3-4 times per year. They include general cleaning of the unit and the following operations:

1. Filter maintenance (3-4 times per year).

Dirty filters increase air flow resistance, which leads to a decrease in the supply of supply air to the room and creates preconditions for occurrence of faults. Filters should be replaced as they become dirty, but no less than 3-4 times a year.

To replace the filters, remove the cover of the unit casing (item 2 in the "Design and operating principle" section).

Rotate the locks that hold the filter. Carefully remove the dirty filter.

Install a new filter and cover in reverse order.

For new filters, contact the Seller.

2. Fan maintenance (once per year).

Even in case of regular maintenance of the filters, some dust may accumulate inside the fans and reduce the fan performance and supply air flow. Clean the fans with a soft brush or cloth. Do not use water, aggressive solvents, or sharp objects as they may damage the impeller.

3. Ductwork system maintenance (once in 5 years).

Even regular fulfilling of all the maintenance operations prescribed above may not completely prevent dirt accumulation in the air ducts, which reduces the system capacity. Duct maintenance means regular cleaning or replacement.

4. Control unit maintenance (as required).

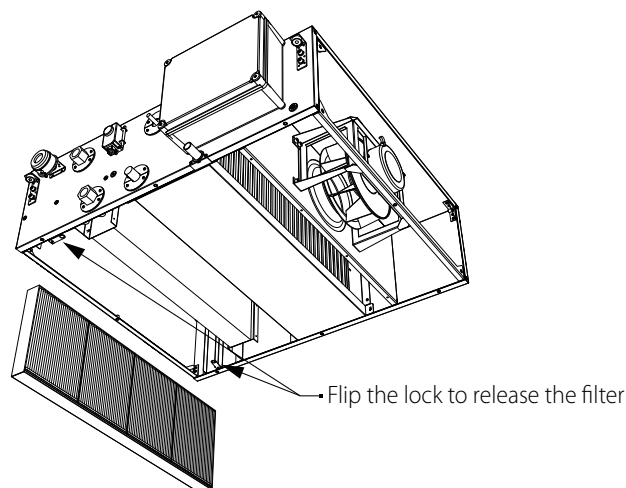

TROUBLESHOOTING

Trouble	Possible reasons	Troubleshooting
The unit does not start.	No power supply.	Make sure the power supply line is connected correctly, otherwise troubleshoot a connection error.
	Jammed motor.	Disconnect the fan from power supply. Troubleshoot the motor jamming. Restart the unit.
	The fan has overheated.	Disconnect the fan from power supply. Eliminate the cause of overheating. Restart the unit.
Automatic circuit breaker tripping after the unit start-up.	Overcurrent as a result of short circuit in the electric circuit.	Switch off the unit. Contact the Seller.
Noise, vibration or reduced air flow.	The fan impeller is soiled.	Clean the impellers.
	The fan or casing screw connection is loose.	Tighten the screw connection of the fan or the casing against stop.
	The ventilation system components (air ducts, diffusers, louvre shutters, grilles) are clogged or damaged.	Clean or replace the ventilation system components (air ducts, diffusers, louvre shutters, grilles).

If troubleshooting steps have failed, contact the Seller of the product.

In case of faults not described in the table, contact the Seller for further information.

FINAL MEASUREMENT OF OPERATING PARAMETERS

The technical maintenance of the unit includes routine measurements of the following parameters:

- Final measurements of air temperature and humidity in the outlet of the air handling unit.
- The operating parameters of the components in the connected heating and cooling equipment.
- Proper operation of the electrical equipment (power consumption measurements).
- Proper operation of the fan groups specific to maintaining the air flow and unit operation parameters.

All the work specific to the routine control measurements and technical maintenance operations must be confirmed with the appropriate documents.

STORAGE AND TRANSPORTATION REGULATIONS

- Store the unit in the manufacturer's original packaging box in a dry closed ventilated premise with temperature range from -20 °C to + 30 °C and relative humidity up to 70 %.
- Storage environment must not contain aggressive vapors and chemical mixtures provoking corrosion, insulation, and sealing deformation.
- Use suitable hoist machinery for handling and storage operations to prevent possible damage to the unit.
- Follow the handling requirements applicable for the particular type of cargo.
- The unit can be carried in the original packaging by any mode of transport provided proper protection against precipitation and mechanical damage. The unit must be transported only in the working position.
- Avoid sharp blows, scratches, or rough handling during loading and unloading.
- Prior to the initial power-up after transportation at low temperatures, allow the unit to warm up at operating temperature for at least 3-4 hours.

MANUFACTURER'S WARRANTY

The product is in compliance with EU norms and standards on low voltage guidelines and electromagnetic compatibility. We hereby declare that the product complies with the provisions of Electromagnetic Compatibility (EMC) Directive 2014/30/EU of the European Parliament and of the Council, Low Voltage Directive (LVD) 2014/35/EU of the European Parliament and of the Council and CE-marking Council Directive 93/68/EEC. This certificate is issued following test carried out on samples of the product referred to above.

The manufacturer hereby warrants normal operation of the unit for 24 months after the retail sale date provided the user's observance of the transportation, storage, installation, and operation regulations. Should any malfunctions occur in the course of the unit operation through the Manufacturer's fault during the guaranteed period of operation, the user is entitled to get all the faults eliminated by the manufacturer by means of warranty repair at the factory free of charge. The warranty repair includes work specific to elimination of faults in the unit operation to ensure its intended use by the user within the guaranteed period of operation. The faults are eliminated by means of replacement or repair of the unit components or a specific part of such unit component.

The warranty repair does not include:

- routine technical maintenance
- unit installation/dismantling
- unit setup

To benefit from warranty repair, the user must provide the unit, the user's manual with the purchase date stamp, and the payment paperwork certifying the purchase. The unit model must comply with the one stated in the user's manual. Contact the Seller for warranty service.

The manufacturer's warranty does not apply to the following cases:

- User's failure to submit the unit with the entire delivery package as stated in the user's manual including submission with missing component parts previously dismantled by the user.
- Mismatch of the unit model and the brand name with the information stated on the unit packaging and in the user's manual.
- User's failure to ensure timely technical maintenance of the unit.
- External damage to the unit casing (excluding external modifications as required for installation) and internal components caused by the user.
- Redesign or engineering changes to the unit.
- Replacement and use of any assemblies, parts and components not approved by the manufacturer.
- Unit misuse.
- Violation of the unit installation regulations by the user.
- Violation of the unit control regulations by the user.
- Unit connection to power mains with a voltage different from the one stated in the user's manual.
- Unit breakdown due to voltage surges in power mains.
- Discretionary repair of the unit by the user.
- Unit repair by any persons without the manufacturer's authorization.
- Expiration of the unit warranty period.
- Violation of the unit transportation regulations by the user.
- Violation of the unit storage regulations by the user.
- Wrongful actions against the unit committed by third parties.
- Unit breakdown due to circumstances of insuperable force (fire, flood, earthquake, war, hostilities of any kind, blockades).
- Missing seals if provided by the user's manual.
- Failure to submit the user's manual with the unit purchase date stamp.
- Missing payment paperwork certifying the unit purchase.



FOLLOWING THE REGULATIONS STIPULATED HEREIN WILL ENSURE A LONG AND TROUBLE-FREE OPERATION OF THE UNIT



USER'S WARRANTY CLAIMS SHALL BE SUBJECT TO REVIEW ONLY UPON PRESENTATION OF THE UNIT, THE PAYMENT DOCUMENT AND THE USER'S MANUAL WITH THE PURCHASE DATE STAMP

CERTIFICATE OF ACCEPTANCE

Unit Type	Unidirectional ventilation units
Model	
Serial Number	
Manufacture Date	
Quality Inspector's Stamp	

SELLER INFORMATION

Seller	
Address	
Phone Number	
E-mail	
Purchase Date	
This is to certify acceptance of the complete unit delivery with the user's manual. The warranty terms are acknowledged and accepted.	
Customer's Signature	

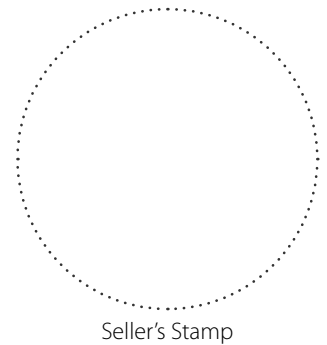

INSTALLATION CERTIFICATE

The _____ unit is installed pursuant to the requirements stated in the present user's manual.	
Company name	
Address	
Phone Number	
Installation Technician's Full Name	
Installation Date:	Signature:
The unit has been installed in accordance with the provisions of all the applicable local and national construction, electrical and technical codes and standards. The unit operates normally as intended by the manufacturer.	
Signature:	

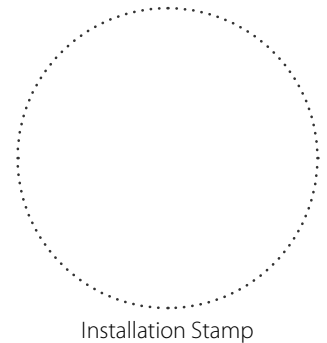

WARRANTY CARD

Unit Type	Unidirectional ventilation units
Model	
Serial Number	
Manufacture Date	
Purchase Date	
Warranty Period	
Seller	

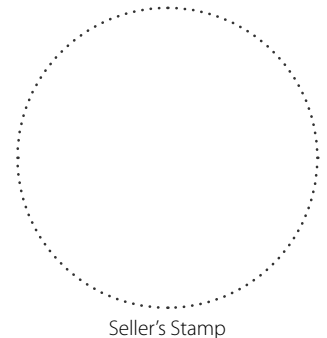



VENTS

