



VNV-1A(E) 80 KV2

Centrifugal fan
in plastic casing with
backward air discharge



Air capacity:
up to 100 m³/h

APPLICATION

- Exhaust ventilation of high-rise residential and non-residential premises with increased fire prevention requirements.
- Suitable for premises with mono-pipe ventilation system.
- Mounting in kitchens, bathrooms, toilets, storerooms and other household areas.

DESIGN

- Supplied in a KV2 80 plastic casing for flush-mounting into a wall with backward air discharge.
- The front panel is made of high-quality durable ABS plastic.
- Equipped with a plastic gravitational back-draft damper.
- The turnable front panel conceals possible inaccuracies of the fan casing installation.
- Rotating front cover allows eliminating inaccuracies during mounting of the fan casing.
- Connected with the main ventilation shaft with a flexible air duct.
- Connecting branch pipe diameter – 80 mm.

MOTOR

- Energy-efficient 2-speed motor on ball bearings with minimum energy demand.
- Independent maintenance of pressure and air flow rate in the duct.
- Fastened to the casing by means of latches with no tools.
- For precise characteristics, low noise level and safe operation each turbine is dynamically balanced while assembly.

CONTROL

- Speed switch is performed with the external manual switch. For example, P2-1-300 (switches are supplied separately).

MODIFICATIONS AND OPTIONS

- **VNV-1A(E) 80 KV2 T** – the fan is equipped with a timer.
- **VNV-1A(E) 80 KV2 TR** – the fan is equipped with an adjustable timer.
- **VNV-1A(E) 80 KV2 I** – the fan is equipped with an interval switch.
- **VNV-1A(E) 80 KV2 H** – the fan is equipped with a humidity sensor. In case of second room ventilation system the casing is equipped with extra branch pipes with three air duct layout modifications for adjacent room ventilation. In such a case the kit for exhaust ventilation of the adjacent room is used.

ORDER REF.NO.

VNV-	Front panel	Air flow [m ³ /h]	80 KV2	Additional options	Front panel colour
	1 – plastic	A – 35/60 E – 75/100		T TR I H	_ – white

OPTIONS DESCRIPTION

Name	Description
T timer modification	The fan is switched on to the maximum speed manually with the external switch, turn-on delay time is 50 seconds. The return to default position is performed with the timer, run-out time is 6 minutes. Continuous low speed operation is possible.
TR adjustable timer modification	The fan can be switched to the maximum speed manually with the external switch. Turn-on delay time is set with the internal regulator ranging from 0 to 150 seconds. Run-out time is set with the internal regulator from 2 to 30 minutes. Continuous low speed operation is possible.
I interval switch modification	The fan switches periodically to the maximum speed while operation. The switching interval is set by means of the internal regulator ranging between 0.5 and 15 hours. Run-out time is 10 minutes. The fan can be switched manually with the external switch, turn-on delay time is 50 seconds. Continuous low speed operation is possible.
H humidity sensor modification	The fan switches to the maximum speed as relative humidity level in the room increases. It switches off as relative humidity level drops by 10 % below the set level. The humidity threshold is adjusted in the range between 60 % and 90 %. Force switching to the maximum speed is provided, in this case the turn-on delay time is 50 seconds, and the run-out time is set by the internal regulator between 2 and 30 minutes. Continuous low speed operation is possible.

MOUNTING EXAMPLE

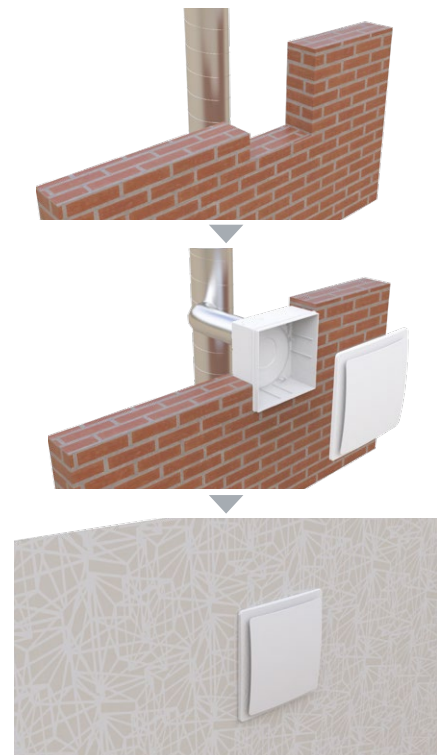

The fan casing is mounted during construction works. Electric wiring for connection of the VNV-1A(E) 80 ventilation unit is led out through a special hole in the casing. The front panel is covered with the protective cardboard plate supplied with the unit to avoid damages or contamination during finishing works in the room. After finishing the works the protective cardboard plate is removed and the VNV-1A(E) 80 ventilation unit is installed into the casing that is connected to the wiring.

AERODYNAMIC CHARACTERISTICS

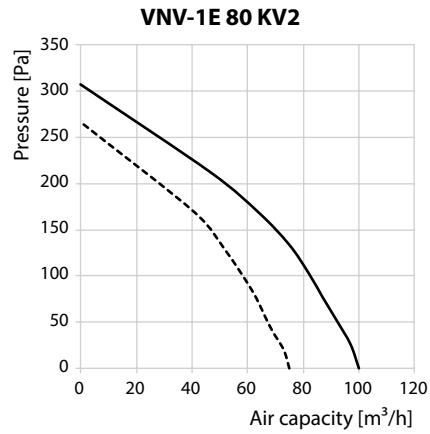
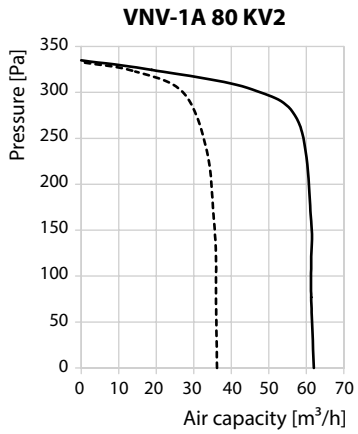



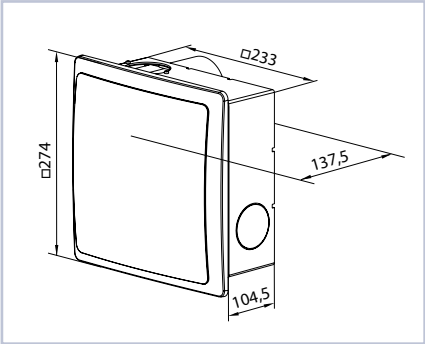

TECHNICAL DATA

	VNV-1A 80 KV2		VNV-1E 80 KV2	
	1	2	1	2
Number of speeds	1	2	1	2
Frequency [Hz]	50		50	
Voltage [V]	220-240		220-240	
Power consumption [W]	15	25	24	29
Current [A]	0.12	0.14	0.11	0.13
Maximum air flow [m³/h]	35	63	75	100
SFP [W/l/s]	1.54	1.43	1.15	1.04
Sound pressure level at 3 m distance [dBA]	27	36	29	38
Weight [kg]	2.7		2.7	
IP	IP55		IP55	

OVERALL DIMENSIONS



ACCESSORIES

Filter	Speed switch	Bracket	Thermovent	Clamps
				

CERTIFICATES



The fans meet safety norms and standards and electromagnetic compatibility directives.