

USER'S MANUAL

VUT 160 PB EC
VUT 250 PB EC
VUT 350 PB EC

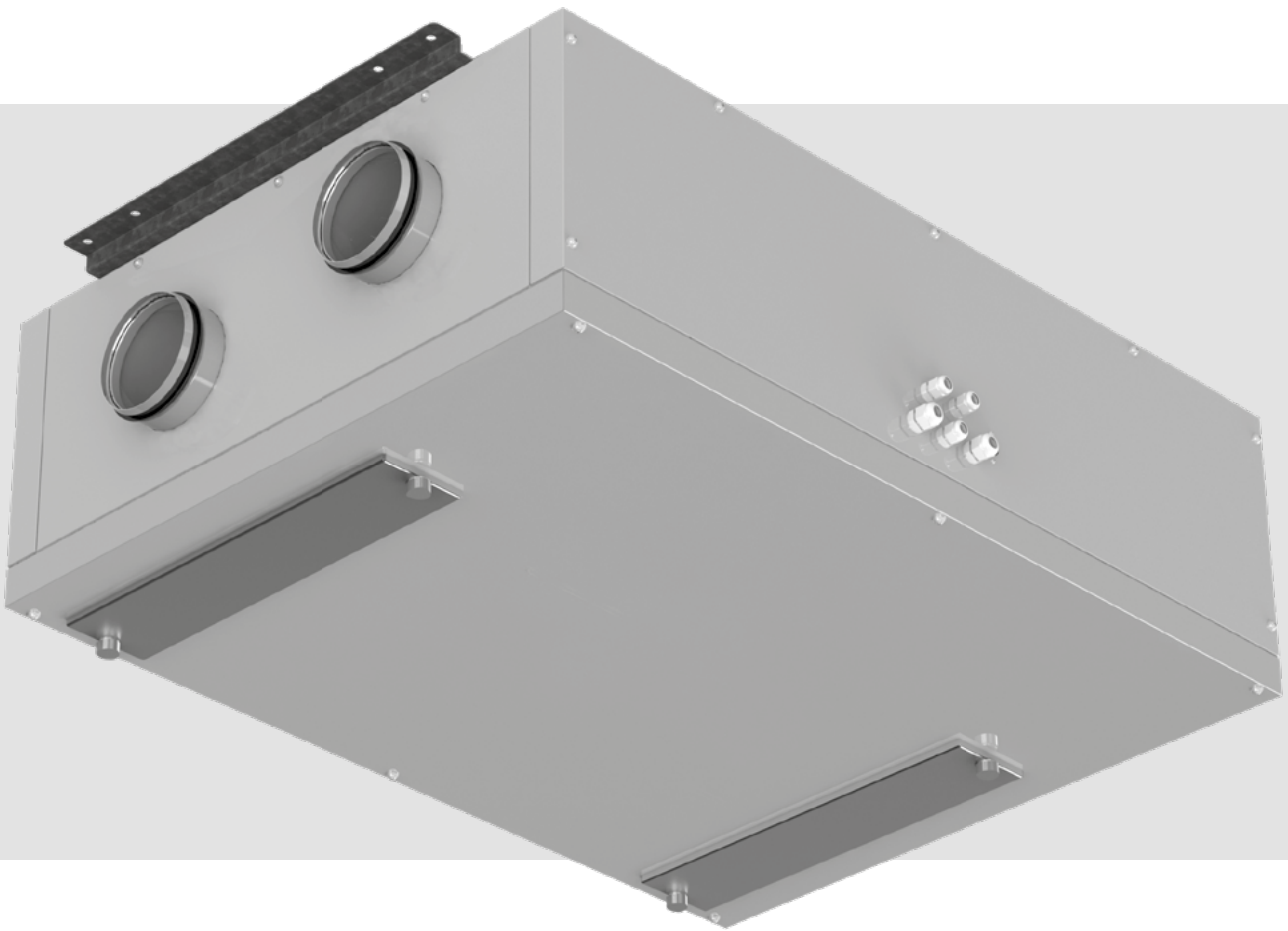

Heat recovery air handling unit

CONTENTS

Safety requirements.....	2
Purpose.....	5
Delivery set.....	5
Designation key.....	5
Technical data.....	6
Unit design and operating principle.....	8
Installation and set-up.....	11
Connection to power mains	15
Technical maintenance.....	17
Storage and transportation regulations.....	18
Manufacturer's warranty	19
Certificate of acceptance.....	20
Seller information.....	20
Installation certificate.....	20
Warranty card.....	20

This user's manual is a main operating document intended for technical, maintenance, and operating staff.

The manual contains information about purpose, technical details, operating principle, design, and installation of the VUT 160/250/350 PB EC unit and all its modifications.

Technical and maintenance staff must have theoretical and practical training in the field of ventilation systems and should be able to work in accordance with workplace safety rules as well as construction norms and standards applicable in the territory of the country.

SAFETY REQUIREMENTS

This unit is not intended for use by persons (including children) with reduced physical, sensory or mental capabilities, or lack of experience and knowledge, unless they have been given supervision or instruction concerning use of the unit by a person responsible for their safety. Children should be supervised to ensure that they do not play with the unit.

This appliance can be used by children aged from 8 years and above and persons with reduced physical, sensory or mental capabilities or lack of experience and knowledge if they have been given supervision or instruction concerning use of the appliance in a safe way and understand the hazards involved.

Cleaning and user maintenance shall not be done by children without supervision.

Children shall not play with the appliance.

Connection to the mains must be made through a disconnecting device, which is integrated into the fixed wiring system in accordance with the wiring rules for design of electrical units, and has a contact separation in all poles that allows for full disconnection under overvoltage category III conditions.

If the supply cord is damaged, it must be replaced by the manufacturer, its service agent, or similarly qualified persons in order to avoid a safety hazard.

CAUTION: In order to avoid a safety hazard due to inadvertent resetting of the thermal cut-out, this unit must not be supplied through an external switching device, such as a timer, or connected to a circuit that is regularly switched on and off by the utility.

Ensure that the unit is switched off from the supply mains before removing the guard.

WARNING: If there are any unusual oscillating movements, immediately stop using the unit and contact the manufacturer, its service agent or suitably qualified persons.

The replacement of parts of the safety suspension system device shall be performed by the manufacturer, its service agent or suitably qualified persons.

Precautions must be taken to avoid the back-flow of gases into the room from the open flue of gas or other fuel-burning appliances.

The appliance may adversely affect the safe operation of appliances burning gas or other fuels (including those in other rooms) due to back flow of combustion gases. These gases can potentially result in carbon monoxide poisoning. After installation of the unit the operation of flued gas appliances should be tested by a competent person to ensure that back flow of combustion gases does not occur.

Fixing means for attachment to the ceiling such as hooks or other devices shall be fixed with a sufficient strength to withstand 4 times the weight of the appliance.

The mounting of the suspension system shall be performed by the manufacturer, its service agent or suitably qualified persons.

The appliance is to be installed so that the blades are more than 2.3m (2,1 m AU) above the floor.

All operations described in this manual must be performed by qualified personnel only, properly trained and qualified to install, make electrical connections and maintain ventilation units.

Do not attempt to install the product, connect it to the mains, or perform maintenance yourself. This is unsafe and impossible without special knowledge.

Disconnect the power supply prior to any operations with the unit.

All user's manual requirements as well as the provisions of all the applicable local and national construction, electrical, and technical norms and standards must be observed when installing and operating the unit.

Disconnect the unit from the power supply prior to any connection, servicing, maintenance, and repair operations.

Connection of the unit to power mains is allowed by a qualified electrician with a work permit for the electric units up to 1000 V after careful reading of the present user's manual.

Check the unit for any visible damage of the impeller, the casing, and the grille before starting installation. The casing internals must be free of any foreign objects that can damage the impeller blades.

While mounting the unit, avoid compression of the casing! Deformation of the casing may result in motor jam and excessive noise.

Misuse of the unit and any unauthorised modifications are not allowed.

Do not expose the unit to adverse atmospheric agents (rain, sun, etc.).

Transported air must not contain any dust or other solid impurities, sticky substances, or fibrous

materials.

Do not use the unit in a hazardous or explosive environment containing spirits, gasoline, insecticides, etc.

Do not close or block the intake or extract vents in order to ensure the efficient air flow.

Do not sit on the unit and do not put objects on it.

The information in this user's manual was correct at the time of the document's preparation.

The Company reserves the right to modify the technical characteristics, design, or configuration of its products at any time in order to incorporate the latest technological developments.

Never touch the unit with wet or damp hands.

Never touch the unit when barefoot.

BEFORE INSTALLING ADDITIONAL EXTERNAL DEVICES, READ THE RELEVANT USER MANUALS.



THE PRODUCT MUST BE DISPOSED SEPARATELY AT THE END OF ITS SERVICE LIFE.

DO NOT DISPOSE THE UNIT AS UNSORTED DOMESTIC WASTE.

PURPOSE

The unit is designed to ensure continuous mechanical air exchange in houses, offices, hotels, cafes, conference halls, and other utility and public spaces as well as to recover the heat energy contained in the air extracted from the premises to warm up the filtered stream of intake air.

The unit is not intended for organizing ventilation in swimming pools, saunas, greenhouses, summer gardens, and other spaces with high humidity.

Due to the ability to save heating energy by means of energy recovery, the unit is an important element of energy-efficient premises.

The unit is a component part and is not designed for stand-alone operation. It is rated for continuous operation.

Transported air must not contain any flammable or explosive mixtures, evaporation of chemicals, sticky substances, fibrous materials, coarse dust, soot and oil particles or environments favourable for the formation of hazardous substances (toxic substances, dust, pathogenic germs).

DELIVERY SET

Air handling unit	1 pc.
User's manual	1 pc.
Control panel (only for units with A11 and A14 automation)	1 pc.
Mounting box for wall flush mounting (only for units with A14 automation)	1 pc.
Mounting box for wall surface mounting (only for units with A14 automation)	1 pc.
Fastening kit	1 pc.
Packing box	1 pc.

DESIGNATION KEY

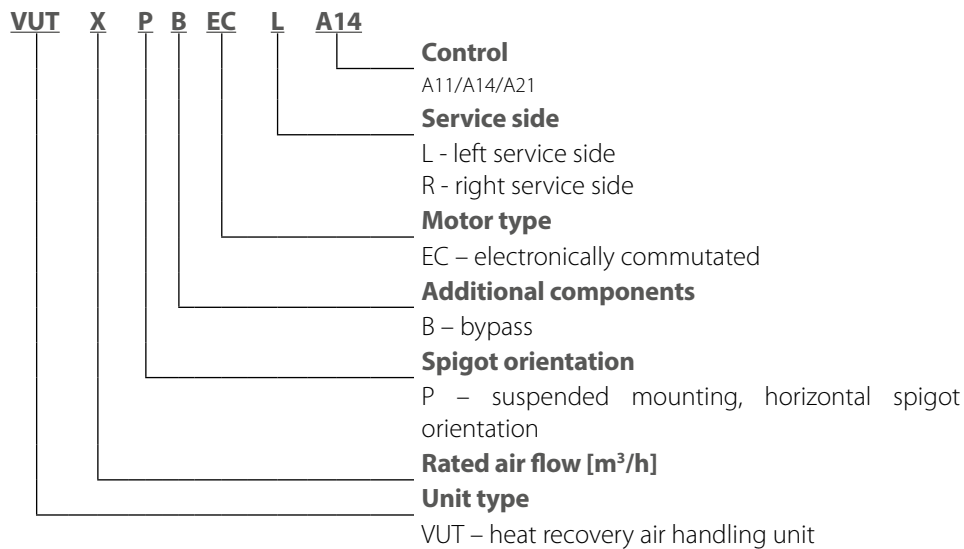

TECHNICAL DATA

The unit is designed for indoor application with the ambient temperature ranging from +1 °C up to +40 °C and relative humidity up to 60 % without condensation. In cold, damp rooms, there is a possibility of freezing or condensation inside and outside the casing. In order to prevent condensation on the internal walls of the unit, it is necessary that the surface temperature of the casing is 2-3 °C above the dew point temperature of the transported air.

The unit should be operated continuously, and in cases where ventilation is not necessary, reduce the air flow of the fans to a minimum (20%). This will ensure a favorable indoor climate and reduce the amount of condensation inside the unit, which can damage electronic components. Never use the unit for dehumidification, for example, of new buildings.

The unit is rated as a Class I electrical appliance.

Hazardous parts access and water ingress protection rating:

IP22 for the unit connected to the air ducts

IP44 for the unit motors

The unit design is constantly being improved, thus some models may be slightly different from those described in this manual.

MODEL	VUT 160 PB EC	VUT 250 PB EC	VUT 350 PB EC
Supply voltage, 50 (60) Hz [V]	1~ 220 – 240		
Nominal power consumption [W]	50	101	170
Current [A]	0.4	0.8	1.3
Maximum air flow [m ³ /h]	190	270	410
RPM, min ⁻¹	3770	4480	3200
Sound pressure level at 3 m distance [dBA]	26	28	34
Transported air temperature [°C]	from -25 up to +40		
Casing material	aluzinc steel		
Insulation (mineral wool) [mm]	40 mm	40 mm	40 mm
Extract filter	G4		
Supply filter	F7		
Connected air duct diameter [mm]	Ø 125	Ø 125	Ø 160
Weight [kg]	48	48	70
Heat recovery efficiency	from 82 up to 94 %	from 80 up to 98 %	from 80 up to 91 %
Heat exchanger type	counter-flow		
SEC class	A+	A	A+

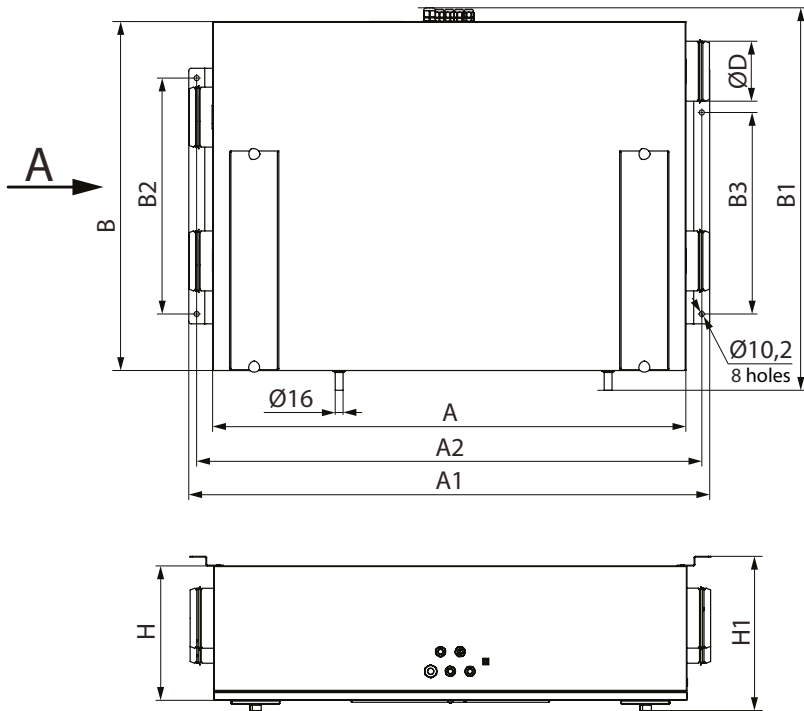

LEFT-HANDED MODIFICATION

A view (indoor connection)

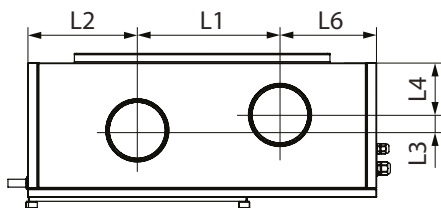

B view (outdoor connection)

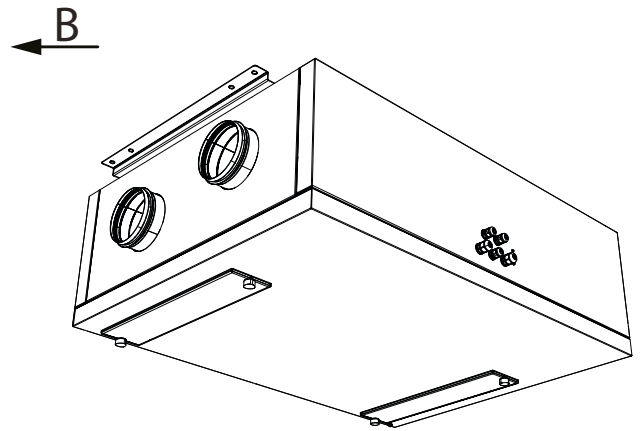
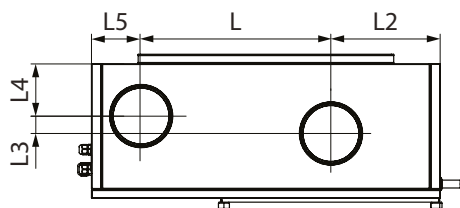

RIGHT-HANDED MODIFICATION

A view (outdoor connection)

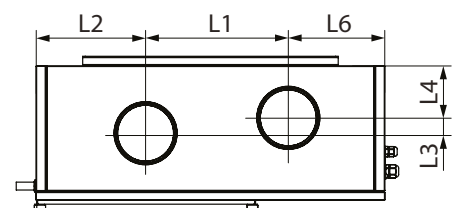

B view (indoor connection)

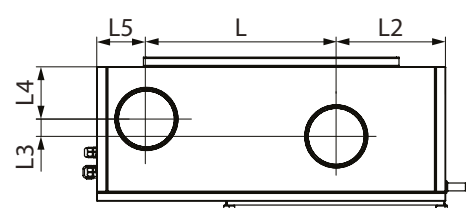

Model	Dimensions [mm]																
	ØD	A	A1	A2	B	B1	B2	B3	H	H1	L	L1	L2	L3	L4	L5	L6
VUT 160 PB EC	125	1008	1105	1073	754	822	480	410	320	361	386	293	245	31	128	123	216
VUT 250 PB EC	125	1008	1105	1073	754	822	480	410	320	361	386	293	245	31	128	123	216
VUT 350 PB EC	160	1138	1235	1203	1044	1112	680	610	320	361	555	417	345	40	119	144	282

UNIT DESIGN AND OPERATING PRINCIPLE

The unit has the following operating logic: warm stale extract air from the room flows into the unit, where it is filtered by the extract filter, then air flows through the heat exchanger and is exhausted outside by the extract fan. Cold fresh air from the outside flows into the unit, where it is cleaned by the supply filter.

Then the air flows through the heat exchanger and is directed to the room with the supply fan. Heat energy of warm extract air is transferred to clean intake fresh air from the outside and warms it up. The air flows are fully separated while flowing through the heat exchanger. Heat recovery minimizes heat losses, which reduces the cost of space heating in the cold season.

The difference between the supply and extract air flow temperature leads to condensate generation. Condensate is collected in the drain pan and is removed outside through the drain pipe.

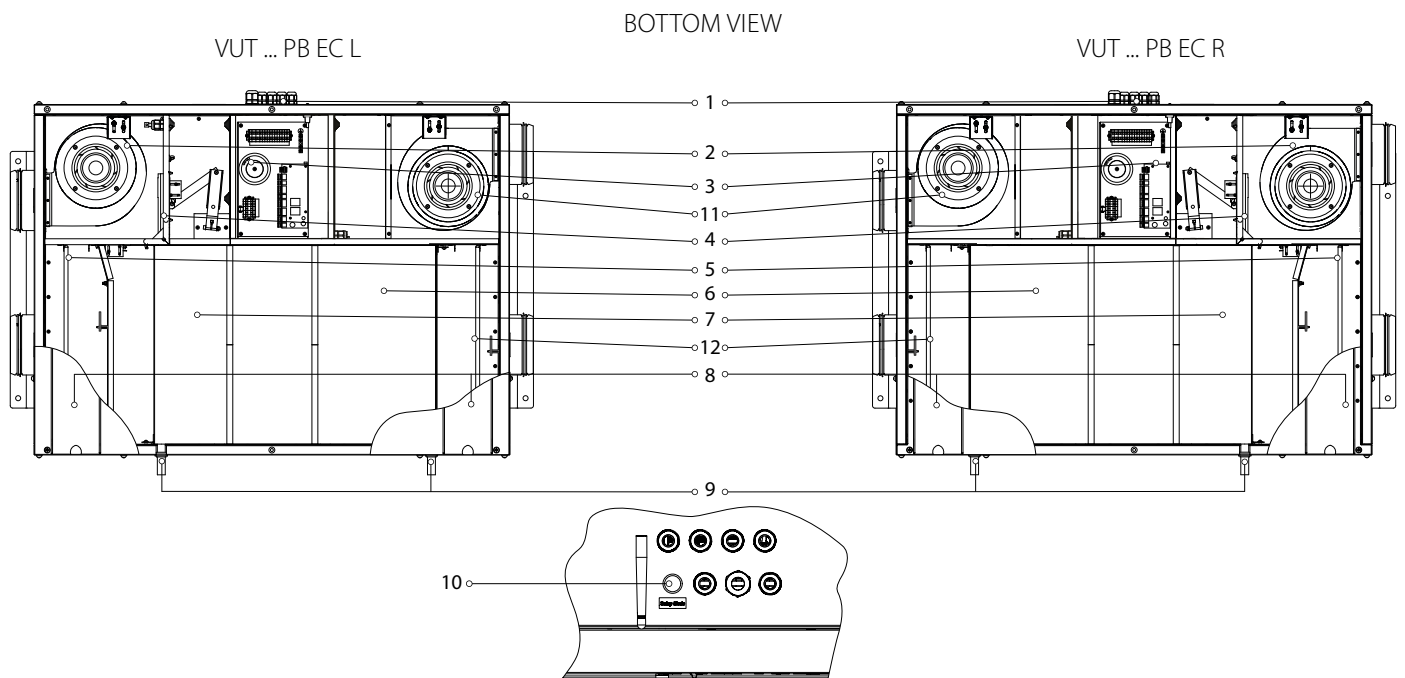

1 – cable glands; 2 – supply fan; 3 – control unit; 4 – bypass damper; 5 – extract filter; 6 – counter-flow heat exchanger; 7 – drain pan; 8 – detachable plates for technical maintenance of filters; 9 – drain pipe; 10 – SETUP MODE button (for VUT 160/250/350 PB EC A21 units); 11 – extract fan; 12 – supply filter.

Additional equipment (is not included in the delivery set, can be ordered separately)

Humidity sensor.

The HV2 humidity sensor is connected to the controller in VUT 160/250/350 PB EC A21 models, and to the terminal block in VUT 160/250/350 PB EC A14 models. The HR-S humidity sensor is connected to the controller. The unit with the installed humidity sensor maintains a set indoor humidity point. As the extract air humidity rises above the set point, the system automatically switches to the maximum speed. As the humidity drops down below the set point the unit returns to the previous mode.

CO₂ sensor (connected to the controller)

Measures the level of concentration of carbon dioxide in the room and generates a signal that controls the performance of the fan. Air capacity control based on CO₂ concentration is an efficient energy saving solution.

VOC sensor (connected to the controller)

Qualitative assessment of air saturation with contaminants (cigarette smoke, exhaled air, solvent and detergent vapours). The sensor sensitivity can be adjusted with regards to the expected maximum level of air pollution. Enables on-demand ventilation which results in considerable energy savings as air is exchanged only upon reaching the preset level of pollution.

Duct preheater.

The heater maintains the duct air temperature at a point that prevents the heat exchanger freezing. Heater installation and connection to the unit are described in the heater user's manual.

Duct reheater.

The heater maintains the room temperature set by the user. Heater installation and connection to the unit are described in the heater user's manual.

Compatibility table of optional equipment and unit models

	HV1 internal humidity sensor	HV2 internal humidity sensor	CO2-1 room sensor	CO2-2 room sensor	Room humidity sensor	VOC room sensor (0-10 V)	CO2 room sensor (0-10 V)	Room humidity sensor (0-10 V)	Preheater	Reheater
VUT 160/250/350 PB EC A11	+	—	—	—	—	—	—	—	+	—
VUT 160/250/350 PB EC A14	—	+	+	+	+	—	—	—	—	—
VUT 160/250/350 PB EC A21	—	+	+	+	+	+	+	+	+	+

UNIT OPERATION MODES

Heat recovery mode: warm stale extract air from the room flows into the unit, where it is filtered by the extract filter, then air flows through the heat exchanger and is exhausted outside by the extract fan.

Cold fresh air from the outside flows into the unit, where it is cleaned by the supply filter.

Then the air flows through the heat exchanger and is directed to the room with the supply fan.

Supply air is heated in the heat exchanger by transferring the heat energy of warm and humid extract air to the cold fresh air. The air flows are fully separated while flowing through the heat exchanger. Heat recovery minimizes heat losses, which reduces the cost of space heating in the cold season.

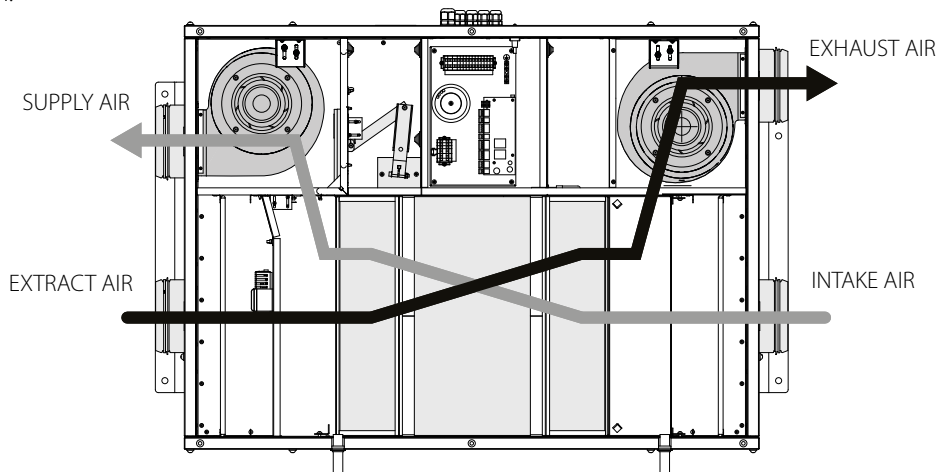

Freeze protection (danger of freezing appears when the exhaust air temperature downstream of the heat exchanger is lower than +5 °C and intake air temperature upstream of the heat exchanger is lower than -3 °C for the units with preheating, and when exhaust temperature downstream of the heat exchanger is lower than +3 °C for the units without preheating). To protect the heat exchanger from freezing in the cold season, the unit has a Frost Protection mode based on the temperature sensor readings.

The sensor is installed in the exhaust air duct downstream of the heat exchanger.

The Frost Protection mode is activated at an exhaust air temperature of +3 °C.

After temperature increase the unit returns to the previous operation mode.

In VUT 160/250/350 PB EC A11 units the frost protection mode must be activated, see the User's manual of the control panel. In case of freezing danger, the supply fan is turned off in VUT 160/250/350 PB EC A14 units. After temperature increase the unit returns to the previous operation mode. The VUT 160/250/350 PB EC A21 units have three frost protection modes: - gradual reduction of the supply fan speed - with the bypass - with the electric preheater (if the unit is equipped with a duct preheater). Mode selection and settings are described in the User's manual for the control system.

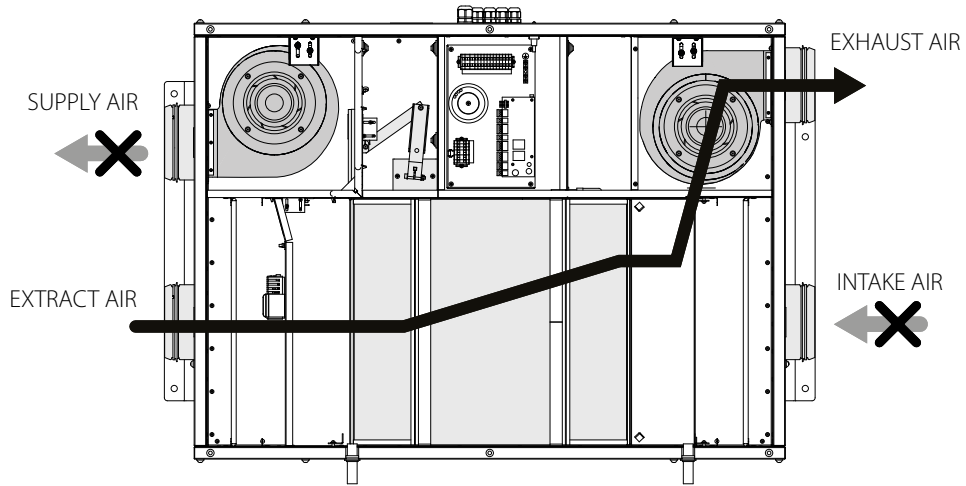

Summer Cooling mode: the bypass damper is opened, the intake air that is supplied to the premises bypasses the heat exchanger. The intake air temperature remains constant.

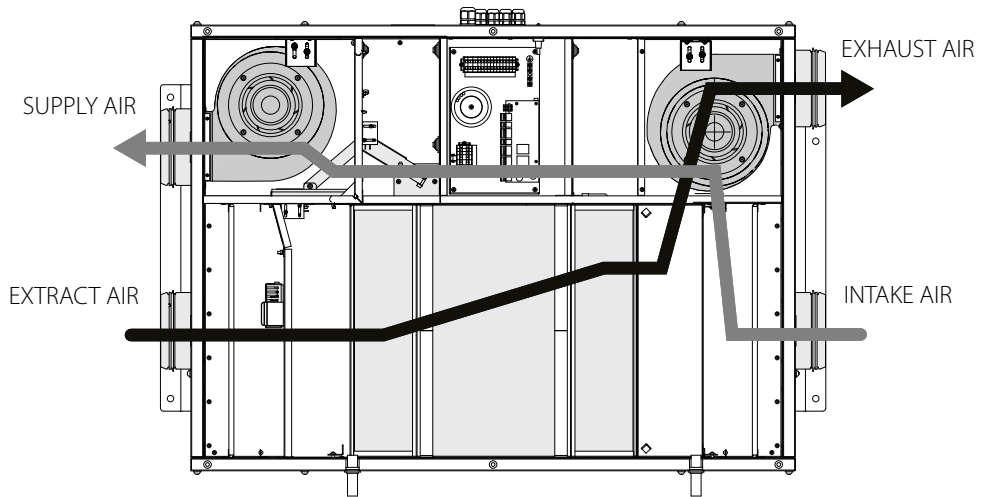

INSTALLATION AND SET-UP

HUMIDITY SENSOR MOUNTING

Remove the service panel and install the humidity sensor into the mount from the side of the extract air duct and connect the humidity sensor connector to the respective contact socket coming from the control unit.

HV2 sensor:

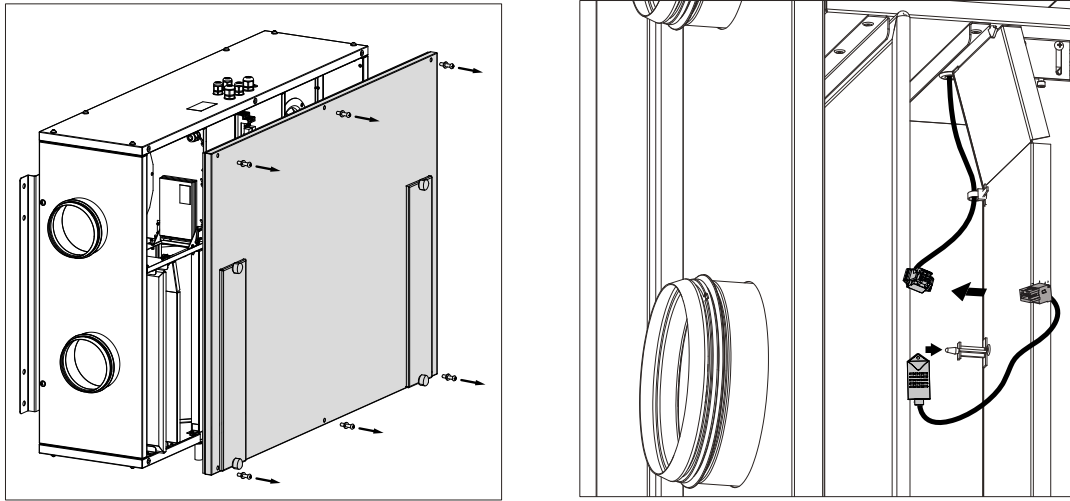

Install the service panel back to the unit.

UNIT INSTALLATION

To attain the best performance of the unit and to minimise turbulence-induced air pressure losses connect the straight air duct section to the spigots on both sides of the unit while mounting.

Minimum straight air duct length:

- equal to 1 air duct diameter on the intake side
- equal to 3 air duct diameters on the outlet side

If the air ducts are too short or not connected, protect the unit parts from ingress of foreign objects. To prevent uncontrollable access to the fans, the spigots may be covered with a protecting grille or other protecting device with mesh width not more than 12.5 mm.

While installing the unit, ensure convenient access for subsequent maintenance and repair.

Fasteners for ceiling mounting are not included in the delivery set and should be ordered separately. While choosing fasteners consider the material of the mounting surface as well as the weigh of the unit, refer to the Technical data section. Fasteners for unit installation should be selected by a qualified technician.

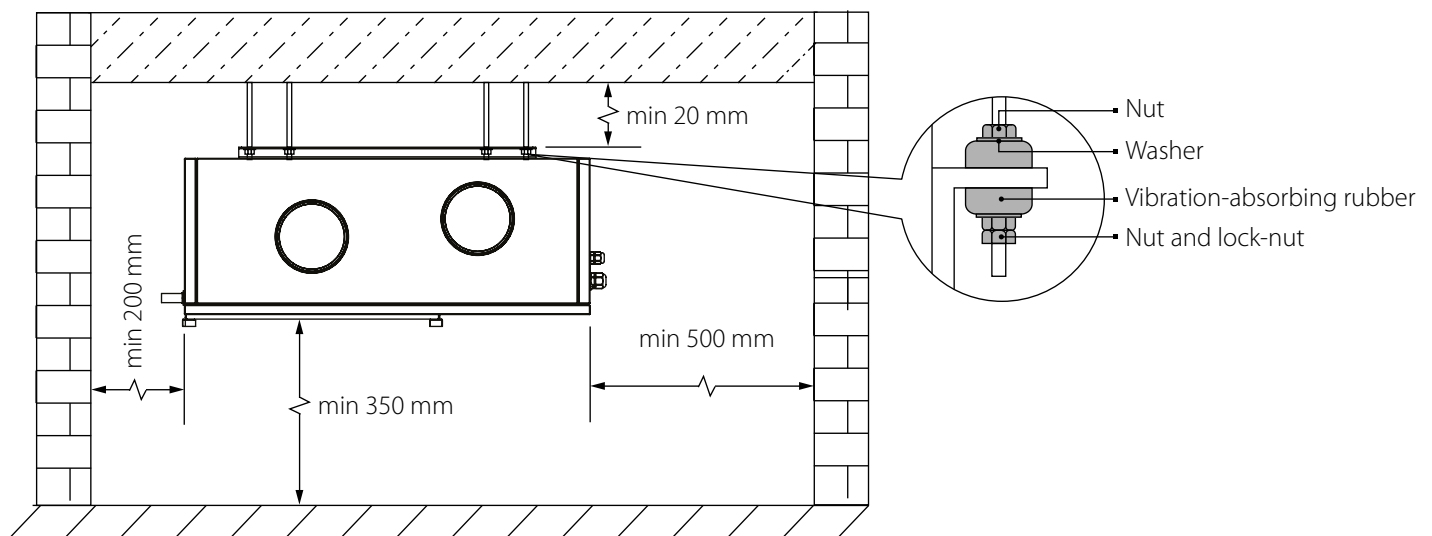

Wall and ceiling mounting examples

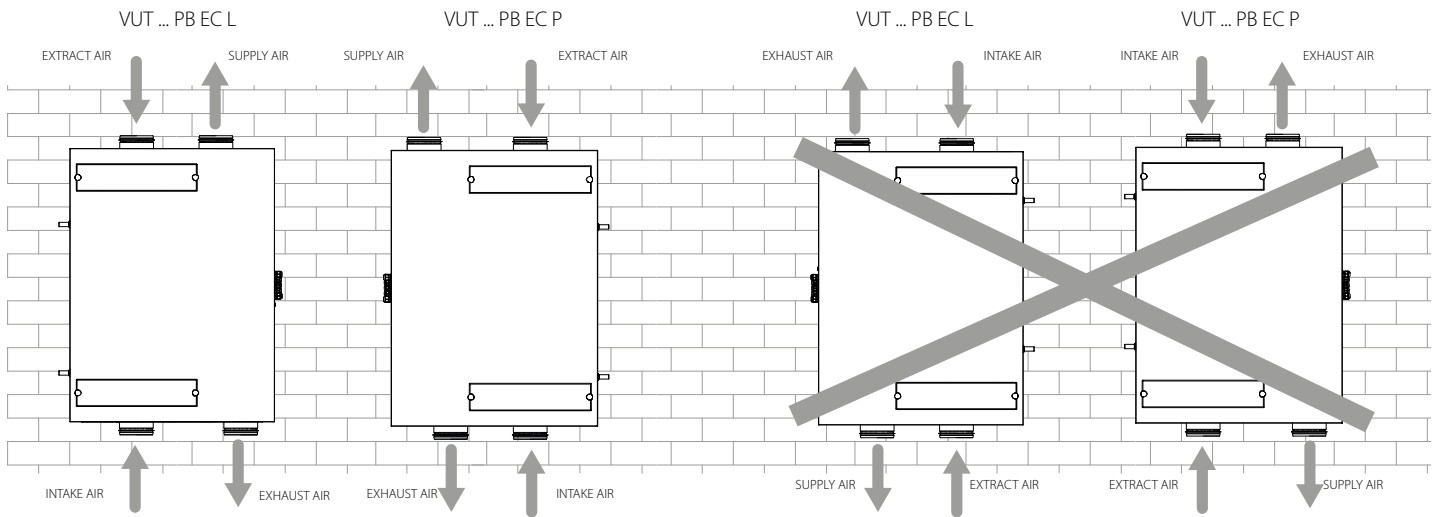
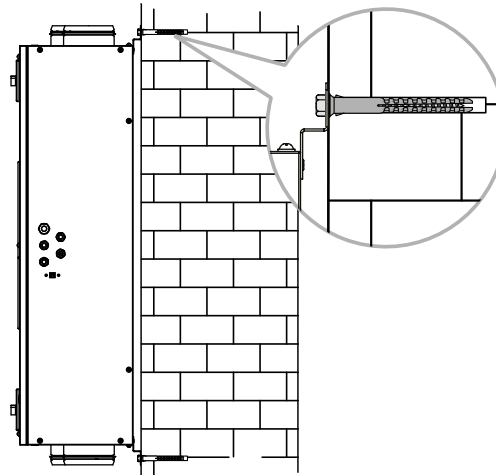

RIGHT-HANDED AND LEFT-HANDED MODIFICATIONS

The figure below shows the arrangement of spigots for left- and right-handed modifications. Choosing the right arrangement can improve the ease of installation, shorten the length of the ducts and reduce the number of air duct bends.

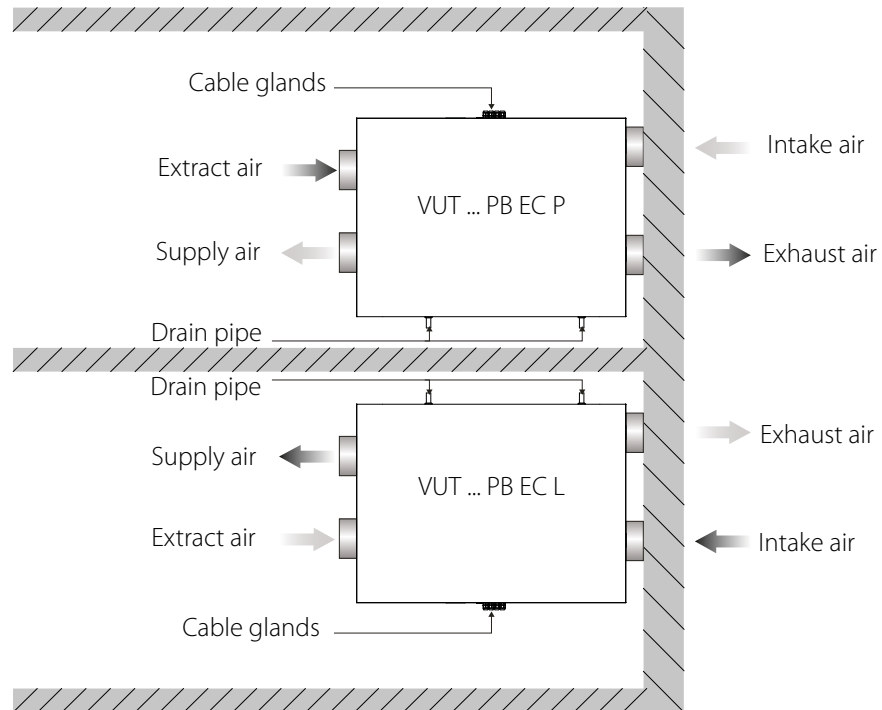

View from above

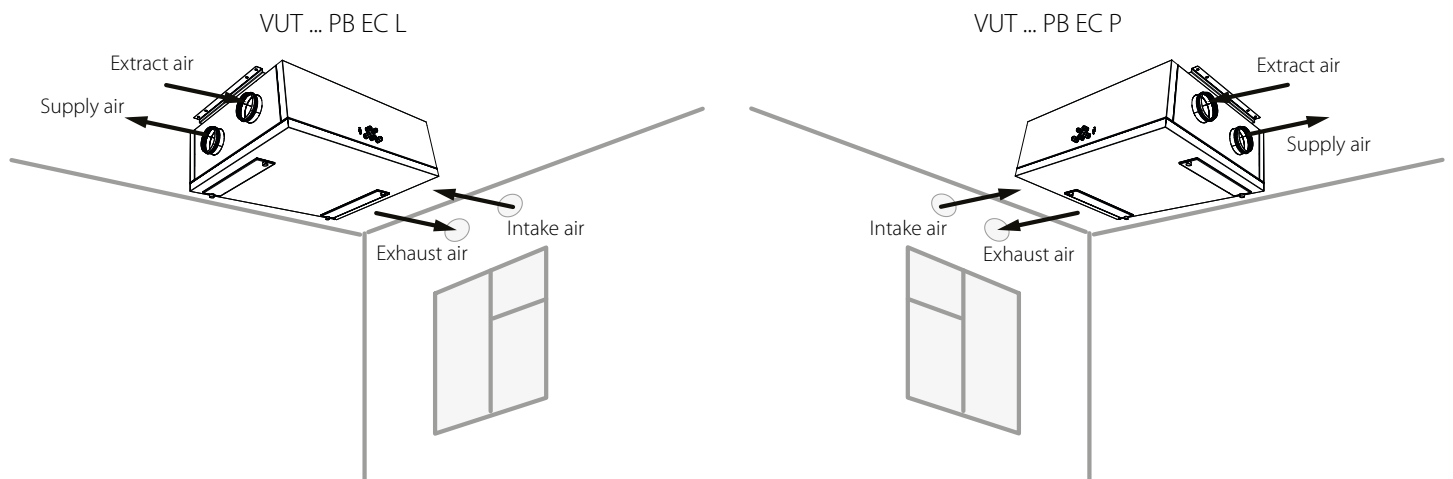

CONDENSATE DRAINAGE

Connect the drain pipe to the sewage system using the SFK 20x32 U-trap kit (available upon separate order). The pipe slope downwards must be at least 3°.

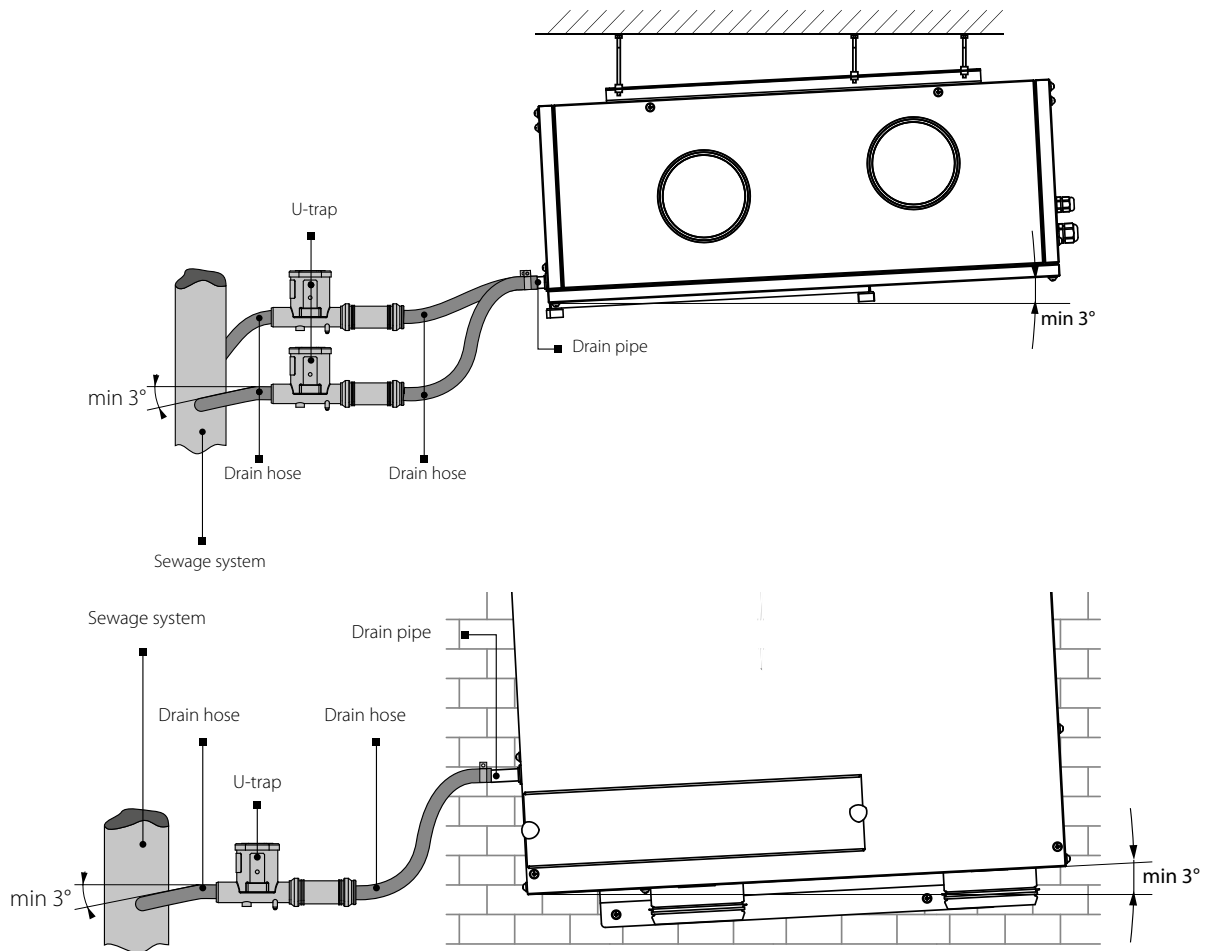

The condensate drainage system is designed for normal operation in premises with air temperatures above 0 °C! If the expected ambient air temperatures are below 0 °C, the condensate drainage system must be equipped with heat insulation and pre-heating facilities.

CONNECTION TO POWER MAINS



ANY TAMPERING WITH THE INTERNAL CONNECTIONS IS PROHIBITED AND WILL VOID THE WARRANTY.

- The unit is rated for connection to 1~230 V/50 (60) Hz power mains according to the wiring diagram.
 - The connection must be made using durable, insulated and heat-resistant conductors (cables, wires). The actual wire cross section selection must be based on the maximum load current, maximum conductor temperature depending in the wire type, insulation, length and installation method.
 - The external power input must be equipped with a automatic circuit breaker built into the stationary wiring to open the circuit in the event of overload or short-circuit. The position of the circuit breaker must ensure free access for quick unit power-off. The trip current of the automatic circuit breaker must exceed the maximum current consumption of the unit (refer to the "Technical data" section or to the unit label). The recommended trip current of the circuit breaker is the next current in the standard trip current row following the maximum current of the connected unit.
 - The automatic circuit breaker is not included in the delivery set and can be ordered separately.
- To access the control unit, remove the service panel.

External wiring diagram for VUT 160/250/350 PB EC A11 units

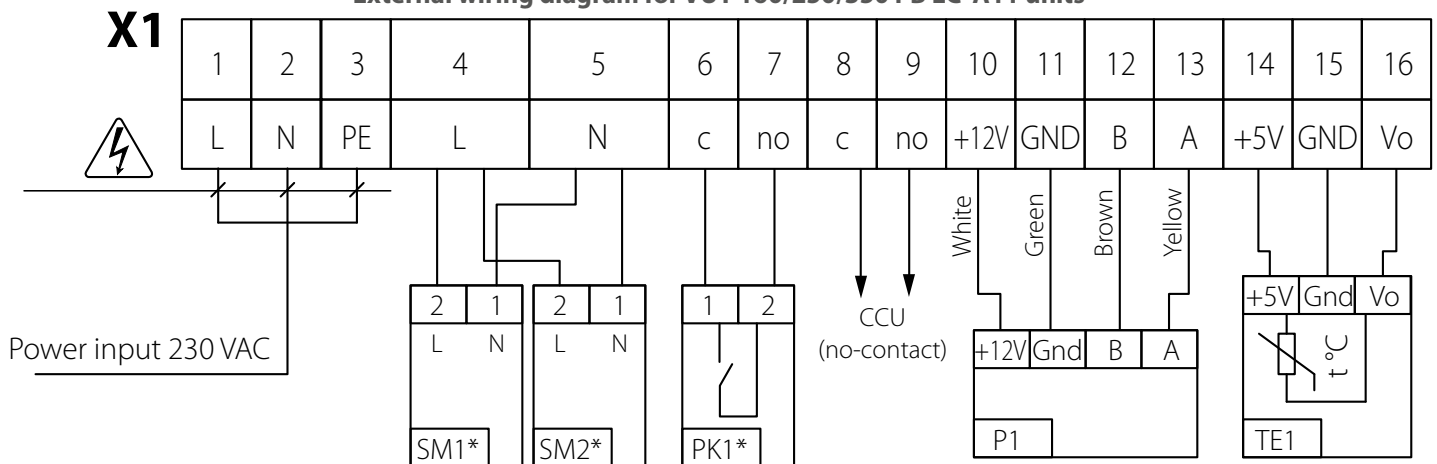

Designation	Name	Model	Wire**
CCU*	DX cooler	N0	2x0.75 mm ²
SM1*	Supply air damper actuator	LF 230	2x0.75 mm ²
SM2*	Extract air damper actuator	LF 230	2x0.75 mm ²
PK1*	Contact from a fire alarm panel	N0	2x0.75 mm ²
P1	Control panel		
TE1	Outdoor temperature sensor		The sensor is installed by the manufacturer in the intake air duct.

*Is not included in the delivery set

** Maximum connecting cable length is 20 m!



—ELECTRIC SHOCK HAZARD!

External wiring diagram for VUT 160/250/350 PB EC A14 units

The unit has an option of additional external controls connection to the X2 terminal block, which is located on the hinged electrical mounting plate of the control unit. Extra connections to the unit are shown in dotted lines in the External wiring diagram.

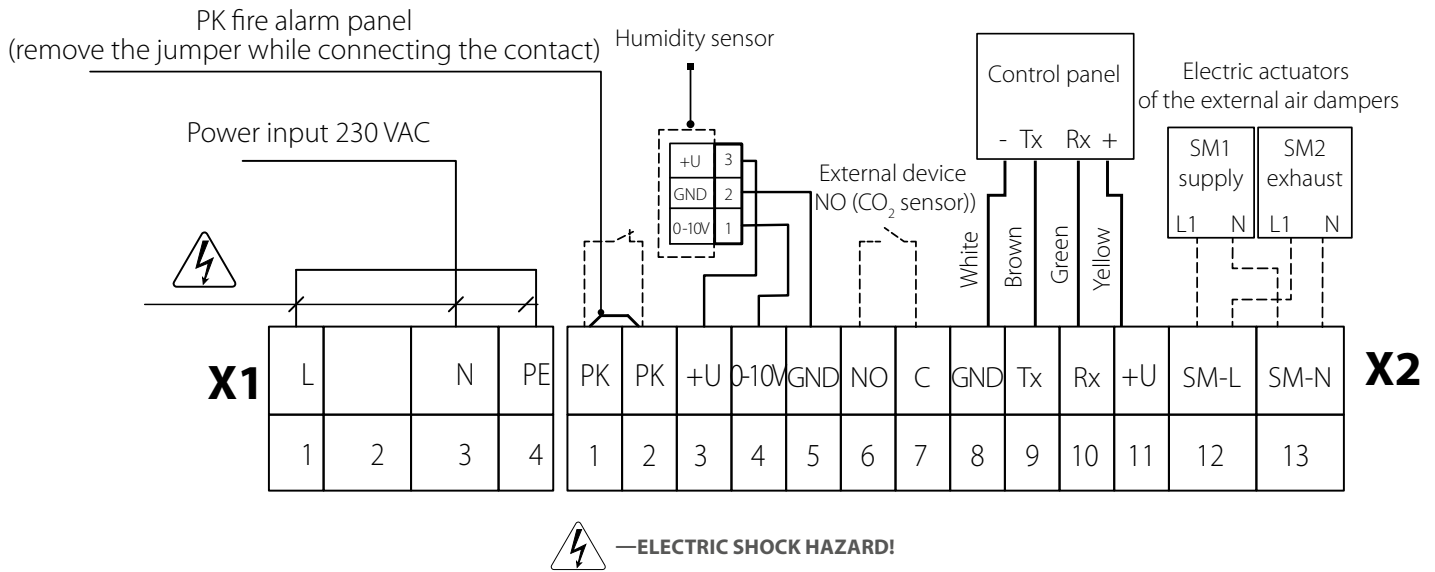
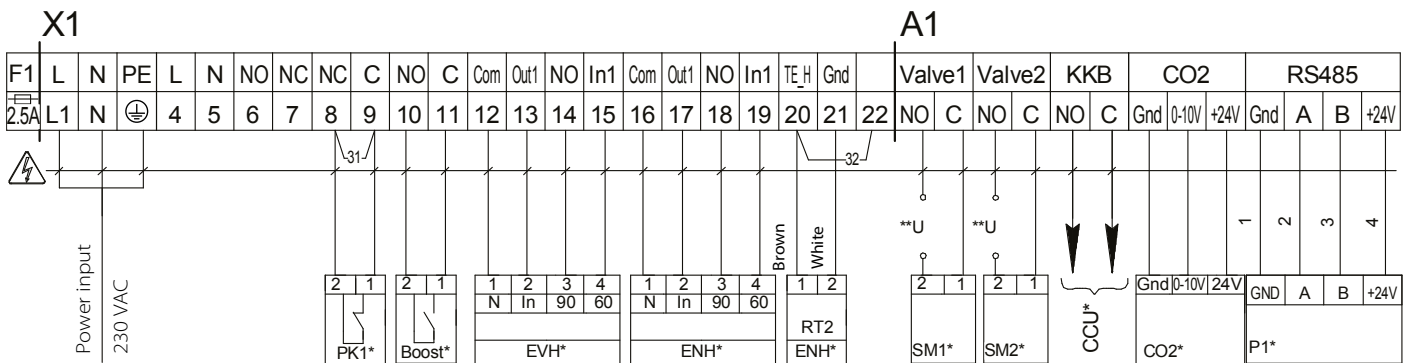
External wiring diagram for VUT 160/250/350 PB EC A21 units

Designation	Name	Wire***	Contact type	Note
SM1*	Supply air damper actuator	2 x 0,75 mm ²	NO	3 A, 30 V DC/~250 AC
SM2 *	Exhaust air damper actuator	2 x 0,75 mm ²	NO	3 A, 30 V DC/~250 AC
PK1*	Contact from fire alarm control panel	2 x 0,75 mm ²	NC	Remove 31 jumper
CCU*	Cooler control	2 x 0,75 mm ²	NO	3 A, 30 V DC/~250 AC
P1*	External control panel	4 x 0,5 mm ²		
Boost*	Contacts ON/OFF Boost	2 x 0,75 mm ²	NO	
CO2*	External CO2 sensor	3 x 0,25 mm ²	NO	
ENH*	Channel heater (afterheater)	4 x 0,5 mm ²		
ENH* RT2	Channel temperature sensor	2 x 0,25 mm ²		With ENH, Remove 32 jumper
EVH*	Channel heater (preheating)	4 x 0,5 mm ²		

*Not included in the delivery set.

** The U supply voltage of the SM1, SM2 external dampers is selected depending on the type of dampers.

*** Maximum connecting cable length is 20 m!

— **ELECTRIC SHOCK HAZARD!**

TECHNICAL MAINTENANCE

Maintenance operations of the unit are required 3-4 times per year. Maintenance includes general cleaning of the unit and the following operations:

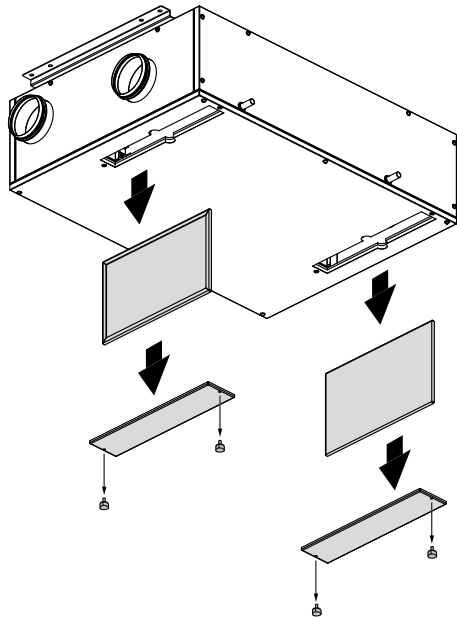

1. Filter maintenance (3-4 times per year).

Dirty filters increase air resistance in the system and reduce supply air volume. The filters require cleaning not less than 3-4 times per year. Vacuum cleaning is allowed. After two consecutive cleanings filters must be replaced. For new filters, contact the Seller. To clean or replace the filters, detach the removable plates located on the service side of the unit. After cleaning install the filters and the detachable plates in the reverse order.

2. Heat exchanger maintenance (once per year).

Some dust may accumulate on the heat exchanger even in case of regular maintenance of the filters. To maintain the high heat recovery efficiency, regular cleaning is required.

The heat exchanger is connected with the drain pan by the fixing bands that should be removed only in case of heat exchanger replacement.

The drain pan is fixed to the unit casing using three screws.

To clean the heat exchanger pull it and the drain pan out, drain the water through the pipes, then flush the heat exchanger with warm detergent solution. After cleaning install the dry heat exchanger with the drain pan back to the unit.

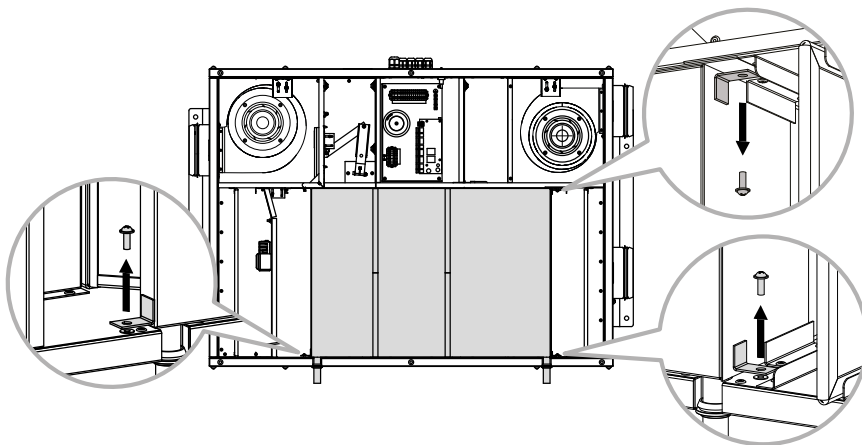
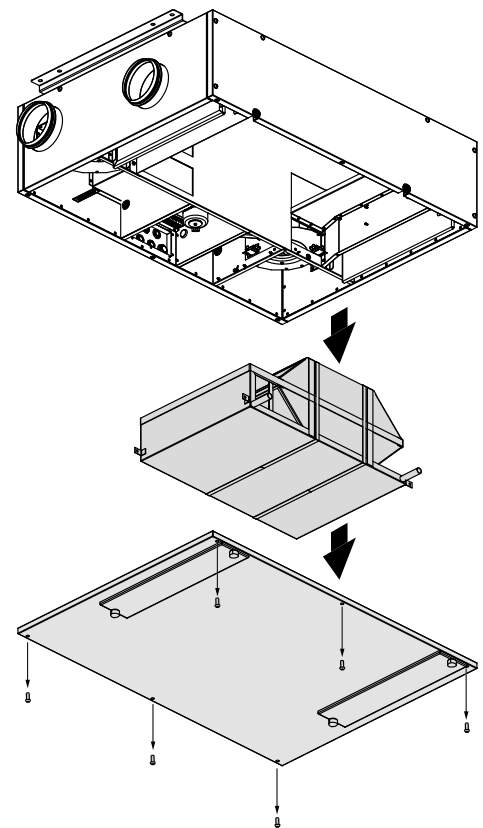

3. Fan maintenance (once per year).

Even in case of regular maintenance of the filters, some dust may accumulate inside the fans and reduce the fan performance and supply air flow. Clean the fans with a soft brush or cloth. Do not use water, aggressive solvents, or sharp objects as they may damage the impeller.

4. Technical maintenance of condensate drainage system (once a year).

The condensate drainage (drain line) may get clogged by dirt and dust particles contained in the exhaust air. Pour some water inside the drain pan to check the pipe for clogging. Clean the U-trap and the drain pipe if required.

5. Ductwork system maintenance (once in 5 years).

Even regular fulfilling of all the maintenance operations prescribed above may not completely prevent dirt accumulation in the air ducts, which leads to air pollution and reduces the unit capacity. Duct maintenance means regular cleaning or replacement.

6. Control unit maintenance (if necessary).

The control unit is positioned inside the unit casing. For accessing the control unit remove the fixing screws on the service panel and remove it.

CAUTION! The control unit maintenance must be performed by an expert qualified for unassisted operations with electrical installations with the voltage up to 1000 V after careful reading of the user's manual.

TROUBLESHOOTING		
Problem	Possible reasons	Troubleshooting
The fan(s) do(es) not get started.	No power supply.	Make sure the power supply line is connected correctly, otherwise troubleshoot a connection error.
Low air flow.	Filters, fans or the heat exchanger are soiled.	Clean or replace the filters, clean the fans, and the heat exchanger.
	The ventilation system is soiled or damaged.	Make sure the air ducts are clean and intact.
Noise, vibration.	The fan impeller is soiled.	Clean the impellers.
	Fan screw connection is loose.	Check tightening torques.
Water leakage.	The drainage system is soiled, damaged, or installed incorrectly.	Clean the drain line if necessary. Check the drain line slope angle. Make sure that the U-trap is filled with water and the drain pipes are frost protected.

STORAGE AND TRANSPORTATION REGULATIONS

- Store the unit in the manufacturer's original packaging box in a dry closed ventilated premise with temperature range from +5 °C to +40 °C and relative humidity up to 70 %.
- Storage environment must not contain aggressive vapors and chemical mixtures provoking corrosion, insulation, and sealing deformation.
- Use suitable hoist machinery for handling and storage operations to prevent possible damage to the unit.
- Follow the handling requirements applicable for the particular type of cargo.
- The unit can be carried in the original packaging by any mode of transport provided proper protection against precipitation and mechanical damage. The unit must be transported only in the working position.
- Avoid sharp blows, scratches, or rough handling during loading and unloading.
- Prior to the initial power-up after transportation at low temperatures, allow the unit to warm up at operating temperature for at least 3-4 hours.

MANUFACTURER'S WARRANTY

The product is in compliance with EU norms and standards on low voltage guidelines and electromagnetic compatibility. We hereby declare that the product complies with the provisions of Electromagnetic Compatibility (EMC) Directive 2014/30/EU of the European Parliament and of the Council, Low Voltage Directive (LVD) 2014/35/EU of the European Parliament and of the Council and CE-marking Council Directive 93/68/EEC. This certificate is issued following test carried out on samples of the product referred to above.

The manufacturer hereby warrants normal operation of the unit for 24 months after the retail sale date provided the user's observance of the transportation, storage, installation, and operation regulations. Should any malfunctions occur in the course of the unit operation through the Manufacturer's fault during the guaranteed period of operation, the user is entitled to get all the faults eliminated by the manufacturer by means of warranty repair at the factory free of charge. The warranty repair includes work specific to elimination of faults in the unit operation to ensure its intended use by the user within the guaranteed period of operation. The faults are eliminated by means of replacement or repair of the unit components or a specific part of such unit component.

The warranty repair does not include:

- routine technical maintenance
- unit installation/dismantling
- unit setup

To benefit from warranty repair, the user must provide the unit, the user's manual with the purchase date stamp, and the payment paperwork certifying the purchase. The unit model must comply with the one stated in the user's manual. Contact the Seller for warranty service.

The manufacturer's warranty does not apply to the following cases:

- User's failure to submit the unit with the entire delivery package as stated in the user's manual including submission with missing component parts previously dismantled by the user.
- Mismatch of the unit model and the brand name with the information stated on the unit packaging and in the user's manual.
- User's failure to ensure timely technical maintenance of the unit.
- External damage to the unit casing (excluding external modifications as required for installation) and internal components caused by the user.
- Redesign or engineering changes to the unit.
- Replacement and use of any assemblies, parts and components not approved by the manufacturer.
- Unit misuse.
- Violation of the unit installation regulations by the user.
- Violation of the unit control regulations by the user.
- Unit connection to power mains with a voltage different from the one stated in the user's manual.
- Unit breakdown due to voltage surges in power mains.
- Discretionary repair of the unit by the user.
- Unit repair by any persons without the manufacturer's authorization.
- Expiration of the unit warranty period.
- Violation of the unit transportation regulations by the user.
- Violation of the unit storage regulations by the user.
- Wrongful actions against the unit committed by third parties.
- Unit breakdown due to circumstances of insuperable force (fire, flood, earthquake, war, hostilities of any kind, blockades).
- Missing seals if provided by the user's manual.
- Failure to submit the user's manual with the unit purchase date stamp.
- Missing payment paperwork certifying the unit purchase.



FOLLOWING THE REGULATIONS STIPULATED HEREIN WILL ENSURE A LONG AND TROUBLE-FREE OPERATION OF THE UNIT



USER'S WARRANTY CLAIMS SHALL BE SUBJECT TO REVIEW ONLY UPON PRESENTATION OF THE UNIT, THE PAYMENT DOCUMENT AND THE USER'S MANUAL WITH THE PURCHASE DATE STAMP

CERTIFICATE OF ACCEPTANCE

Unit Type	Heat recovery air handling unit
Model	
Serial Number	
Manufacture Date	
Quality Inspector's Stamp	

SELLER INFORMATION

Seller	
Address	
Phone Number	
E-mail	
Purchase Date	
This is to certify acceptance of the complete unit delivery with the user's manual. The warranty terms are acknowledged and accepted.	
Customer's Signature	

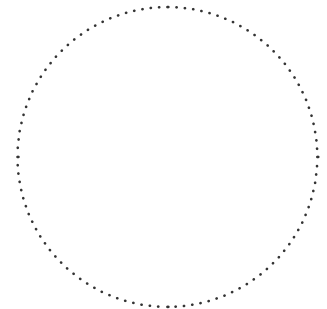

Seller's Stamp

INSTALLATION CERTIFICATE

The _____ unit is installed pursuant to the requirements stated in the present user's manual.	
Company name	
Address	
Phone Number	
Installation Technician's Full Name	
Installation Date:	Signature:
The unit has been installed in accordance with the provisions of all the applicable local and national construction, electrical and technical codes and standards. The unit operates normally as intended by the manufacturer.	
Signature:	

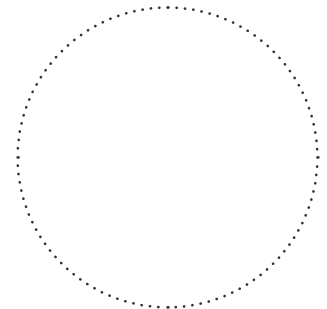

Installation Stamp

WARRANTY CARD

Unit Type	Heat recovery air handling unit
Model	
Serial Number	
Manufacture Date	
Purchase Date	
Warranty Period	
Seller	

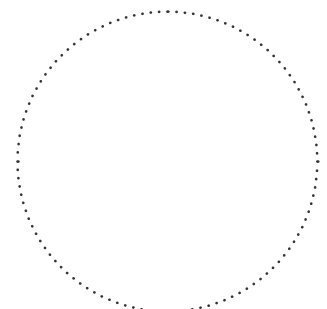

Seller's Stamp

