

Series
VENTS VUT/VUE VB EC



Air handling units in heat- and sound-insulated casing.
Air flow up to **690 m³/h**.
Heat recovery efficiency up to **93 %**

Description

The air-handling units are the fully featured ventilation units with heat recovery for air filtration, fresh air supply and stale air extraction.

Casing

Made of high-quality polymer coated steel, internally filled with mineral wool layer for heat and sound insulation.

Filter

Supply and exhaust air flows are purified through panel filters with filtering class G4 and F7, respectively. Filters with G4 filtering class are used for supply and exhaust air purification in the **VUT/VUE 250 VB EC** units. F7 filter is available as an option for supply air filtration.

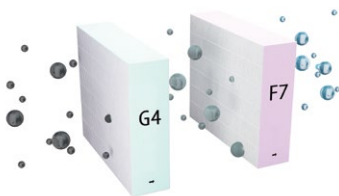

Fans

The units are equipped with high-efficient EC motors with an external rotor and a centrifugal impeller with backward curved blades.

Heat exchanger

The **VUT V(B) EC** units are equipped with a counter-flow polystyrene heat exchanger.

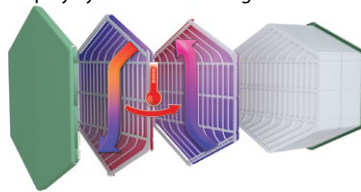

The **VUE V(B) EC** units are equipped with a counter-flow enthalpy heat exchanger.

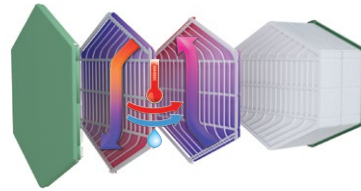

Bypass

The **VUT/VUE VB EC** units are equipped with a bypass for summer cooling.

Automation

The **VUT/VUE V(B) EC A21** units are equipped with a built-in automation system. The A21 controller allows integrating the unit into the Smart Home system or BMS (Building Management Systems). To control the unit via Wi-Fi, download the VENTS Home mobile app.

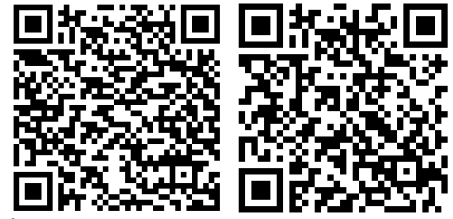

Google play

Download on the App Store



The **VUT/VUE V(B) EC A14** units have an integrated control system with a wall-mounted control panel A14 with a LED indication.

Frost protection

In the **VUT/VUE 160/350/550 VB EC A21** units it is possible to connect a preheater to protect the unit from freezing.

The **VUT 250 VBE EC A21** unit is equipped with a built-in preheater for frost protection.

Mounting

The units are designed for wall or floor mounting. Access for maintenance of units and filters is possible from the right and left sides.

Overall dimensions

Model	Dimensions [mm]			
	Ø D	B	H	L
VUT/VUE 160 V EC	125	330	550	600
VUT/VUE 160 V1 EC	125	370	590	640
VUT/VUE 160 VB EC	125	330	580	600
VUT/VUE 160 V1B EC	125	370	620	640
VUT/VUE 250 VB EC L/R	160	560	970	560
VUT/VUE 350 VB EC	160	583	675	730
VUT/VUE 350 V1B EC	160	470	675	730
VUT/VUE 550 VB EC	200	720	675	823

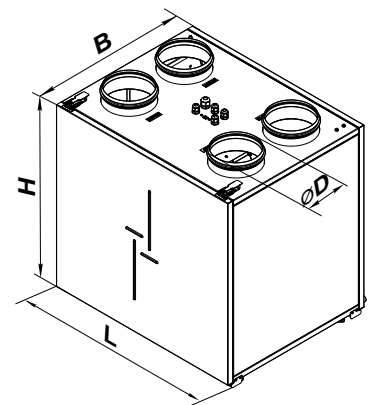





Designation key

Series	Rated air flow [m ³ /h]	Installation features	Casing design	Bypass	Motor type	Service side*	Control
VUT: ventilation with heat recovery VUE: ventilation with energy recovery	160, 250, 350, 550	V: vertical	- by default 1: casing modification	_ : without bypass B: with bypass	EC: synchronous electronically commutated motor	L: left R: right	A14 A21

* Only for VUT 250 VB EC L/R

Control and automation

Functions	A21	A14
Wired remote control panel	Option (A22) 	A14 
Control via a wired remote LCD control panel	Option (A25) 	-
Wireless remote control panel	Option (A22 Wi-Fi) 	-
BMS	RS-485 Wi-Fi Ethernet MODBUS (RTU, TCP)	-
Vents Cloud Server service	+	-
Control via Wi-Fi using a mobile application	+	-
Frost protection	+	+
Bypass	Auto + manual	Manual
Week-scheduled operation	+	-
Filter replacement indication	By the filter timer	By the filter timer
	According to filter clogging differential pressure switch readings (only for VUT/VUE 550 VB EC A21)	
Alarm indication	+	+
Speed selection	+	+
Timer	+	-
RH% sensor	Option	Option
CO ₂ sensor	Option	Option
VOC sensor	Option	Option
PM2.5 sensor	Option	Option
Boost mode	+	-
Fireplace mode	+	-
Preheater connection	Option (built-in preheater in VUT 250 VBE EC units)	-
Reheater connection	Option	-
Fire alarm sensor	Option	Option
Minimum supply air temperature control	+	-

Unit design

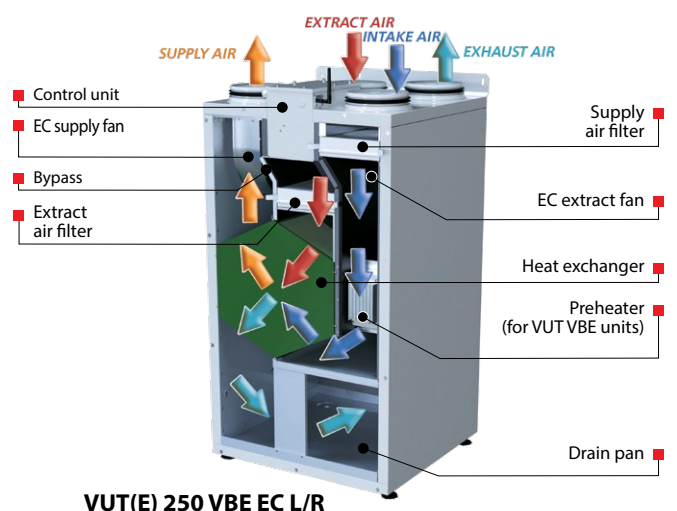
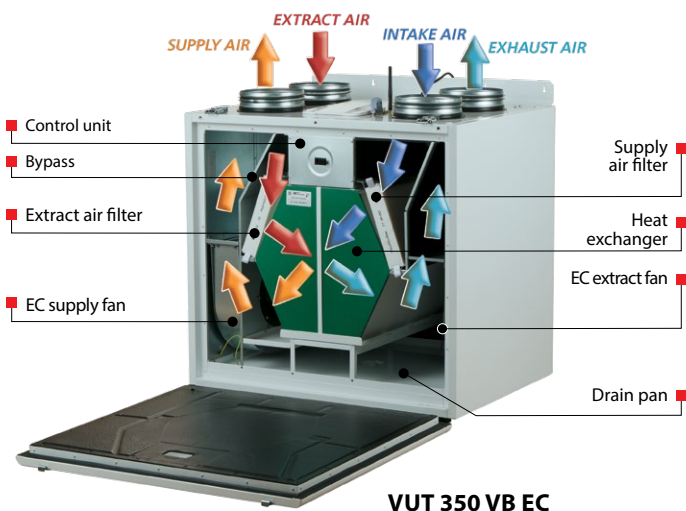

AIR HANDLING UNITS WITH HEAT RECOVERY

Technical data

	VUT 160 VB EC	VUE 160 VB EC	VUT 160 V1B EC	VUE 160 V1B EC
Unit voltage [V/50 (60) Hz]	1~230			
Maximum power [W]	57			
Maximum current [A]	0.5			
Maximum air flow [m³/h]	200			
Sound pressure level at 3 m distance [dBA]	24		22	
Transported air temperature [°C]	-25...+40			
Casing material	painted steel			
Insulation	20 mm mineral wool		40 mm mineral wool	
Extract filter	G4			
Supply filter	F7 (G4 – option)			
Connected air duct diameter [mm]	Ø125			
Weight [kg]	36		44	
Heat recovery efficiency [%]	85–93	76–92	85–93	76–92
Heat exchanger type	counter-flow			
Heat exchanger material	polystyrene	enthalpy membrane	polystyrene	enthalpy membrane
Energy efficiency class for A14, A21	A+	A	A+	A

VENTS VUT/VUE VB EC

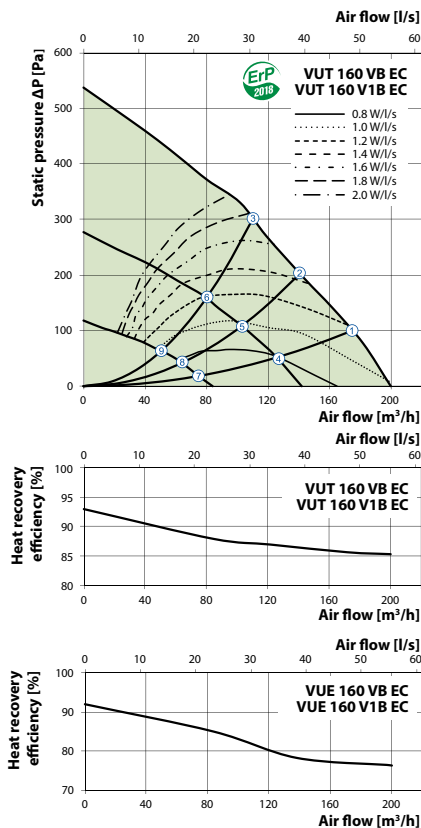

VUT 160 VB EC, VUE 160 VB EC

A-weighted sound power level	Gen. dBA	Octave frequency band [Hz]								LpA, 3 m dBA	LpA, 1 m dBA	
		63	125	250	500	1000	2000	4000	8000			
L _{WA} to supply air inlet	dBA	52	28	46	49	41	35	33	36	29		
L _{WA} to supply air outlet	dBA	60	32	52	58	47	37	36	41	35		
L _{WA} to exhaust air inlet	dBA	51	27	45	49	41	36	32	35	29		
L _{WA} to exhaust air outlet	dBA	60	31	50	59	48	36	36	41	32		
L _{WA} to environment	dBA	45	25	41	42	34	31	28	27	22	24	34

VUT 160 V1 EC, VUE 160 V1 EC, VUT 160 V1B EC, VUE 160 V1B EC

A-weighted sound power level	Gen. dBA	Octave frequency band [Hz]								LpA, 3 m dBA	LpA, 1 m dBA	
		63	125	250	500	1000	2000	4000	8000			
L _{WA} to supply air inlet	dBA	52	28	46	49	41	35	33	36	29		
L _{WA} to supply air outlet	dBA	60	32	52	58	47	37	36	41	35		
L _{WA} to exhaust air inlet	dBA	51	27	45	49	41	36	32	35	29		
L _{WA} to exhaust air outlet	dBA	60	31	50	59	48	36	36	41	32		
L _{WA} to environment	dBA	43	23	39	39	33	29	25	25	20	22	32

Calculation of air temperature at heat exchanger outlet:

$$t = t_{\text{outd}} + k_{\text{hr}} * (t_{\text{extr}} - t_{\text{outd}}) / 100,$$

where

t_{outd} is outdoor air temperature [°C]

t_{extr} is extract air temperature [°C]

k_{hr} is heat exchanger efficiency (according to the diagram) [%]

Technical data

	VUT 250 VB EC L/R	VUE 250 VB EC L/R	VUT 250 VBE EC L/R	VUE 250 VBE EC L/R
Unit voltage [V/50 (60) Hz]	1~230			
Maximum power [W]	180			
Maximum current [A]	1.37			
Electric heater power [W]	-	-	1400	
Electric heater current [A]	-	-	6.09	
Maximum unit power with an electric heater [W]	180	-	1580	
Maximum unit current (with an electric heater) [A]	1.37	-	7.46	
Maximum air flow [m³/h]	390			
Sound pressure level at 3 m distance [dBA]	35			
Transported air temperature [°C]	-25...+40			
Casing material	painted steel			
Insulation	30 mm mineral wool			
Extract filter	G4			
Supply filter	G4 (F7 – option)			
Connected air duct diameter [mm]	Ø160			
Weight [kg]	66			
Heat recovery efficiency [%]	88–95	78–90	88–95	78–90
Heat exchanger type	counter-flow			
Heat exchanger material	polystyrene	enthalpy membrane	polystyrene	enthalpy membrane
Energy efficiency class for A14, A21	A+	A	A+	A

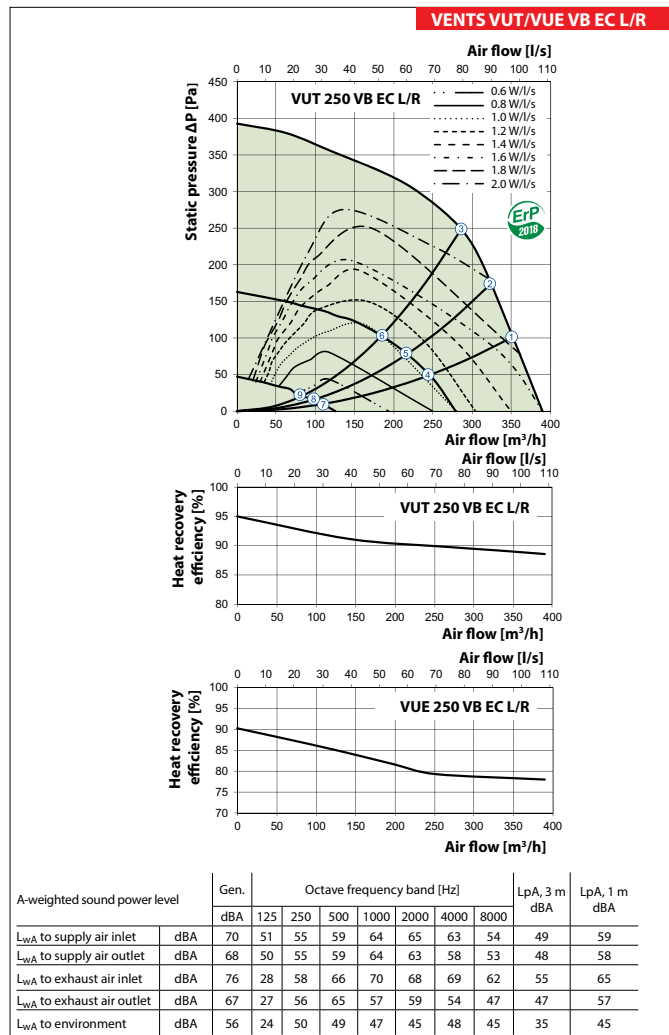

AIR HANDLING UNITS WITH HEAT RECOVERY

Technical data

	VUT 350 V1B EC	VUE 350 V1B EC	VUT 350 VB EC	VUE 350 VB EC
Unit voltage [V/50 (60) Hz]	1~230		1~230	
Maximum power [W]	169		178	
Maximum current [A]	1.3		1.4	
Maximum air flow [m³/h]	420		450	
Sound pressure level at 3 m distance [dBA]	28		28	
Transported air temperature [°C]	-25...+40		-25...+40	
Casing material	painted steel		painted steel	
Insulation	40 mm mineral wool		40 mm mineral wool	
Extract filter	G4		G4	
Supply filter	F7 (G4 – option)		F7 (G4 – option)	
Connected air duct diameter [mm]	Ø160		Ø160	
Weight [kg]	57		64	
Heat recovery efficiency [%]	85–92	74–91	85–92	73–91
Heat exchanger type	counter-flow		counter-flow	
Heat exchanger material	polystyrene	enthalpy membrane	polystyrene	enthalpy membrane
Energy efficiency class for A14, A21	A+	A	A+	A

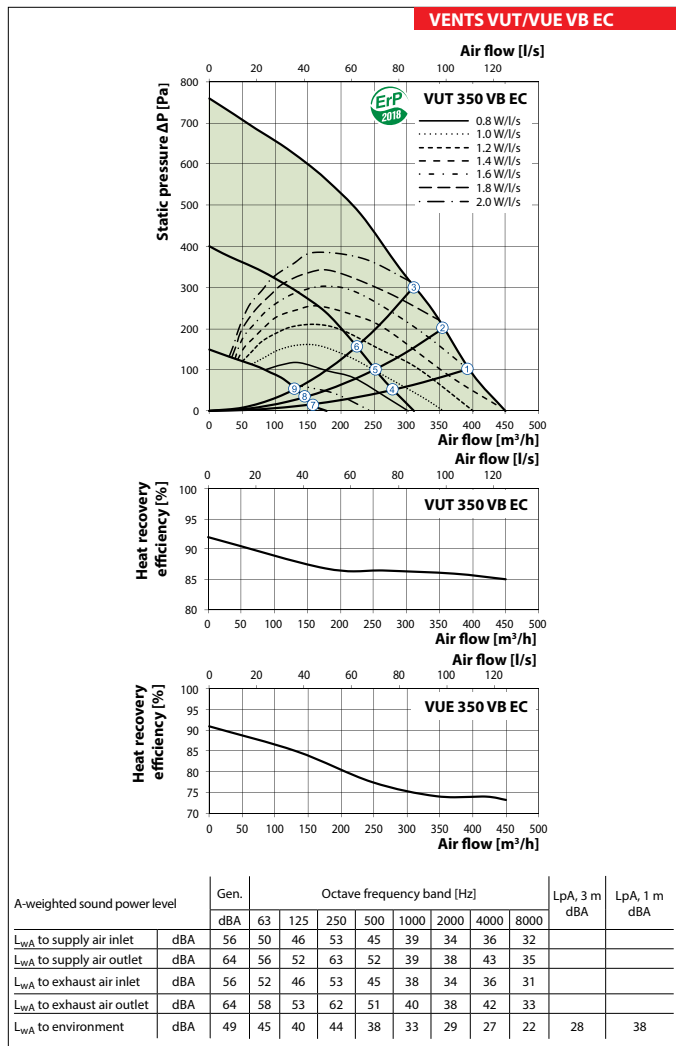
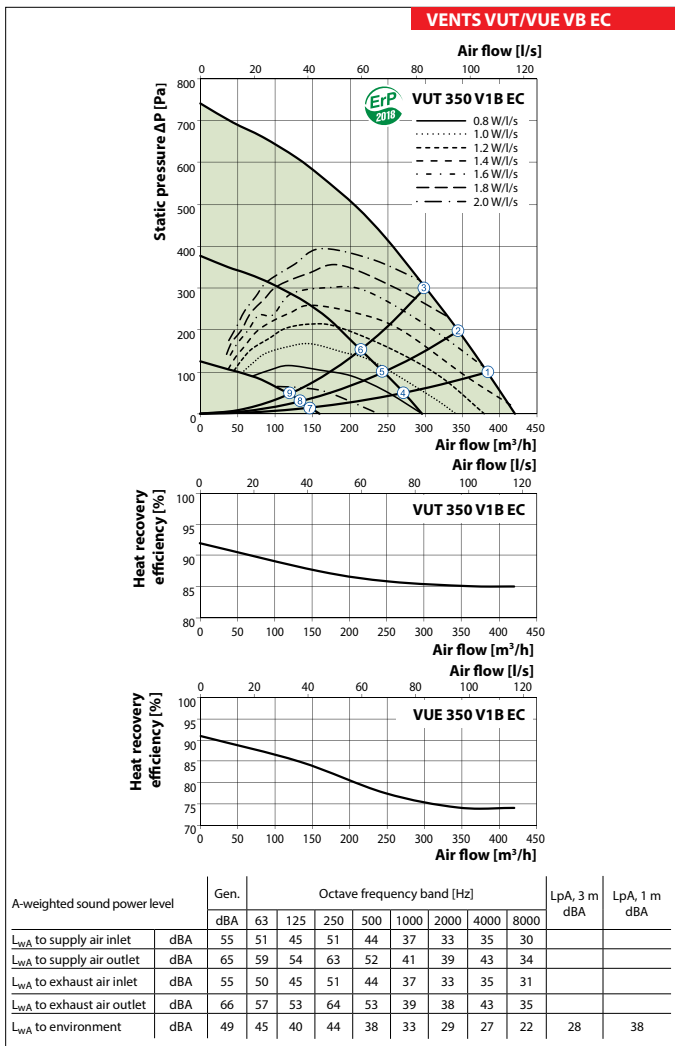

Technical data

	VUT 550 VB EC	VUE 550 VB EC
Unit voltage [V/50 (60) Hz]		1~230
Maximum power [W]		350
Maximum current [A]		2.4
Maximum air flow [m ³ /h]		692
Sound pressure level at 3 m distance [dBA]		38
Transported air temperature [°C]		-25...+40
Casing material		painting steel
Insulation		40 mm mineral wool
Extract filter		G4
Supply filter		F7 (G4 – option)
Connected air duct diameter [mm]		Ø200
Weight [kg]		82
Heat recovery efficiency [%]	84–92	73–91
Heat exchanger type		counter-flow
Heat exchanger material	polystyrene	enthalpy membrane
Energy efficiency class for A14, A21	A+	A

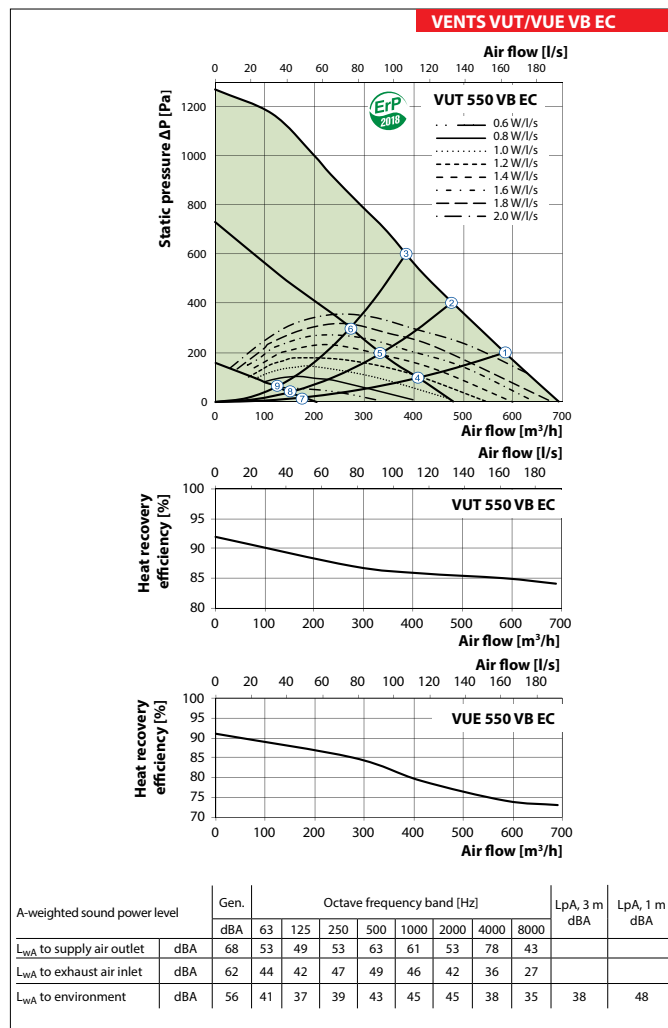

Technical data

VUT 350 VB EC			
Outlet spigot configuration	Air flow [l/s]	Specific power input [W/l/s]	Heat exchange efficiency [%]
Kitchen + 1 additional room with high level of humidity	21	0.71	88
Kitchen + 2 additional rooms with high levels of humidity	29	0.64	88
Kitchen + 3 additional rooms with high levels of humidity	37	0.68	87
Kitchen + 4 additional rooms with high levels of humidity	45	0.76	86
Kitchen + 5 additional rooms with high levels of humidity	53	0.86	86
Kitchen + 6 additional rooms with high levels of humidity	61	1.07	85
Kitchen + 7 additional rooms with high levels of humidity	69	1.26	85

VUT 550 VB EC			
Outlet spigot configuration	Air flow [l/s]	Specific power input [W/l/s]	Heat exchange efficiency [%]
Kitchen + 1 additional room with high level of humidity	21	0.71	87
Kitchen + 2 additional rooms with high levels of humidity	29	0.63	88
Kitchen + 3 additional rooms with high levels of humidity	37	0.63	88
Kitchen + 4 additional rooms with high levels of humidity	45	0.72	88
Kitchen + 5 additional rooms with high levels of humidity	53	0.84	88
Kitchen + 6 additional rooms with high levels of humidity	61	0.98	87
Kitchen + 7 additional rooms with high levels of humidity	69	1.16	87

Point	Power [W]				
	VUT 160 VB EC VUT 160 V1B EC VUE 160 VB EC VUE 160 V1B EC	VUT 250 VB EC L/R VUE 250 VB EC L/R	VUT 350 V1B EC VUE 350 V1B EC	VUT 350 VB EC VUE 350 VB EC	VUT 550 VB EC VUE 550 VB EC
1	57	180	168	177	345
2	56	179	166	175	349
3	54	168	162	170	349
4	28	63	65	71	131
5	27	57	64	71	131
6	26	52	62	69	131
7	14	15	18	21	22
8	13	15	17	21	22
9	13	14	17	21	22

Point	Sound pressure level at 3 m (1 m) distance, dB(A)				
	VUT 160 VB EC VUT 160 V1B EC VUE 160 VB EC VUE 160 V1B EC	VUT 250 VB EC L/R VUE 250 VB EC L/R	VUT 350 V1B EC VUE 350 V1B EC	VUT 350 VB EC VUE 350 VB EC	VUT 550 VB EC VUE 550 VB EC
1	24 (34)	35 (45)	28 (38)	28 (38)	38 (48)
2	23 (33)	35 (45)	27 (37)	27 (37)	36 (45)
3	23 (33)	35 (45)	27 (37)	27 (37)	36 (45)
4	20 (30)	24 (34)	23 (33)	23 (33)	27 (37)
5	20 (30)	24 (34)	22 (32)	22 (32)	27 (37)
6	20 (30)	23 (33)	22 (32)	22 (32)	27 (37)
7	13 (23)	18 (27)	15 (25)	15 (25)	17 (26)
8	13 (23)	17 (27)	14 (24)	14 (24)	17 (27)
9	13 (23)	17 (27)	14 (24)	14 (24)	17 (27)

Application options

Ventilation hood



Ceiling connector with a disk valve

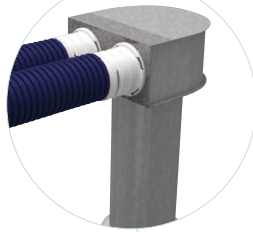

Isovent 150 insulated air duct

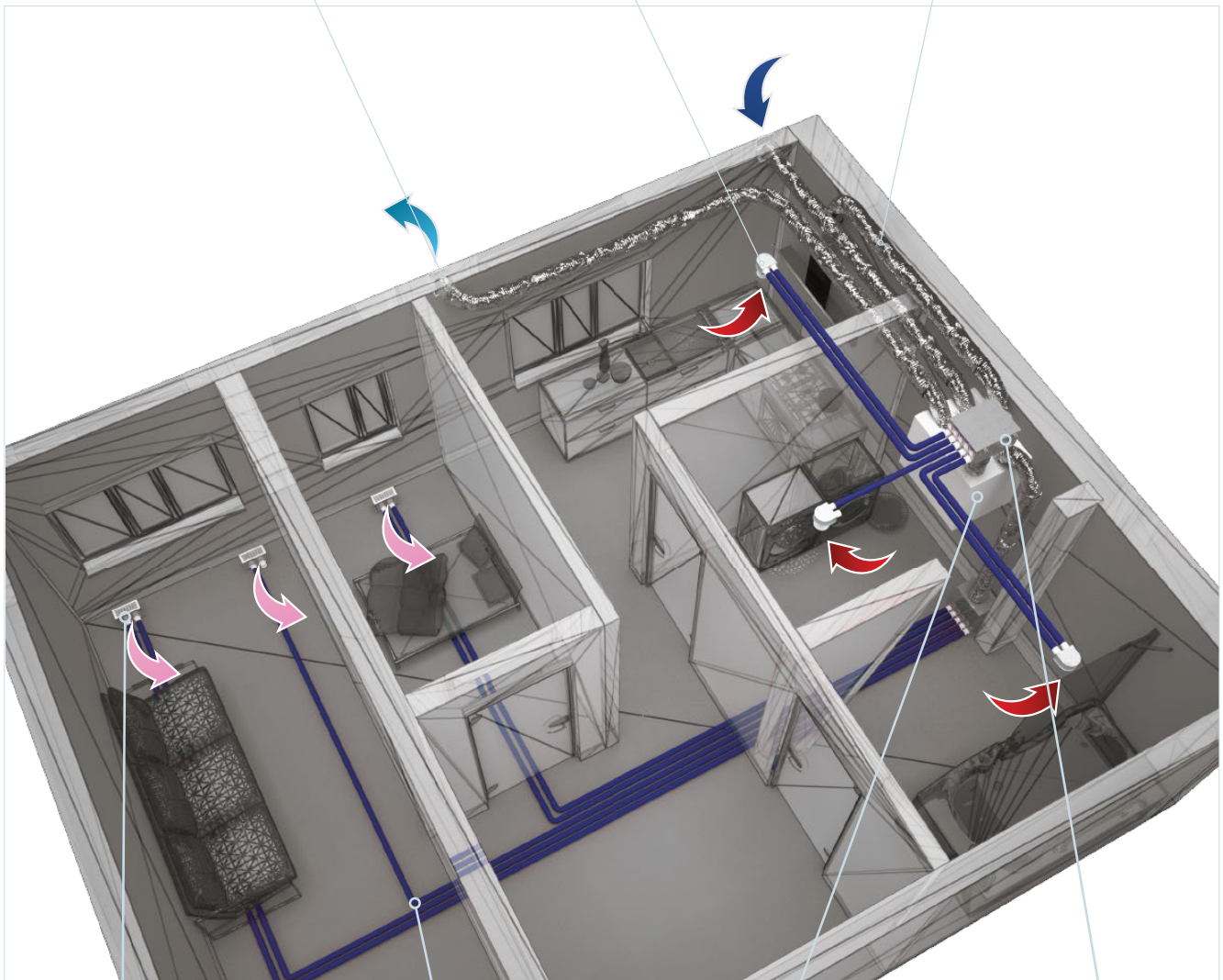

Floor connector with a grille

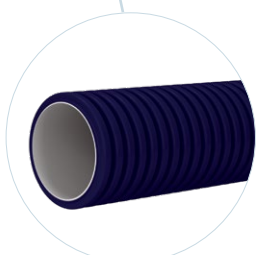

FlexiVent air duct





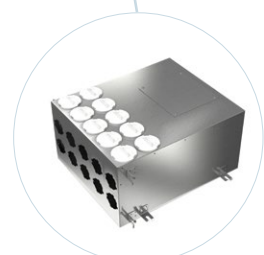





Air handling unit



Manifold

Accessories for air handling units

Model	G4 panel supply filter	G4 panel exhaust filter	F7 panel supply filter	LCD control panel	Control panel	Control panel with Wi-Fi	Indoor humidity sensor	CO ₂ sensor with indication	CO ₂ sensor
									
VUT 160 VB EC A21	SF 285x195x10 G4		SF 285x195x10 F7	A25	A22	A22 Wi-Fi	HV2	CO2-1	CO2-2
VUT 160 VB EC A14				-	-	-			
VUE 160 VB EC A21				A25	A22	A22 Wi-Fi			
VUE 160 VB EC A14				-	-	-			
VUT 160 V1B EC A21				A25	A22	A22 Wi-Fi			
VUT 160 V1B EC A14				-	-	-			
VUE 160 V1B EC A21				A25	A22	A22 Wi-Fi			
VUE 160 V1B EC A14				-	-	-			
VUT 250 VB EC A21	SF 340x170x48 G4	SF 500x170x48 G4	SF 340x170x48 F7	A25	A22	A22 Wi-Fi	HV2	CO2-1	CO2-2
VUT 250 VBE EC A21				A25	A22	A22 Wi-Fi			
VUT 250 VB EC A14				-	-	-			
VUE 250 VB EC A21				A25	A22	A22 Wi-Fi			
VUE 250 VBE EC A21				A25	A22	A22 Wi-Fi			
VUE 250 VB EC A14				-	-	-			
VUT 350 V1B EC A21	SF 384x196x40 G4		SF 384x196x40 F7	A25	A22	A22 Wi-Fi	HV2	CO2-1	CO2-2
VUT 350 V1B EC A14				-	-	-			
VUT 350 V1B EC A21				A25	A22	A22 Wi-Fi			
VUE 350 V1B EC A14				-	-	-			
VUT 350 VB EC A21	SF 500x196x40 G4		SF 500x196x40 F7	A25	A22	A22 Wi-Fi	HV2	CO2-1	CO2-2
VUT 350 VB EC A14				-	-	-			
VUE 350 VB EC A21				A25	A22	A22 Wi-Fi			
VUE 350 VB EC A14				-	-	-			
VUT 550 VB EC A21	SF 630x198x40 G4		SF 630x198x40 F7	A25	A22	A22 Wi-Fi	HV2	CO2-1	CO2-2
VUT 550 VB EC A14				-	-	-			
VUE 550 VB EC A21				A25	A22	A22 Wi-Fi			
VUE 550 VB EC A14				-	-	-			

Model	Humidity sensor	Electric preheater	Electric reheater	Hydraulic U-trap	Air damper	Electric actuator
VUT 160 VB EC A21	HR-S	NKP-125 A21 V.2	NKD-125 A21 V.2	SH-32	KRV 125	LF230
VUT 160 VB EC A14		-	-			
VUE 160 VB EC A21		NKP-125 A21 V.2	NKD-125 A21 V.2	-		
VUE 160 VB EC A14		-	-			
VUT 160 V1B EC A21		NKP-125 A21 V.2	NKD-125 A21 V.2	SH-32		
VUT 160 V1B EC A14		-	-			
VUE 160 V1B EC A21		NKP-125 A21 V.2	NKD-125 A21 V.2	-		
VUE 160 V1B EC A14		-	-			
VUT 250 VB EC A21		-	NKD-160 A21 V.2			
VUT 250 VBE EC A21		-	NKD-160 A21 V.2	SH-32		
VUT 250 VB EC A14		-	-			
VUE 250 VB EC A21		-	NKD-160 A21 V.2			
VUE 250 VBE EC A21		-	NKD-160 A21 V.2	-		
VUE 250 VB EC A14		-	-			
VUT 350 V1B EC A21		NKP-160 A21 V.2	NKD-160 A21 V.2	SH-32	KRV 160	
VUT 350 V1B EC A14		-	-			
VUE 350 V1B EC A21		NKP-160 A21 V.2	NKD-160 A21 V.2	-		
VUE 350 V1B EC A14		-	-			
VUT 350 VB EC A21		NKP-160 A21 V.2	NKD-160 A21 V.2	SH-32		
VUT 350 VB EC A14		-	-			
VUE 350 VB EC A21		NKP-160 A21 V.2	NKD-160 A21 V.2	-		
VUE 350 VB EC A14		-	-			
VUT 550 VB EC A21		NKP-200 A21 V.2	NKD-200 A21 V.2	SH-32	KRV 200	
VUT 550 VB EC A14		-	-			
VUE 550 VB EC A21	NKP-200 A21 V.2	NKD-200 A21 V.2	-			
VUE 550 VB EC A14	-	-				