

Series
VVG



■ **Applications**

Flexible connectors are designed to exclude the vibration transmission from fans or ventilating units to the air duct as well as for the thermal distortion compensation within the air duct. Applied in ventilation systems with the transferred air temperature over the range of -40 °C to +80 °C.

■ **Design**

Flexible connectors are two flanges made of galvanized sheet steel interconnected by vibration-isolating material made of polyethylene tape reinforced with polyamide fiber. The connectors are not designed for mechanical load and cannot be used as a part of load-bearing construction.

■ **Mounting**

Mounting of flexible connector into the ventilation system is effected by means of end flanges fixing to the mating flanges in the ventilation system. Fixing is performed by means of galvanized bolts and brackets.

Overall dimensions

Type	Dimensions [mm]						Mass [kg]
	B	B1	B2	H	H1	H2	
VVG 400x200	400	420	440	200	220	240	1.1
VVG 500x250	500	520	540	250	270	290	1.4
VVG 500x300	500	520	540	300	320	340	1.6
VVG 600x300	600	620	640	300	320	340	1.82
VVG 600x350	600	620	640	350	370	390	1.95
VVG 700x400	700	720	740	400	420	440	2.4
VVG 800x500	800	820	840	500	520	540	2.8
VVG 900x500	900	920	940	500	520	540	3.0
VVG 1000x500	1000	1020	1040	500	520	540	3.2

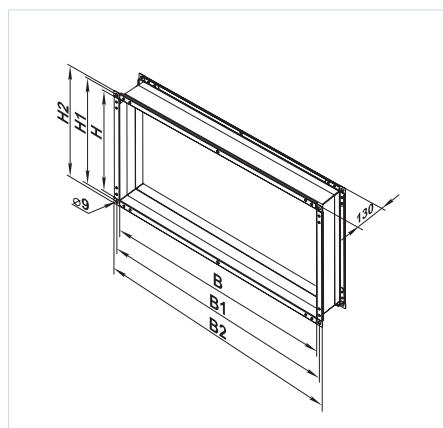

Designation key

Series	Flange dimensions (WxH) [mm]
VVG	400x200; 500x250; 500x300; 600x300; 600x350; 700x400; 800x500; 900x500; 1000x500