

# 100 LD Fresh time turbo

Axial fans for exhaust ventilation with a built-in clock

- Maximum airflow: 115
- Sound pressure level LpA at 3 m: 36
- Motor type: AC
- Casing material: Plastic



	Unit of measurement	100 LD Fresh time turbo
Connected air duct size	mm	100
Speed	-	1
Minimum supply voltage	V	220
Maximum supply voltage	V	240
Power supply frequency	Hz	50
Rated power	W	16
Unit current	A	0.1
Maximum airflow	m <sup>3</sup> /h	115
Sound pressure level LpA at 3 m	dB(A)	36
Weight	kg	0.68
Ambient air temperature min	°C	1
Ambient air temperature max	°C	40
Ingress protection rating	-	IP34

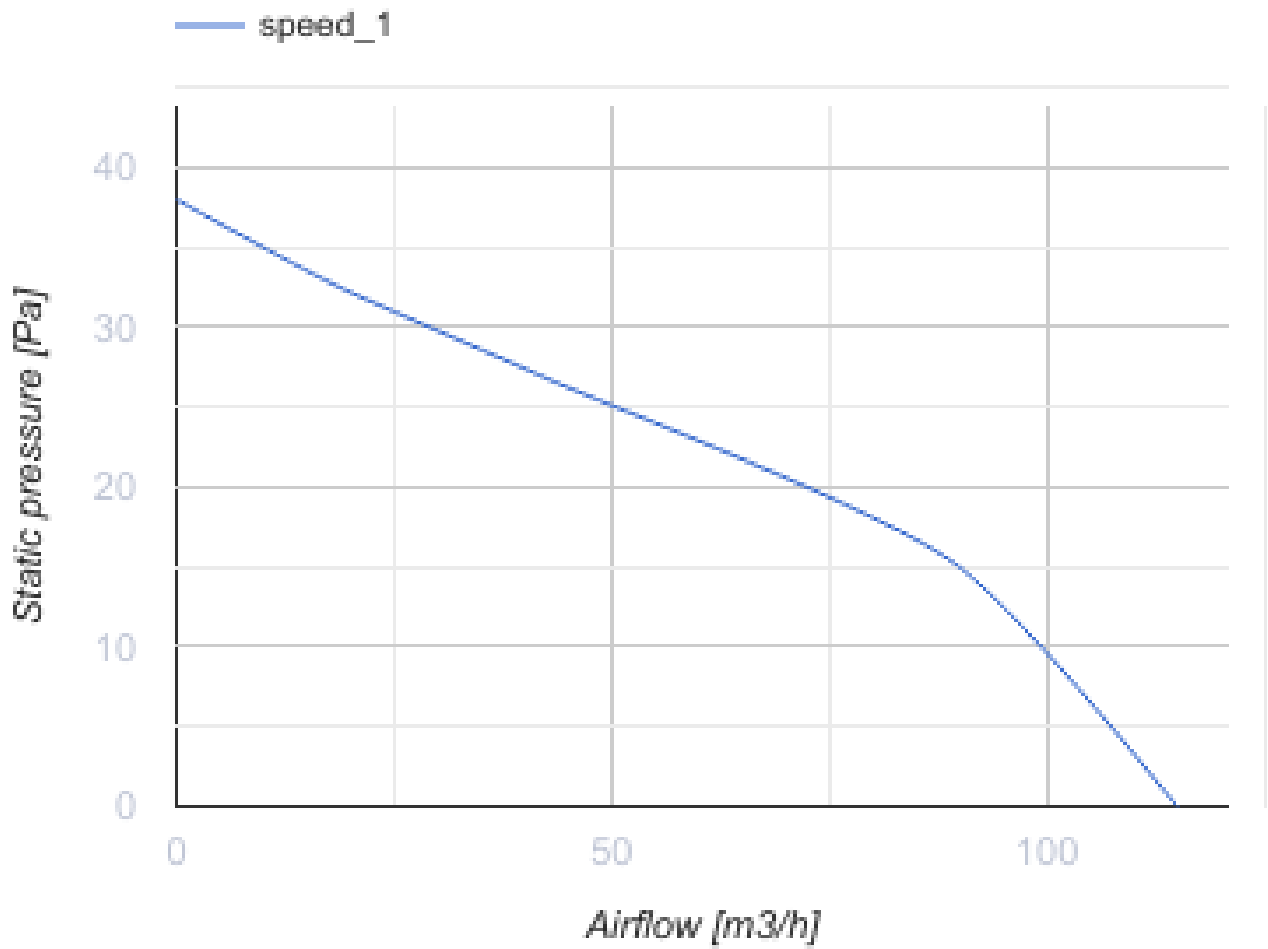

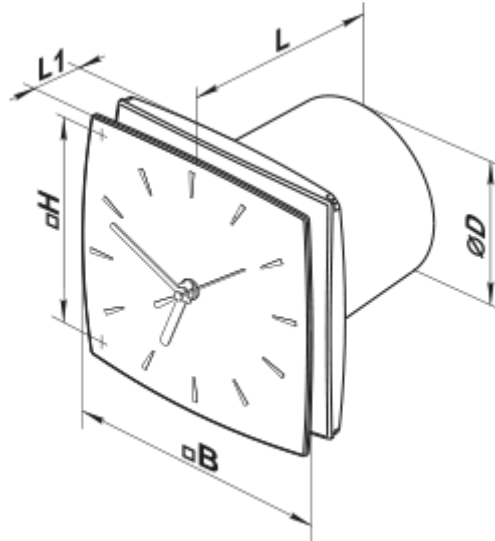

### Dimensions

<b>∅ D</b>	<b>B</b>	<b>H</b>	<b>L</b>	<b>L1</b>
100	152	120	135	40



## Accessories

### Flanges

Name	Photo	Description
<a href="#">KO 100</a>		Back valve is designed for domestic fan series VENTS M, M1, D, S, M3, X, X1, LD, LD Fresh time, Silenta-M, Silenta-S, Modern, Vitro star, Z star, X star
<a href="#">FO 100</a>		The window flange applicable for all VENTS fans except for VKO, VKO1, iFan, Quiet, MAO, CF