

100 LD turbo



Axial decorative fans for exhaust ventilation

- Maximum airflow: 115
- Sound pressure level LpA at 3 m: 36
- Motor type: AC
- Casing material: Plastic

	Unit of measurement	100 LD turbo
Connected air duct size	mm	100
Speed	-	1
Minimum supply voltage	V	220
Maximum supply voltage	V	240
Power supply frequency	Hz	50
Rated power	W	16
Unit current	A	0.1
Maximum airflow	m ³ /h	115
Sound pressure level LpA at 3 m	dB(A)	36
Weight	kg	0.68
Ambient air temperature min	°C	1
Ambient air temperature max	°C	40
Ingress protection rating	-	IP34

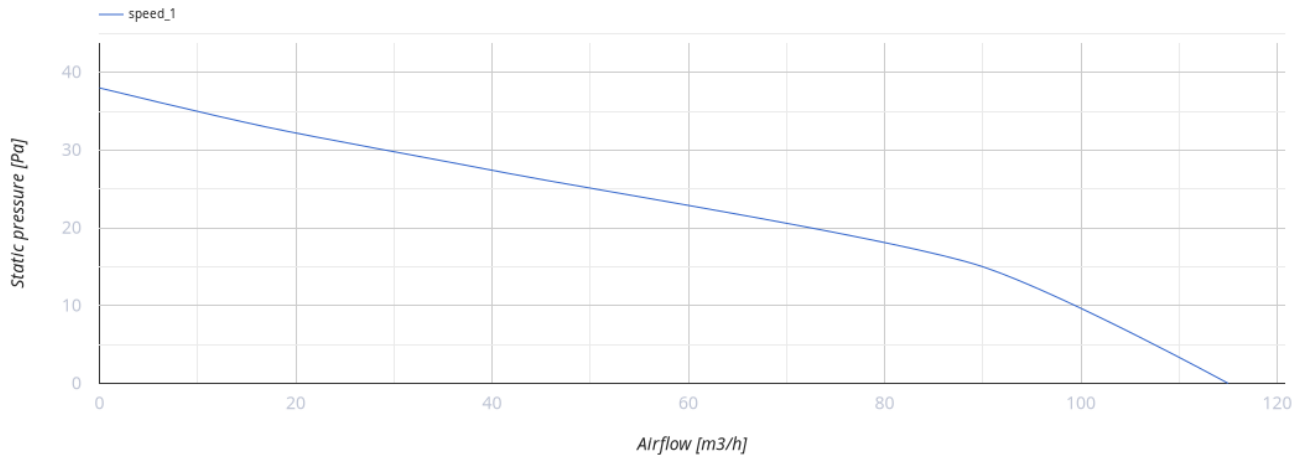

Dimensions

∅D	B	H	L	L1
100	152	120	126	30



Accessories

Flanges

Name	Photo	Description
FO 100		The window flange applicable for all VENTS fans except for VKO, VKO1, iFan, Quiet, MAO, CF
KO 100		Back valve is designed for domestic fan series VENTS M, M1, D, S, M3, X, X1, LD, LD Fresh time, Silenta-M, Silenta-S, Modern, Vitro star, Z star, X star

Ecodesign

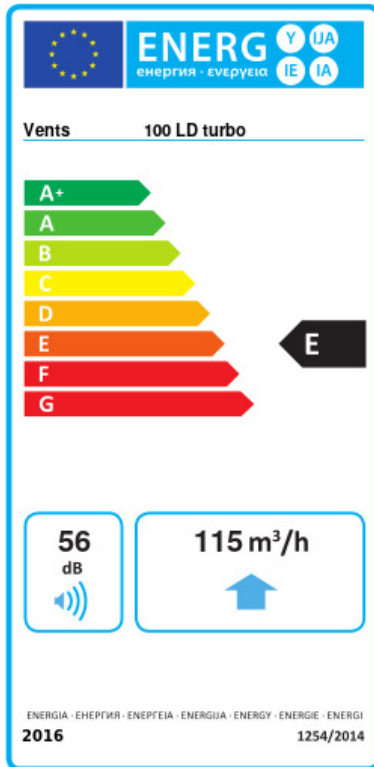

Trademark	Vents					
Model	100 LD turbo					
Specific energy consumption (SEC) (kWh/(m ² /a))	Cold		Average		Warm	
	-29.2	B	-12.8	E	-3.4	F
Type of ventilation unit	Unidirectional					
Type of drive installed	Single speed					
Type of heat recovery system	None					
Maximum flow rate (m ³ /h)	115					
Electric power input (W)	16					
Reference flow rate (m ³ /s)	0.022					
Specific power input (SPI) (W/(m ³ /h))	0.139					
Control typology	Manual control					
Maximum external leakage rates (%)	2.7					
Declared typology	RVU UVU					
Sound power level (dB(A))	56					
The annual electricity consumption (AEC) (kWh/a)	Cold	Average		Warm		
	174	174		174		
The annual heating saved (AHS) (kWh/a)	Cold	Average		Warm		
	3355	1715		776		