

100 M3 V



Axial fans for exhaust ventilation

- Maximum airflow: 98
- Sound pressure level LpA at 3 m: 34
- Motor type: AC
- Casing material: Plastic
- Pull cord

	Unit of measurement	100 M3 V
Connected air duct size	mm	100
Speed	-	1
Minimum supply voltage	V	220
Maximum supply voltage	V	240
Power supply frequency	Hz	50/60
Rated power	W	14
Unit current	A	0.085
Maximum airflow	m ³ /h	98
Sound pressure level LpA at 3 m	dB(A)	34
Weight	kg	0.61
Ambient air temperature min	°C	1
Ambient air temperature max	°C	40
Ingress protection rating	-	IP34

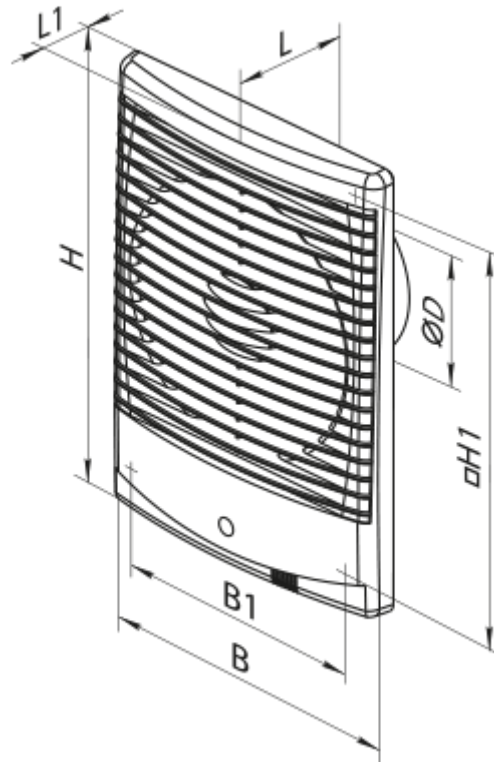

Dimensions

ØD	B	B1	H	H1	L	L1
100	185	155	256	226	86	30



Accessories

Cooker Hoods

Name	Photo	Description
FO 100		The window flange applicable for all VENTS fans except for VKO, VKO1, iFan, Quiet, MAO, CF
KO 100		Back valve is designed for domestic fan series VENTS M, M1, D, S, M3, X, X1, LD, LD Fresh time, Silenta-M, Silenta-S, Modern, Vitro star, Z star, X star