

100 MA L press



Axial fans with automatic louver shutters for exhaust ventilation

- Maximum airflow: 99
- Sound pressure level LpA at 3 m: 37
- Motor type: AC
- Casing material: Polypropylene/Thermoplastic elastomer

	Unit of measurement	100 MA L press
Connected air duct size	mm	100
Speed	-	1
Minimum supply voltage	V	220
Maximum supply voltage	V	240
Power supply frequency	Hz	50/60
Rated power	W	20
Unit current	A	0.1
Maximum airflow	m ³ /h	99
Sound pressure level LpA at 3 m	dB(A)	37
Weight	kg	0.65
Ambient air temperature min	°C	1
Ambient air temperature max	°C	40
Ingress protection rating	-	IP24

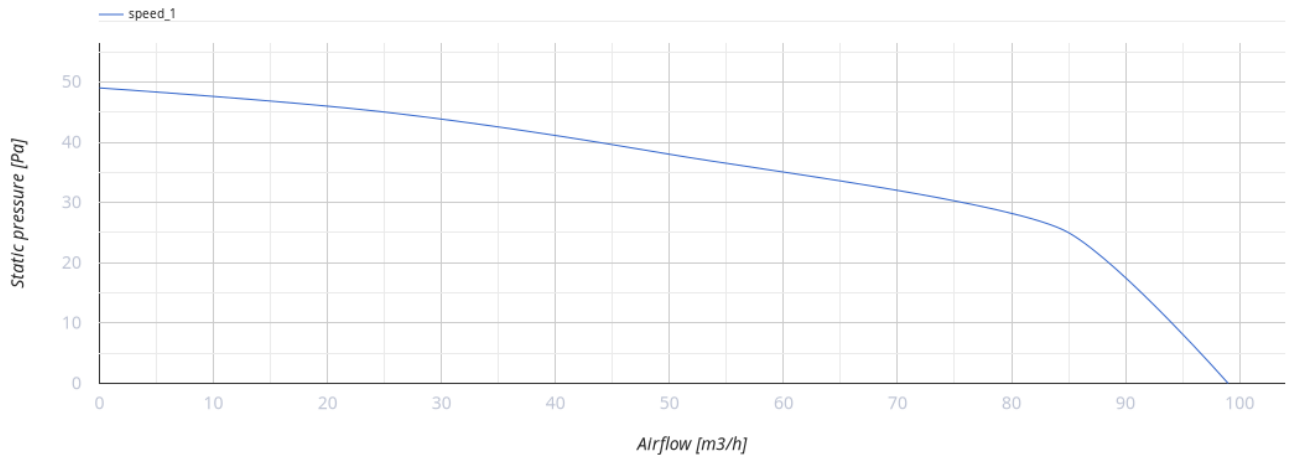

Dimensions

ØD	B	B1	B2	H	L	L1
100	165	150	150	150	92	32

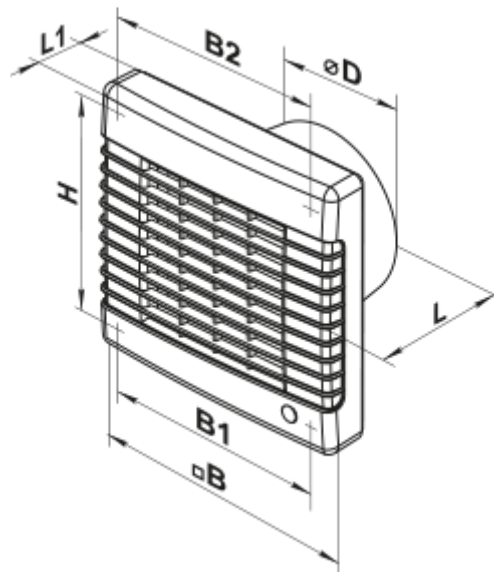

Accessories

Flanges

Name	Photo	Description
FO 100		The window flange applicable for all VENTS fans except for VKO, VKO1, iFan, Quiet, MAO, CF