

100 MF T



Low-noise and energy saving axial fan for exhaust ventilation

- Maximum airflow: 90
- Sound pressure level LpA at 3 m: 29
- Motor type: AC
- Casing material: Plastic
- Backdraft protection: Backdraft damper
- Timer: Turn off timer

	Unit of measurement	100 MF T
Connected air duct size	mm	100
Speed	-	1
Minimum supply voltage	V	220
Maximum supply voltage	V	240
Power supply frequency	Hz	50
Rated power	W	8
Unit current	A	0.05
Maximum airflow	m ³ /h	90
Sound pressure level LpA at 3 m	dB(A)	29
Weight	kg	0.45
Ambient air temperature min	°C	1
Ambient air temperature max	°C	40
Ingress protection rating	-	IP44
ErP compliance	-	2016
Cold - Specific energy consumption (SEC)	kWh/(m ² /a)	34
SEC Class Cold	-	A
Average - Specific energy consumption (SEC)	kWh/(m ² /a)	16.1
SEC Class Average	-	E
Warm - Specific energy consumption (SEC)	kWh/(m ² /a)	5.8
SEC Class Warm	-	F
Unit category	-	RVU

Type of ventilation unit	-	Unidirectional
Type of drive installed	-	Single speed
Type of heat recovery system	-	None
Maximum flow rate	m ³ /h	90
Electric power input	W	8
Reference flow rate	m ³ /s	0.018
Specific power input (SPI)	W/(m ³ /h)	0.089
Control typology	-	Clock control
Maximum external leakage rates	%	2.7
Cold - The annual electricity consumption (AEC)	kWh/a	106
Average - The annual electricity consumption (AEC)	kWh/a	106
Warm - Jährlicher Stromverbrauch (JSV)	kWh/a	106
Cold - The annual heating saved (AHS)	kWh/a	3667
The annual heating saved (AHS) Average	kWh/a	1874
The annual heating saved (AHS) Warm	kWh/a	848
Sound power level	dB(A)	49
Declared typology	-	RVU UVU

Dimensions

ØD	B	L	L1
99	150	79	19

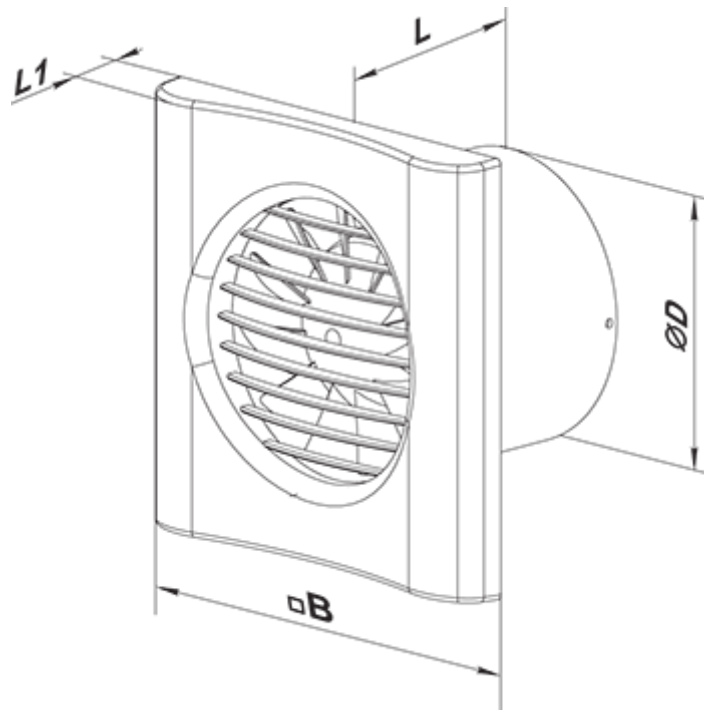

Accessories

Cooker Hoods

Name	Photo	Description
FO 100		The window flange applicable for all VENTS fans except for VKO, VKO1, iFan, Quiet, MAO, CF