

100 MF TH



Low-noise and energy saving axial fan for exhaust ventilation

- Maximum airflow: 90
- Sound pressure level LpA at 3 m: 29
- Motor type: AC
- Casing material: Plastic
- Backdraft protection: Backdraft damper
- Humidity sensor
- Timer: Turn off timer

	Unit of measurement	100 MF TH
Connected air duct size	mm	100
Speed	-	1
Minimum supply voltage	V	220
Maximum supply voltage	V	240
Power supply frequency	Hz	50
Rated power	W	8
Unit current	A	0.05
Maximum airflow	m ³ /h	90
Sound pressure level LpA at 3 m	dB(A)	29
Weight	kg	0.45
Ambient air temperature min	°C	1
Ambient air temperature max	°C	40
Ingress protection rating	-	IP44

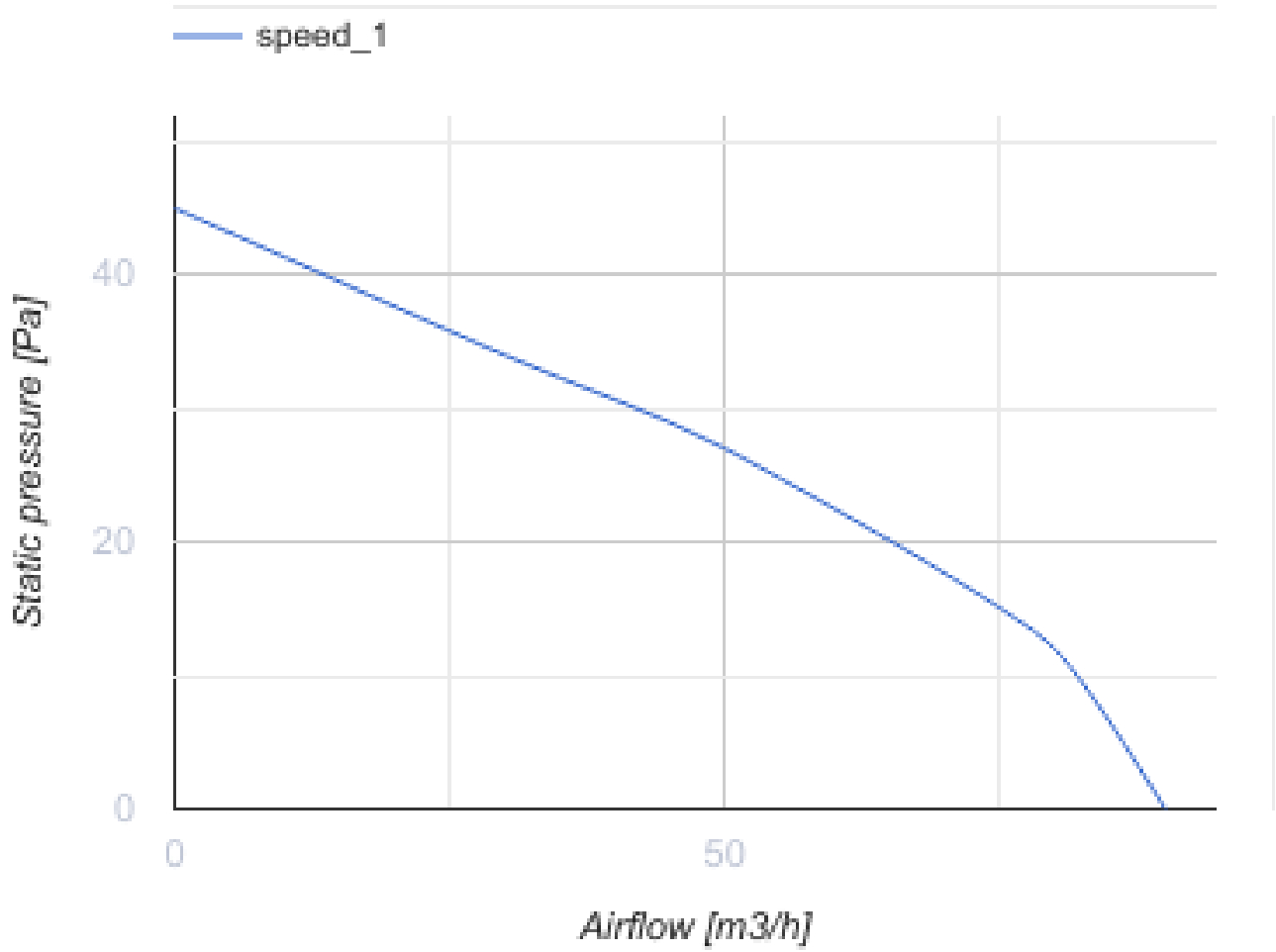

Dimensions

ØD	B	L	L1
99	150	79	19

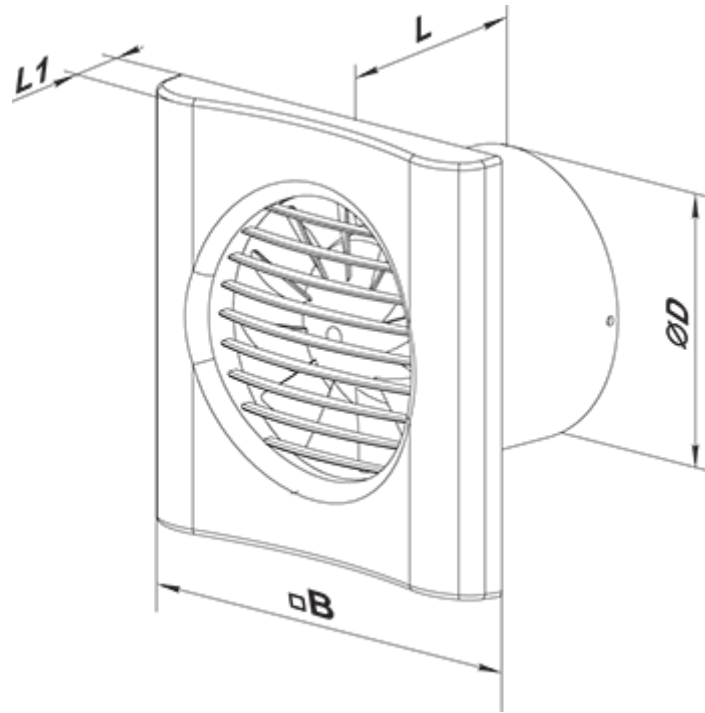

Accessories

Flanges

Name	Photo	Description
FO 100		The window flange applicable for all VENTS fans except for VKO, VKO1, iFan, Quiet, MAO, CF

Ecodesign

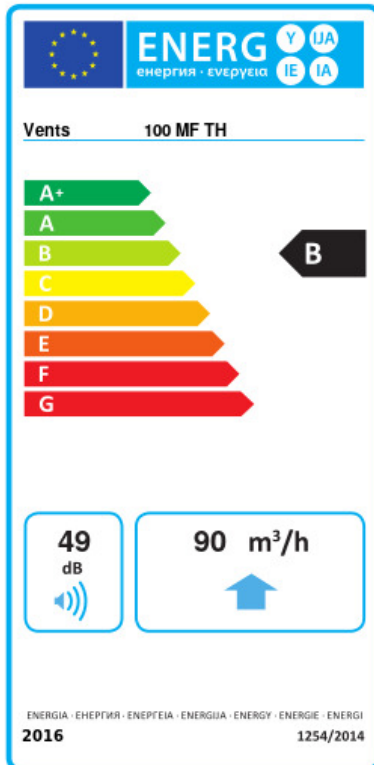

Trademark	Vents					
Model	100 MF TH					
Specific energy consumption (SEC) (kWh/(m ² /a))	Cold		Average		Warm	
	-53.6	A+	-26.5	B	-11	E
Type of ventilation unit	Unidirectional					
Type of drive installed	Single speed					
Type of heat recovery system	None					
Maximum flow rate (m ³ /h)	90					
Electric power input (W)	8					
Reference flow rate (m ³ /s)	0.018					
Specific power input (SPI) (W/(m ³ /h))	0.089					
Control typology	Local demand control					
Maximum external leakage rates (%)	2.7					
Sound power level (dB(A))	49					
Declared typology	RVU UVU					
The annual electricity consumption (AEC) (kWh/a)	Cold		Average		Warm	
	72		72		72	
The annual heating saved (AHS) (kWh/a)	Cold		Average		Warm	
	5536		2830		1280	