

# 100 S 12



Axial fans for exhaust ventilation

- Maximum airflow: 86
- Sound pressure level LpA at 3 m: 33
- Motor type: AC
- Casing material: Polypropylene/Thermoplastic elastomer

	Unit of measurement	100 S 12
Connected air duct size	mm	100
Speed	-	1
Minimum supply voltage	V	12
Maximum supply voltage	V	12
Power supply frequency	Hz	50/60
Rated power	W	14
Unit current	A	1.5
Maximum airflow	m <sup>3</sup> /h	86
Sound pressure level LpA at 3 m	dB(A)	33
Weight	kg	0.6
Ambient air temperature min	°C	1
Ambient air temperature max	°C	40
Ingress protection rating	-	IP34

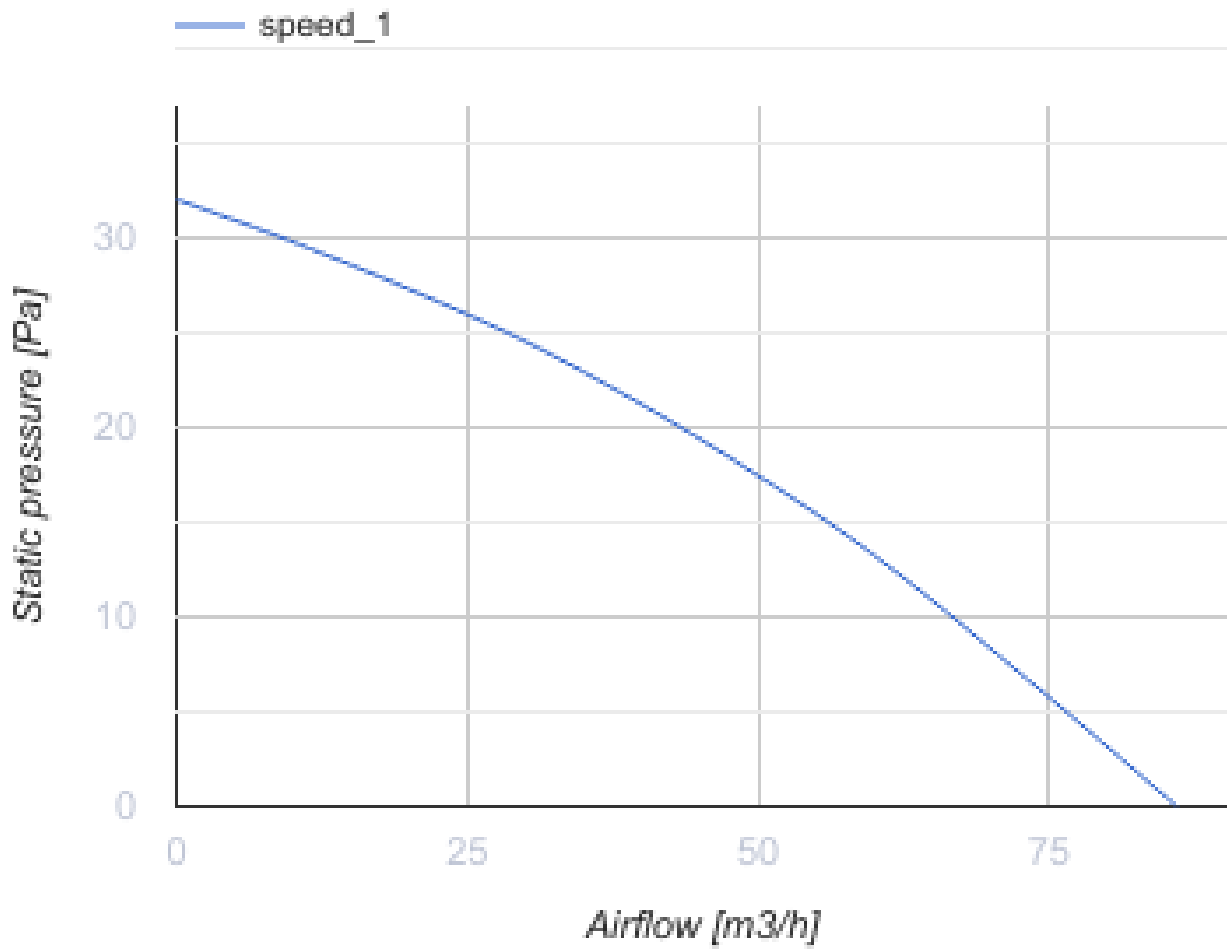

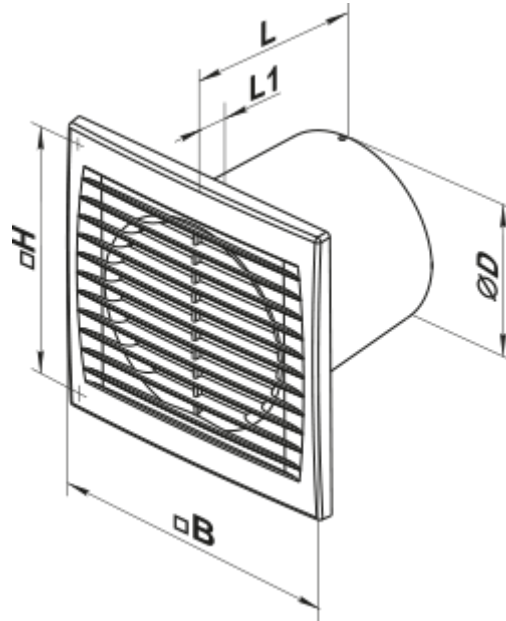

### Dimensions

<b>Ø D</b>	<b>B</b>	<b>H</b>	<b>L</b>	<b>L1</b>
100	150	120	108	12



## Accessories

### Flanges

Name	Photo	Description
<a href="#">FO_100</a>		The window flange applicable for all VENTS fans except for VKO, VKO1, iFan, Quiet, MAO, CF
<a href="#">KO_100</a>		Back valve is designed for domestic fan series VENTS M, M1, D, S, M3, X, X1, LD, LD Fresh time, Silenta-M, Silenta-S, Modern, Vitro star, Z star, X star

## Ecodesign

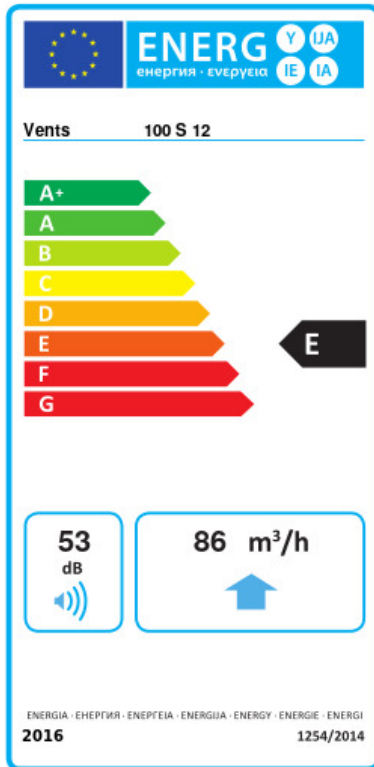

Trademark	Vents					
Model	100 S 12					
Specific energy consumption (SEC) (kWh/(m <sup>2</sup> /a))	Cold		Average		Warm	
	-28.5	B	-12.1	E	-2.7	F
Type of ventilation unit	Unidirectional					
Type of drive installed	Single speed					
Type of heat recovery system	None					
Maximum flow rate (m <sup>3</sup> /h)	86					
Electric power input (W)	14					
Reference flow rate (m <sup>3</sup> /s)	0.017					
Specific power input (SPI) (W/(m <sup>3</sup> /h))	0.163					
Control typology	Manual control					
Maximum external leakage rates (%)	2.7					
Declared typology	RVU UVU					
Sound power level (dB(A))	53					
The annual electricity consumption (AEC) (kWh/a)	Cold		Average		Warm	
	204		204		204	
The annual heating saved (AHS) (kWh/a)	Cold		Average		Warm	
	3355		1715		776	