

# 100 S T



Axial fans for exhaust ventilation

- Maximum airflow: 95
- Sound pressure level LpA at 3 m: 34
- Motor type: AC
- Casing material: Polypropylene/Thermoplastic elastomer
- Timer: Turn off timer

	Unit of measurement	100 S T
Connected air duct size	mm	100
Speed	-	1
Minimum supply voltage	V	220
Maximum supply voltage	V	240
Power supply frequency	Hz	50
Rated power	W	14
Unit current	A	0.085
Maximum airflow	m <sup>3</sup> /h	95
Sound pressure level LpA at 3 m	dB(A)	34
Weight	kg	0.58
Ambient air temperature min	°C	1
Ambient air temperature max	°C	40
Ingress protection rating	-	IP34

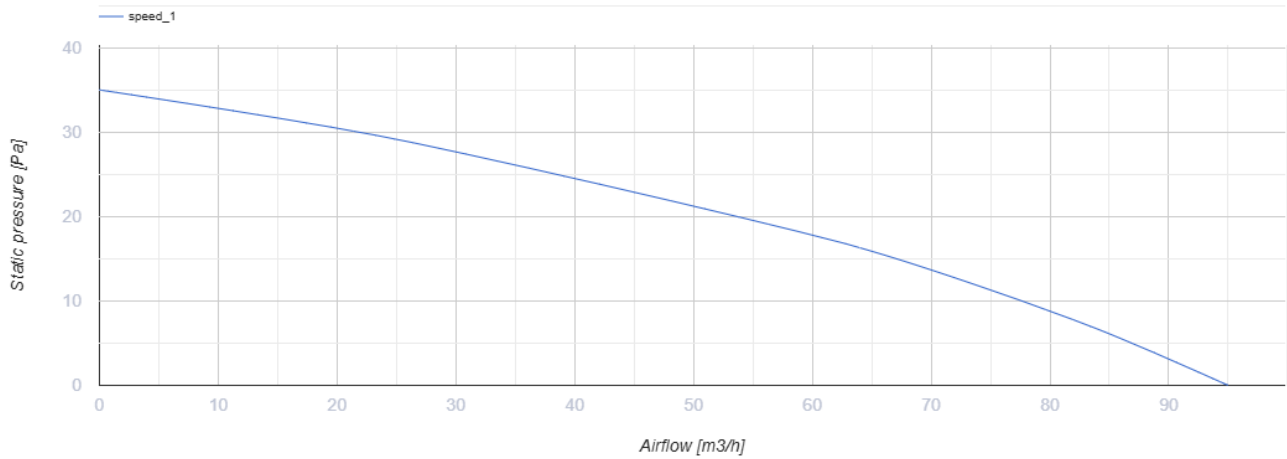

## Dimensions

Ø D	B	H	L	L1
100	150	120	108	12

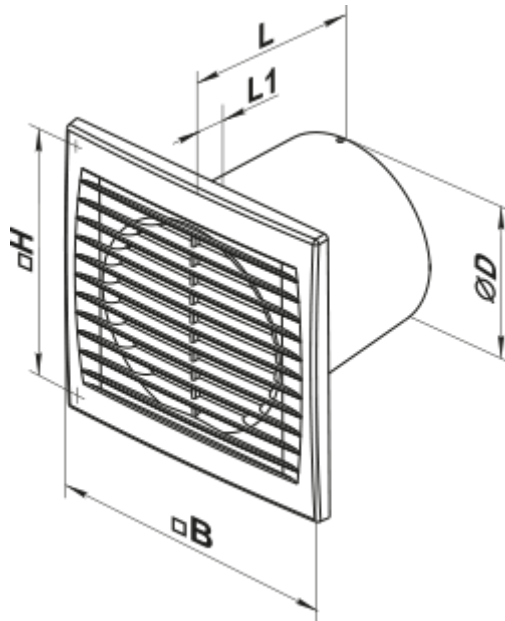

## Accessories

### Flanges

Name	Photo	Description
<a href="#">FO 100</a>		The window flange applicable for all VENTS fans except for VKO, VKO1, iFan, Quiet, MAO, CF

[KO\\_100](#)



Back valve is designed for domestic fan series VENTS M, M1, D, S, M3, X, X1, LD, LD  
Fresh time, Silenta-M, Silenta-S, Modern, Vitro star, Z star, X star

## Ecodesign

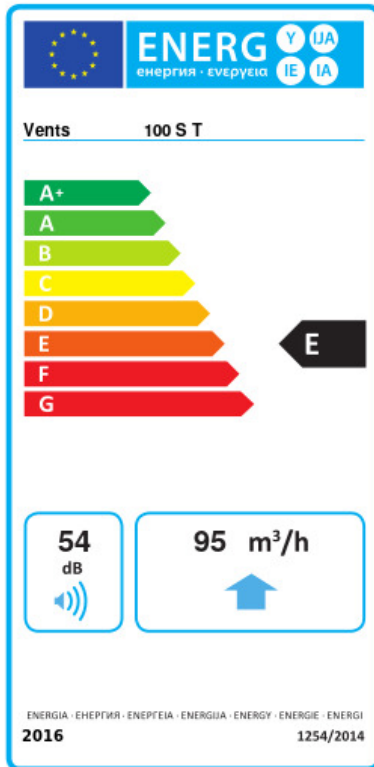

Trademark	Vents					
Model	100 S T					
Specific energy consumption (SEC) (kWh/(m <sup>2</sup> /a))	Cold		Average		Warm	
	-32.3	B	-14.4	E	-4.1	F
Type of ventilation unit	Unidirectional					
Type of drive installed	Single speed					
Type of heat recovery system	None					
Maximum flow rate (m <sup>3</sup> /h)	95					
Electric power input (W)	14					
Reference flow rate (m <sup>3</sup> /s)	0.018					
Specific power input (SPI) (W/(m <sup>3</sup> /h))	0.147					
Control typology	Clock control					
Maximum external leakage rates (%)	2.7					
Declared typology	RVU UVU					
Sound power level (dB(A))	54					
The annual electricity consumption (AEC) (kWh/a)	Cold		Average		Warm	
	175		175		175	
The annual heating saved (AHS) (kWh/a)	Cold		Average		Warm	
	3667		1874		848	