

100 Solid T Black Sapphire



Low-noise and low-power extract axial fan with air flow up to 155 m³/h

- Maximum airflow: 85
- Sound pressure level LpA at 3 m: 27
- Motor type: AC
- Casing material: Polypropylene/Thermoplastic elastomer
- Backdraft protection: Backdraft damper
- Timer: Turn off timer

	Unit of measurement	100 Solid T Black Sapphire
Connected air duct size	mm	100
Speed	-	1
Minimum supply voltage	V	220
Maximum supply voltage	V	240
Power supply frequency	Hz	50
Rated power	W	8
Unit current	A	0.05
Maximum airflow	m ³ /h	85
Sound pressure level LpA at 3 m	dB(A)	27
Weight	kg	0.51
Ambient air temperature min	°C	1
Ambient air temperature max	°C	45
Ingress protection rating	-	IP44

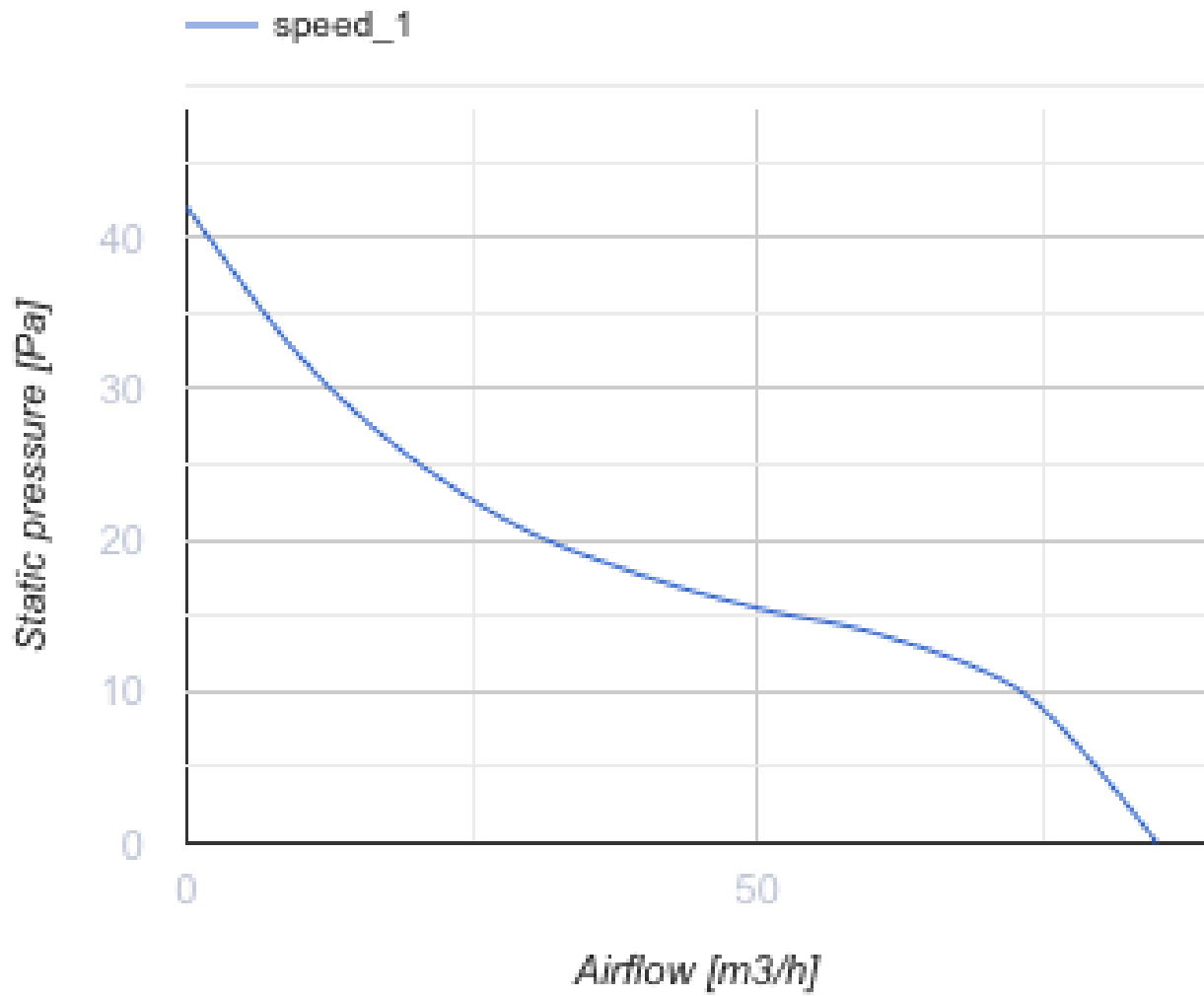

Dimensions

Ø D	B	L	L1
99	160	79	38



Accessories

Flanges

Name	Photo	Description
FO 100		The window flange applicable for all VENTS fans except for VKO, VKO1, iFan, Quiet, MAO, CF