

100 VKO1 turbo



Axial inline fans, for exhaust or supply ventilation

- Maximum airflow: 137
- Sound pressure level LpA at 3 m: 37
- Motor type: AC
- Casing material: Plastic

	Unit of measurement	100 VKO1 turbo
Connected air duct size	mm	100
Speed	-	1
Minimum supply voltage	V	220
Maximum supply voltage	V	240
Power supply frequency	Hz	50/60
Rated power	W	16
Unit current	A	0.1
Maximum airflow	m ³ /h	137
Sound pressure level LpA at 3 m	dB(A)	37
Weight	kg	0.49
Ambient air temperature min	°C	1
Ambient air temperature max	°C	40
Ingress protection rating	-	IPX4

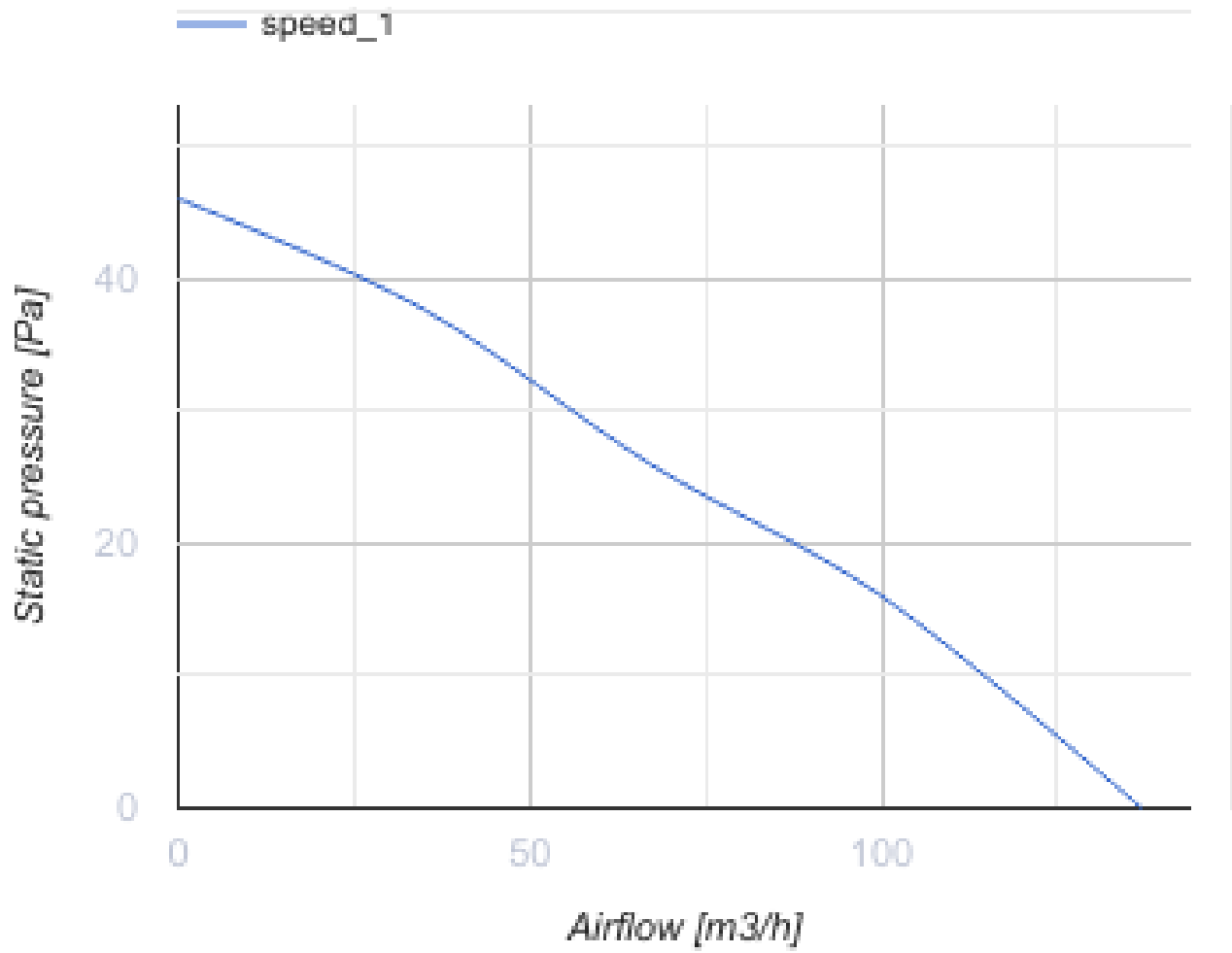

Dimensions

$\varnothing D$	$\varnothing d$	L	L1
100	59	100	10

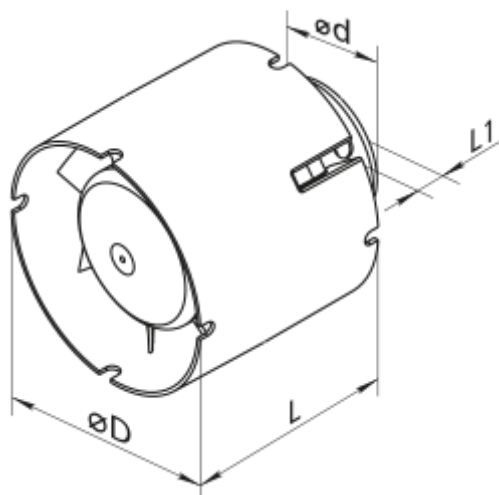

Ecodesign

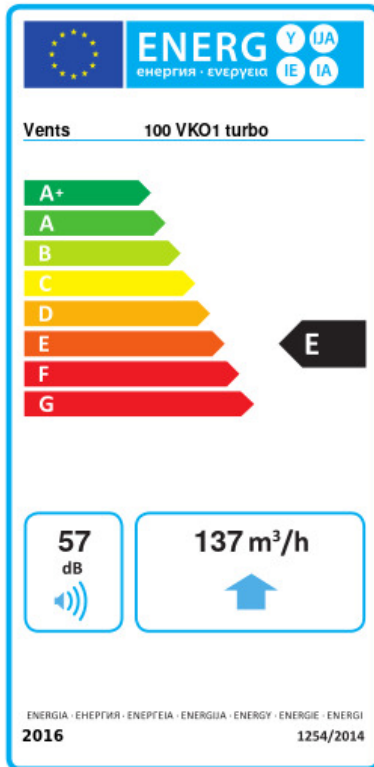

Trademark	Vents					
Model	100 VKO1 turbo					
Specific energy consumption (SEC) (kWh/(m ² /a))	Cold		Average		Warm	
	-31	B	-15	E	-5	F
Type of ventilation unit	Unidirectional					
Type of drive installed	Multi-speed					
Type of heat recovery system	None					
Maximum flow rate (m ³ /h)	137					
Electric power input (W)	16					
Reference flow rate (m ³ /s)	0.027					
Specific power input (SPI) (W/(m ³ /h))	0.075					
Control typology	Manual control					
Maximum external leakage rates (%)	2.7					
Declared typology	RVU UVU					
Sound power level (dB(A))	57					
The annual electricity consumption (AEC) (kWh/a)	Cold		Average		Warm	
	100		100		100	
The annual heating saved (AHS) (kWh/a)	Cold		Average		Warm	
	3400		1700		800	