

100 Wave



Axial decorative fans for extract ventilation with low power consumption

- Maximum airflow: 85
- Sound pressure level LpA at 3 m: 27
- Motor type: AC
- Casing material: Plastic
- Backdraft protection: Backdraft damper

	Unit of measurement	100 Wave
Connected air duct size	mm	100
Speed	-	1
Minimum supply voltage	V	220
Maximum supply voltage	V	240
Power supply frequency	Hz	50
Rated power	W	8
Unit current	A	0.05
Maximum airflow	m ³ /h	85
Sound pressure level LpA at 3 m	dB(A)	27
Weight	kg	0.51
Ambient air temperature min	°C	1
Ambient air temperature max	°C	45
Ingress protection rating	-	IP44

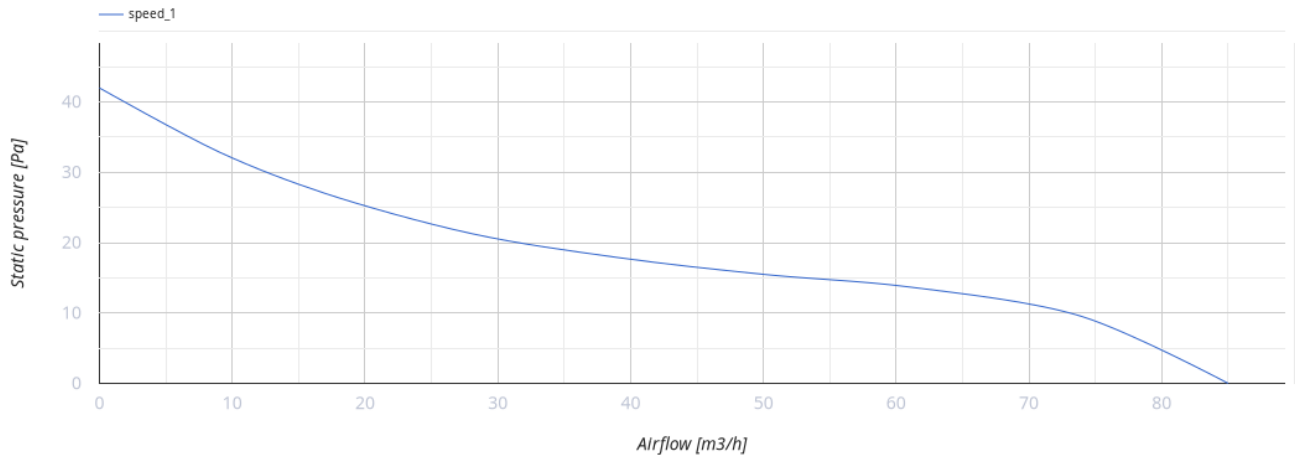

Dimensions

ØD	B	L	L1
99	160	79	38

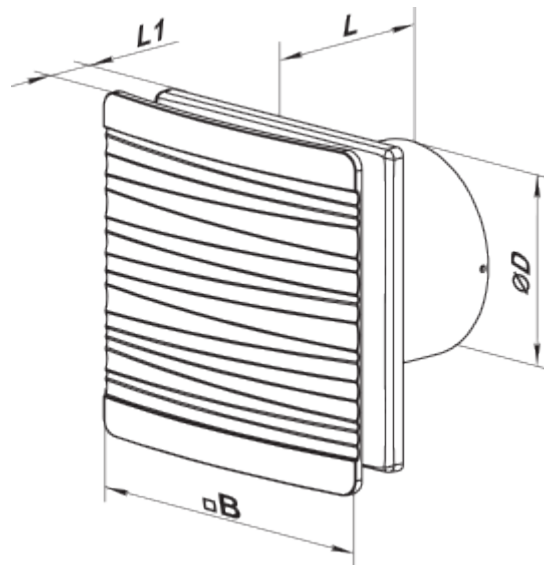

Accessories

Flanges

Name	Photo	Description
FO_100		The window flange applicable for all VENTS fans except for VKO, VKO1, iFan, Quiet, MAO, CF

Ecodesign

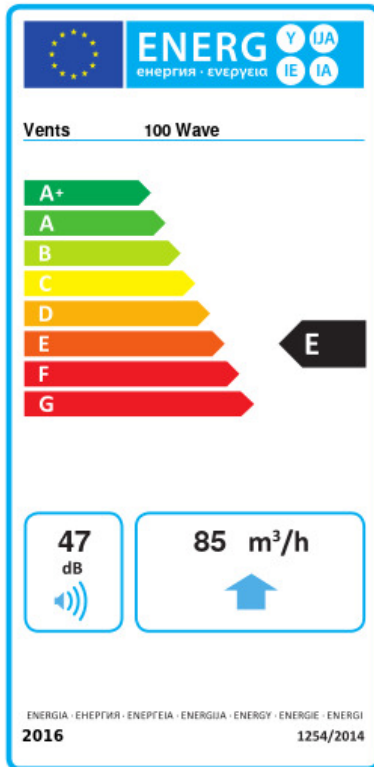

Trademark	Vents					
Model	100 Wave					
Specific energy consumption (SEC) (kWh/(m ² /a))	Cold		Average		Warm	
	-30.6	B	-14.2	E	-4.8	F
Type of ventilation unit	Unidirectional					
Type of drive installed	Single speed					
Type of heat recovery system	None					
Maximum flow rate (m ³ /h)	85					
Electric power input (W)	8					
Reference flow rate (m ³ /s)	0.017					
Specific power input (SPI) (W/(m ³ /h))	0.094					
Control typology	Manual control					
Maximum external leakage rates (%)	2.7					
Declared typology	RVU UVU					
Sound power level (dB(A))	47					
The annual electricity consumption (AEC) (kWh/a)	Cold		Average		Warm	
	118		118		118	
The annual heating saved (AHS) (kWh/a)	Cold		Average		Warm	
	3355		1715		776	