

125 LD VTH



Axial decorative fans for extract ventilation with panels

- Maximum airflow: 167
- Sound pressure level LpA at 3 m: 34
- Motor type: AC
- Casing material: Plastic
- Pull cord
- Humidity sensor
- Timer: Turn off timer

	Unit of measurement	125 LD VTH
Connected air duct size	mm	125
Speed	-	1
Minimum supply voltage	V	220
Maximum supply voltage	V	240
Power supply frequency	Hz	50
Rated power	W	16
Unit current	A	0.1
Maximum airflow	m ³ /h	167
Sound pressure level LpA at 3 m	dB(A)	34
Weight	kg	0.74
Ambient air temperature min	°C	1
Ambient air temperature max	°C	40
Ingress protection rating	-	IP34





Dimensions

$\varnothing D$	B	H	L	L1
125	177	140	135	34



Accessories

Flanges

Name	Photo	Description
FO_125		The window flange applicable for all VENTS fans except for VKO, VKO1, iFan, Quiet, MAO, CF
KO_125		Back valve is designed for domestic fan series VENTS M, M1, D, S, M3, X, X1, LD, LD Fresh time, Silenta-M, Silenta-S, Modern, Vitro star, Z star, X star

Ecodesign

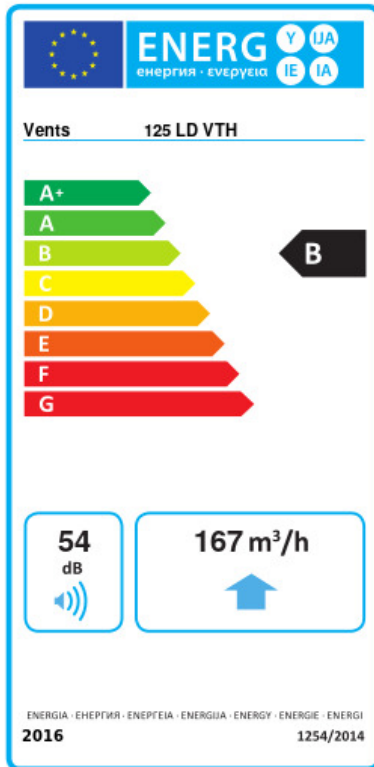

Trademark	Vents					
Model	125 LD VTH					
Specific energy consumption (SEC) (kWh/(m ² /a))	Cold		Average		Warm	
	-53.4	A+	-26.3	B	-10.8	E
Type of ventilation unit	Unidirectional					
Type of drive installed	Single speed					
Type of heat recovery system	None					
Maximum flow rate (m ³ /h)	167					
Electric power input (W)	16					
Reference flow rate (m ³ /s)	0.032					
Specific power input (SPI) (W/(m ³ /h))	0.096					
Control typology	Local demand control					
Maximum external leakage rates (%)	2.7					
Sound power level (dB(A))	54					
Declared typology	RVU UVU					
The annual electricity consumption (AEC) (kWh/a)	Cold		Average		Warm	
	78		78		78	
The annual heating saved (AHS) (kWh/a)	Cold		Average		Warm	
	5536		2830		1280	