

150 K L



Axial fans for exhaust ventilation with the capacity up to 341 m³/h. Compatible with 100, 125 or 150 mm air ducts.

- Maximum airflow: 292
- Sound pressure level LpA at 3 m: 38
- Motor type: AC
- Casing material: Plastic

	Unit of measurement	150 K L
Connected air duct size	mm	150
Speed	-	1
Minimum supply voltage	V	220
Maximum supply voltage	V	240
Power supply frequency	Hz	50
Rated power	W	24
Unit current	A	0.13
Maximum airflow	m ³ /h	292
Sound pressure level LpA at 3 m	dB(A)	38
Weight	kg	1.07
Ambient air temperature min	°C	1
Ambient air temperature max	°C	40
Ingress protection rating	-	IP34

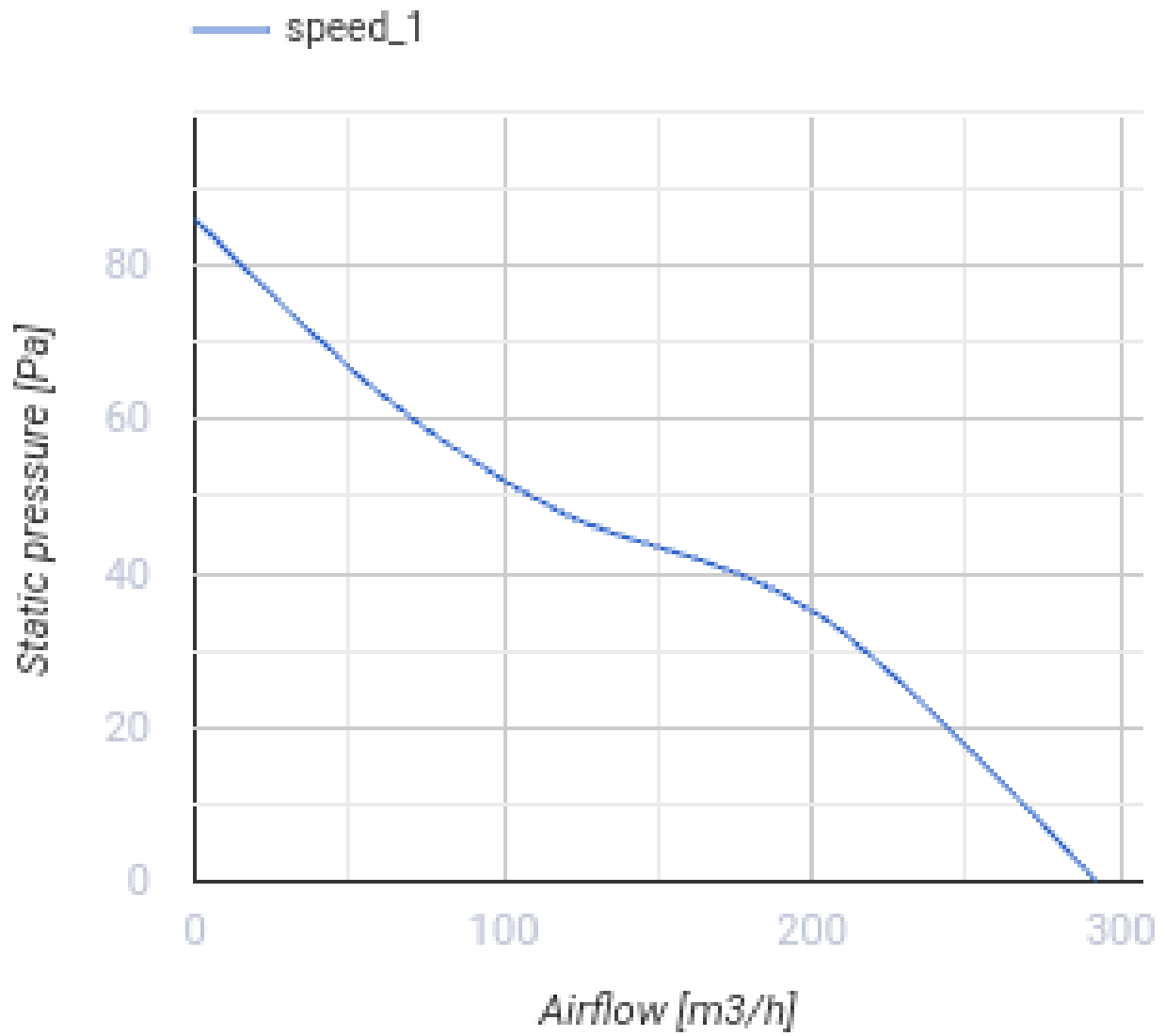

Dimensions

ØD	B	H	L	L1
150	250	214	127	15

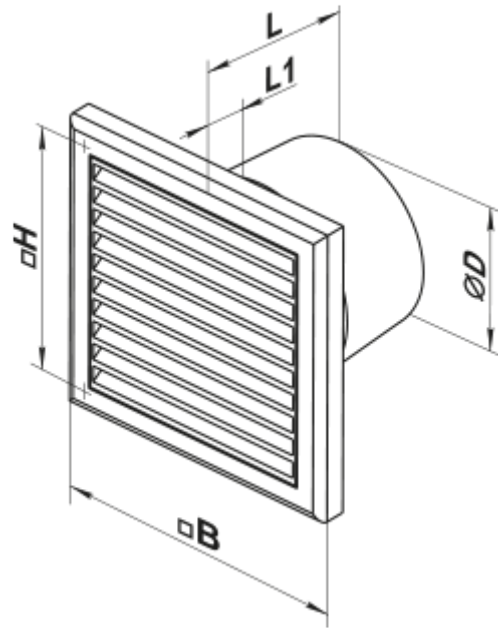

Accessories

Flanges

Name	Photo	Description
FO_150		The window flange applicable for all VENTS fans except for VKO, VKO1, iFan, Quiet, MAO, CF