

150 M3 turbo



Axial fans for exhaust ventilation

- Maximum airflow: 345
- Sound pressure level LpA at 3 m: 43
- Motor type: AC
- Casing material: Plastic

	Unit of measurement	150 M3 turbo
Connected air duct size	mm	150
Speed	-	1
Minimum supply voltage	V	220
Maximum supply voltage	V	240
Power supply frequency	Hz	50
Rated power	W	29
Unit current	A	0.13
Maximum airflow	m ³ /h	345
Sound pressure level LpA at 3 m	dB(A)	43
Weight	kg	1.01
Ambient air temperature min	°C	1
Ambient air temperature max	°C	40
Ingress protection rating	-	IP34



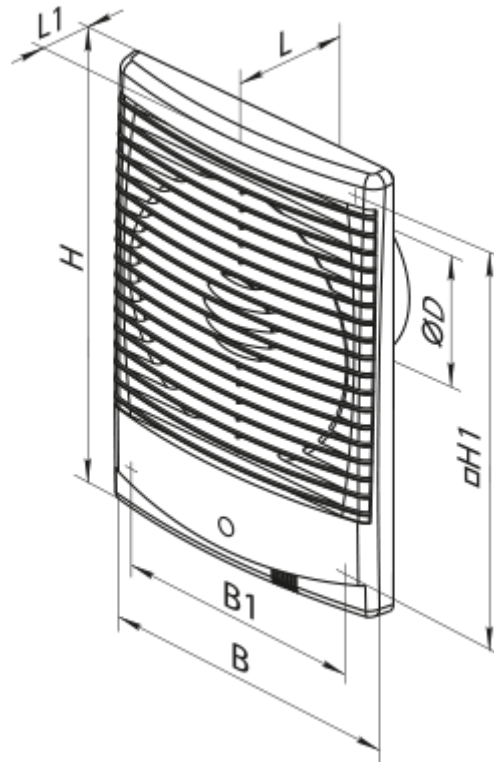

Dimensions

∅D	B	B1	H	H1	L	L1
150	185	155	256	226	114	30



Accessories

Flanges

Name	Photo	Description
FO 150		The window flange applicable for all VENTS fans except for VKO, VKO1, iFan, Quiet, MAO, CF
KO 150		Back valve is designed for domestic fan series VENTS M, M1, D, S, M3, X, X1, LD, LD Fresh time, Silenta-M, Silenta-S, Modern, Vitro star, Z star, X star

Ecodesign

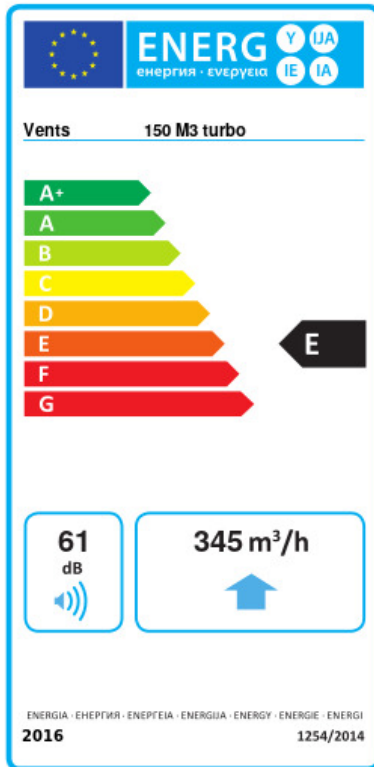

Trademark	Vents					
Model	150 M3 turbo					
Specific energy consumption (SEC) (kWh/(m ² /a))	Cold		Average		Warm	
	-32	B	-15	E	-6	F
Type of ventilation unit	Unidirectional					
Type of drive installed	Multi-speed					
Type of heat recovery system	None					
Maximum flow rate (m ³ /h)	345					
Electric power input (W)	29					
Reference flow rate (m ³ /s)	0.067					
Specific power input (SPI) (W/(m ³ /h))	0.054					
Control typology	Manual control					
Maximum external leakage rates (%)	2.7					
Declared typology	RVU UVU					
Sound power level (dB(A))	61					
The annual electricity consumption (AEC) (kWh/a)	Cold		Average		Warm	
	100		100		100	
The annual heating saved (AHS) (kWh/a)	Cold		Average		Warm	
	3400		1700		800	