

150 VK01 12



Axial high-performance inline fans for extract or supply ventilation with high performance

- Maximum airflow: 272
- Sound pressure level LpA at 3 m: 39
- Motor type: AC
- Casing material: Polypropylene/Thermoplastic elastomer

	Unit of measurement	150 VK01 12
Connected air duct size	mm	150
Speed	-	1
Minimum supply voltage	V	12
Maximum supply voltage	V	12
Power supply frequency	Hz	50
Rated power	W	24
Unit current	A	2
Maximum airflow	m ³ /h	272
Sound pressure level LpA at 3 m	dB(A)	39
Weight	kg	0.76
Ambient air temperature min	°C	1
Ambient air temperature max	°C	40
Ingress protection rating	-	IPX4

Dimensions

ØD	Ød	L	L1
150	59	100	28



Ecodesign

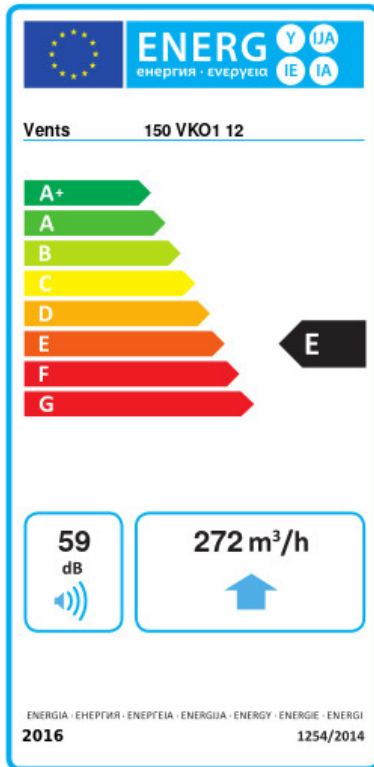

Trademark	Vents					
Model	150 VKO1 12					
Specific energy consumption (SEC) (kWh/(m ² /a))	Cold		Average		Warm	
	-32	B	-15	E	-6	F
Type of ventilation unit	Unidirectional					
Type of drive installed	Multi-speed					
Type of heat recovery system	None					
Maximum flow rate (m ³ /h)	272					
Electric power input (W)	24					
Reference flow rate (m ³ /s)	0.053					
Specific power input (SPI) (W/(m ³ /h))	0.057					
Control typology	Manual control					
Maximum external leakage rates (%)	2.7					
Declared typology	RVU UVU					
Sound power level (dB(A))	59					
The annual electricity consumption (AEC) (kWh/a)	Cold		Average		Warm	
	100		100		100	
The annual heating saved (AHS) (kWh/a)	Cold		Average		Warm	
	3400		1700		800	