

Alta 100 TR



Fans with automatic shutters for exhaust ventilation

- Maximum airflow: 90
- Sound pressure level LpA at 3 m: 25
- Motor type: AC
- Impeller type: Mixed
- Casing material: ABS Plastic
- Backdraft protection: Automatic shutters
- Motion sensor
- Timer: Turn off timer

| | Unit of measurement | Alta 100 TR |
|-----------------------------------|---------------------|-------------|
| Connected air duct size | mm | 100 |
| Speed | - | 1 |
| Minimum supply voltage | V | 220 |
| Maximum supply voltage | V | 240 |
| Power supply frequency | Hz | 50 |
| Rated power | W | 11 |
| Unit current | A | 0.056 |
| Maximum airflow | m ³ /h | 90 |
| Sound pressure level LpA at 3 m | dB(A) | 25 |
| Weight | kg | 0.63 |
| Transported air temperature (max) | °C | 40 |
| Transported air temperature (min) | °C | 1 |
| Ingress protection rating | - | IP24 |

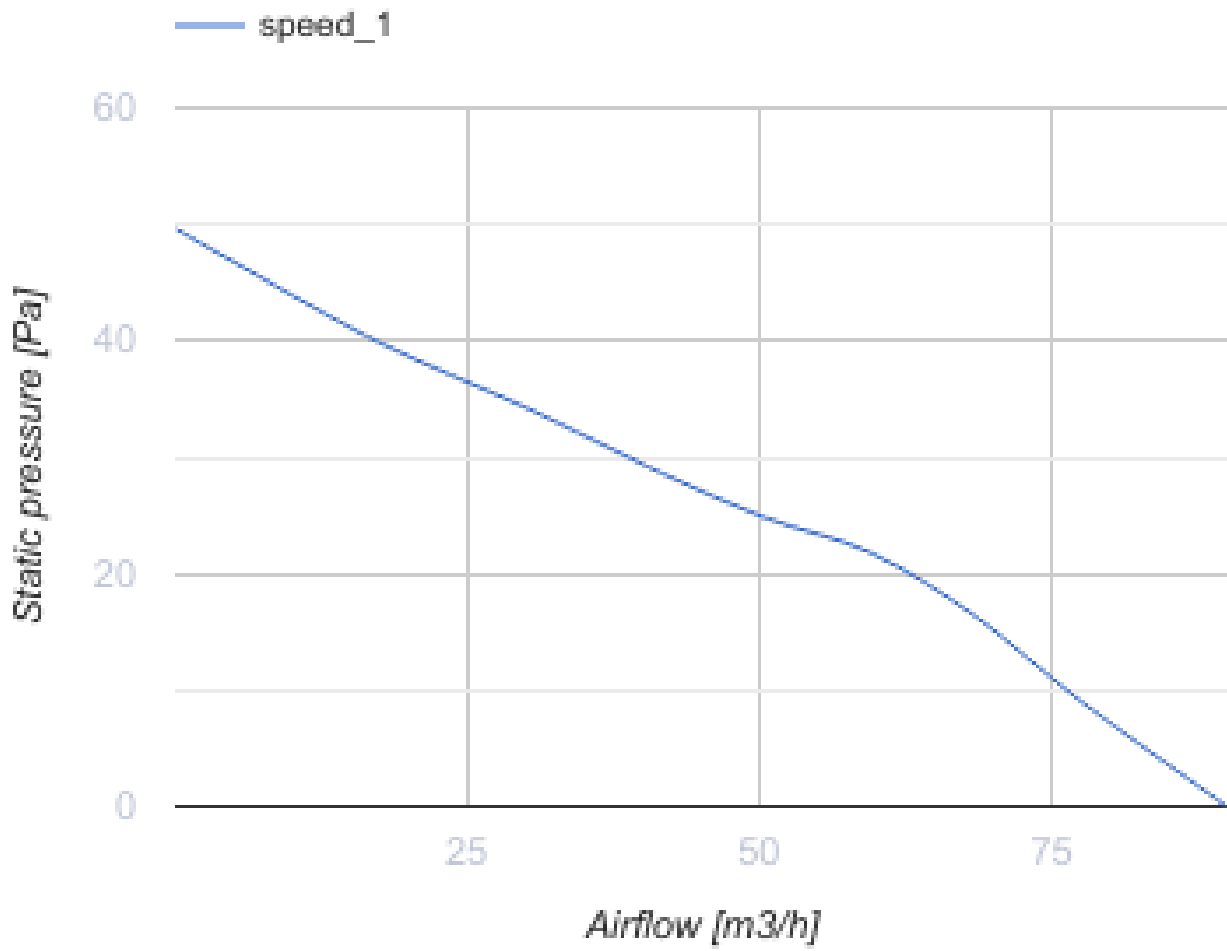

Dimensions

| D | B | L | L1 |
|----|-----|-----|----|
| 99 | 168 | 110 | 29 |

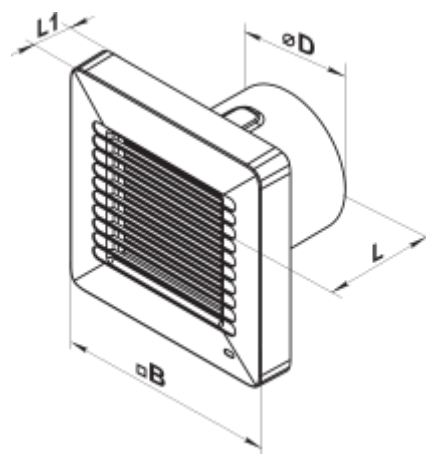

Accessories

Flanges

| Name | Photo | Description |
|------------------------|---|--|
| FO 100 |  | The window flange applicable for all VENTS fans except for VKO, VKO1, iFan, Quiet, MAO, CF |

Ecodesign



| | | | | | | |
|---|----------------|---|---------|---|------|---|
| Trademark | Vents | | | | | |
| Model | Alta 100 TR | | | | | |
| Specific energy consumption (SEC) (kWh/(m ² /a)) | Cold | | Average | | Warm | |
| | 0 | B | 0 | E | 0 | F |
| Type of ventilation unit | Unidirectional | | | | | |
| Type of drive installed | Single speed | | | | | |
| Type of heat recovery system | None | | | | | |
| Maximum flow rate (m ³ /h) | 0 | | | | | |
| Electric power input (W) | 0 | | | | | |
| Reference flow rate (m ³ /s) | 0 | | | | | |
| Specific power input (SPI) (W/(m ³ /h)) | 0 | | | | | |
| Control typology | Manual control | | | | | |
| Maximum external leakage rates (%) | 0 | | | | | |
| Sound power level (dB(A)) | 0 | | | | | |
| Declared typology | RVU UVU | | | | | |
| The annual electricity consumption (AEC) (kWh/a) | Cold | | Average | | Warm | |
| | 0 | | 0 | | 0 | |
| The annual heating saved (AHS) (kWh/a) | Cold | | Average | | Warm | |
| | 0 | | 0 | | 0 | |