

# Alta 100 VTH L



Quiet axial extract fans with automatic shutters

- Maximum airflow: 90
- Sound pressure level LpA at 3 m: 25
- Motor type: AC
- Impeller type: Mixed-flow
- Casing material: ABS Plastic
- Backdraft protection: Automatic shutters
- Pull cord
- Humidity sensor
- Timer: Turn off timer

	Unit of measurement	Alta 100 VTH L
Connected air duct size	mm	100
Speed	-	1
Minimum supply voltage	V	220
Maximum supply voltage	V	240
Power supply frequency	Hz	50
Rated power	W	11
Unit current	A	0.056
Maximum airflow	m <sup>3</sup> /h	90
rotation speed at 50hz	-	2300
Sound pressure level LpA at 3 m	dB(A)	25
Weight	kg	0.63
Transported air temperature (max)	°C	40
Transported air temperature (min)	°C	1
Ingress protection rating	-	IP24

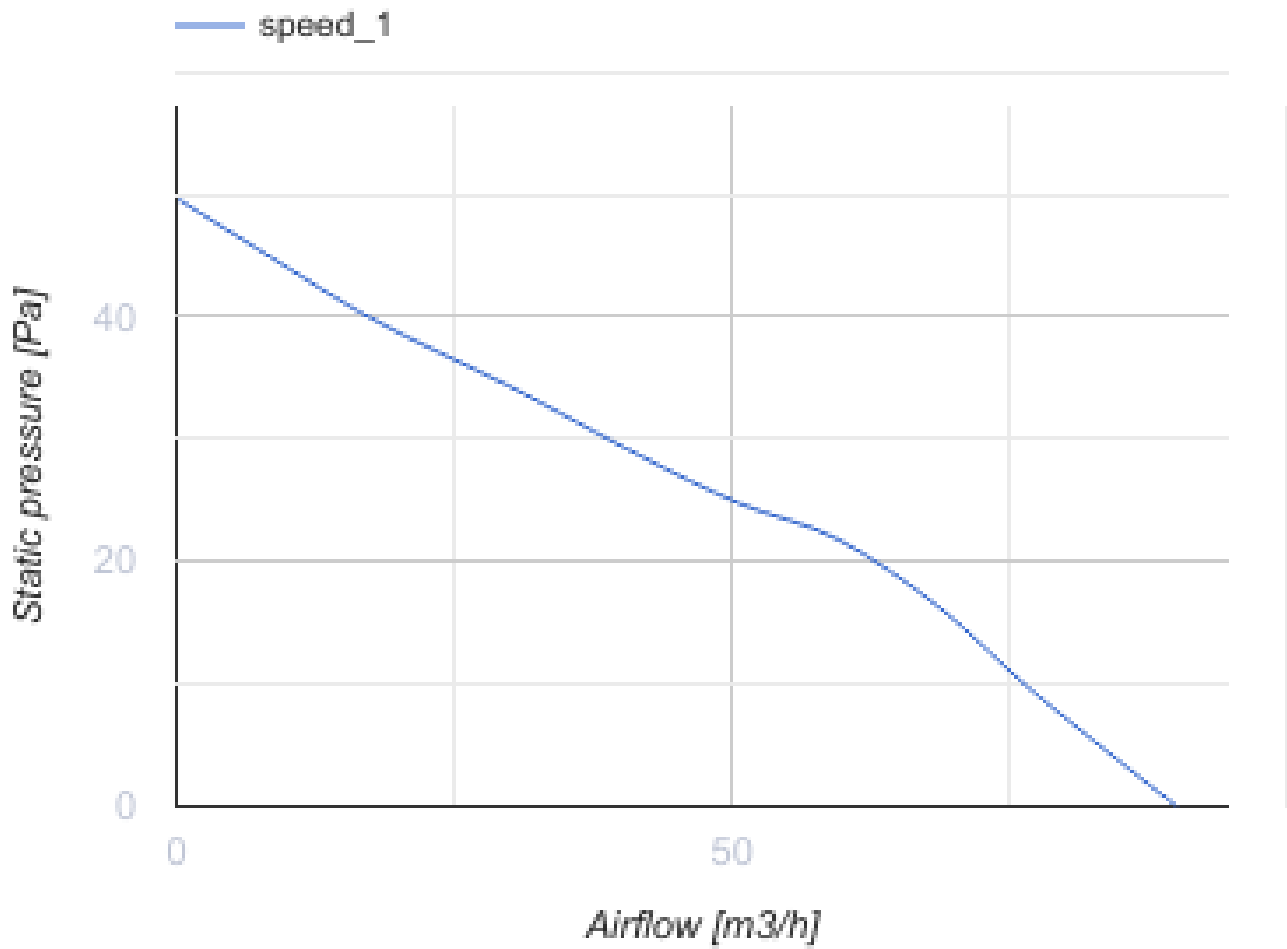

### Dimensions

D	B	L	L1
99	168	110	29



## Accessories

### Flanges

Name	Photo	Description
<a href="#">FO 100</a>		The window flange applicable for all VENTS fans except for VKO, VKO1, iFan, Quiet, MAO, CF

## Ecodesign

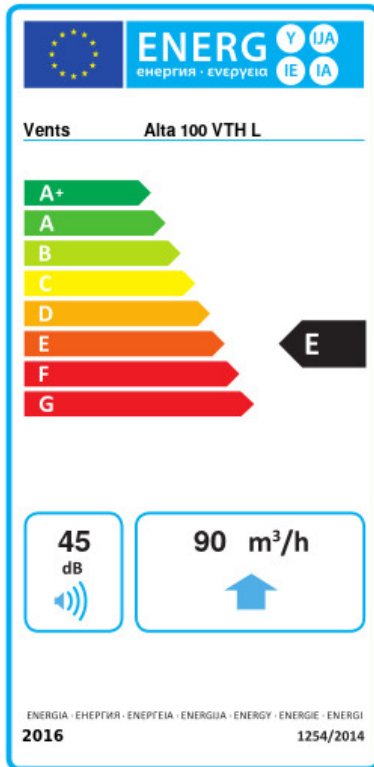

Trademark	Vents					
Model	Alta 100 VTH L					
Specific energy consumption (SEC) (kWh/(m <sup>2</sup> /a))	Cold		Average		Warm	
	-30.1	B	-13.7	E	-4.3	F
Type of ventilation unit	Unidirectional					
Type of drive installed	Single speed					
Type of heat recovery system	None					
Maximum flow rate (m <sup>3</sup> /h)	90					
Electric power input (W)	10					
Reference flow rate (m <sup>3</sup> /s)	0.018					
Specific power input (SPI) (W/(m <sup>3</sup> /h))	0.111					
Control typology	Manual control					
Maximum external leakage rates (%)	2.7					
Declared typology	RVU UVU					
Sound power level (dB(A))	45					
The annual electricity consumption (AEC) (kWh/a)	Cold		Average		Warm	
	139		139		139	
The annual heating saved (AHS) (kWh/a)	Cold		Average		Warm	
	3355		1715		776	