

# AOW1 30



Air unit with the water heat exchanger for arrangement of cost-saving and efficient air heating in various premises

- Maximum airflow: 3000
- Sound pressure level LpA at 3 m: 55
- Motor type: AC
- Casing material: Coated steel

	Unit of measurement	AOW1 30
Phases	-	1
Minimum supply voltage	V	230
Maximum supply voltage	V	230
Power supply frequency	Hz	50
Rated power	W	191
Unit current	A	0.85
Maximum airflow	m <sup>3</sup> /h	3000
Sound pressure level LpA at 3 m	dB(A)	55
Weight	kg	31
Ingress protection rating	-	IP44

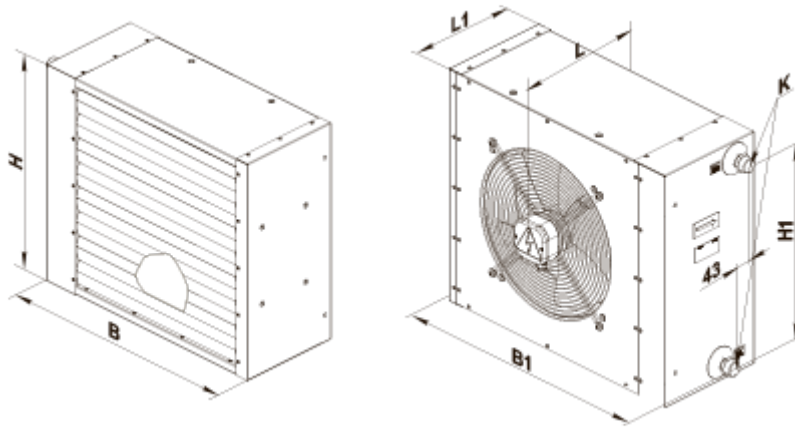

## Dimensions

B	B1	H	H1	L	L1	K
630	690	605	518	355	262	G 3/4"







## Accessories

### Other accessories

Name	Photo	Description
UWT-1E		Control unit
MKP-AOW		Mounting angles
MK-AOW 25		Mounting brackets

### Temperature regulators

Name	Photo	Description
<a href="#">TST-1-300</a>		Temperature regulator
<a href="#">TSTD-1-300</a>		Temperature regulator
<a href="#">RTS-1-400</a>		Temperature regulator
<a href="#">RTSD-1-400</a>		Temperature regulator