

Boost 315 EC S



Inline fans in a polymer casing

- Maximum airflow: 3250
- Sound pressure level LpA at 3 m: 55
- Motor type: EC
- Impeller type: Mixed-flow
- Casing material: Plastic
- Installation in any position

	Unit of measurement	Boost 315 EC S
Connected air duct size	mm	315
Speed	-	1
Minimum supply voltage	V	230
Maximum supply voltage	V	230
Power supply frequency	Hz	50/60
Rated power	W	353
Unit current	A	1.56
Maximum airflow	m ³ /h	3250
Sound pressure level LpA at 3 m	dB(A)	55
Transported air temperature (max)	°C	55
Transported air temperature (min)	°C	-25
Ingress protection rating	-	IPX4
Ingress protection rating of the drive	-	IP44

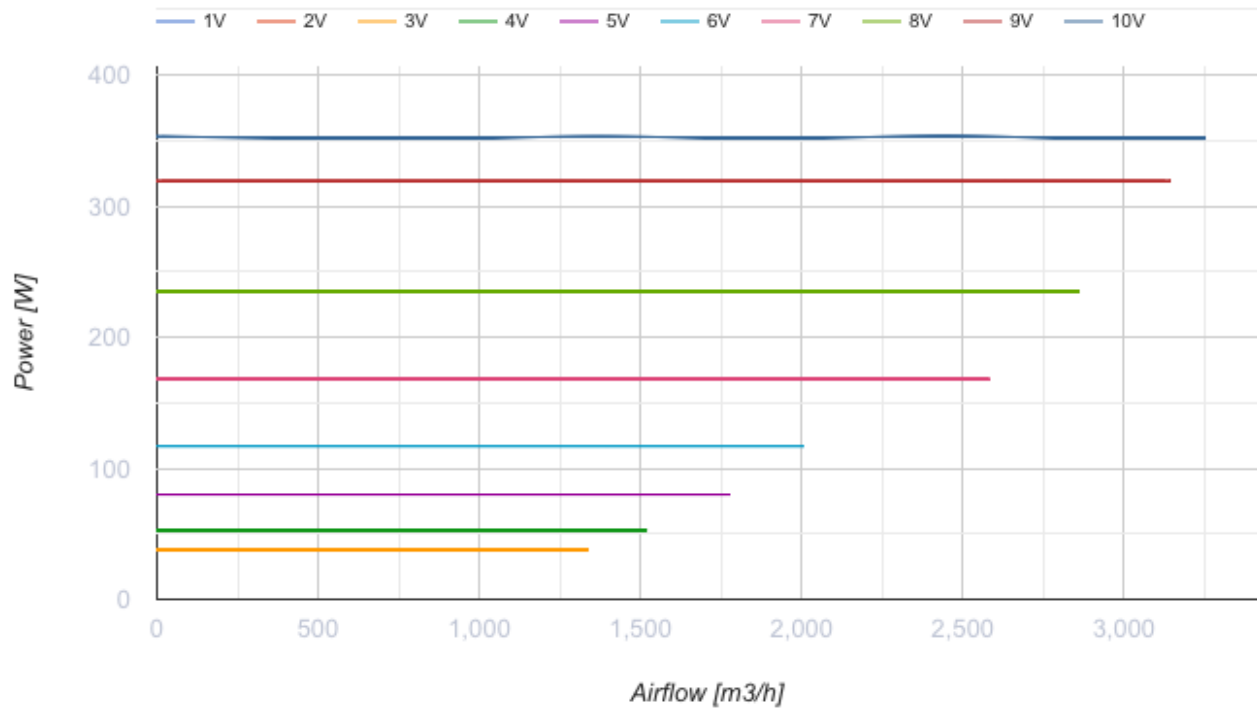
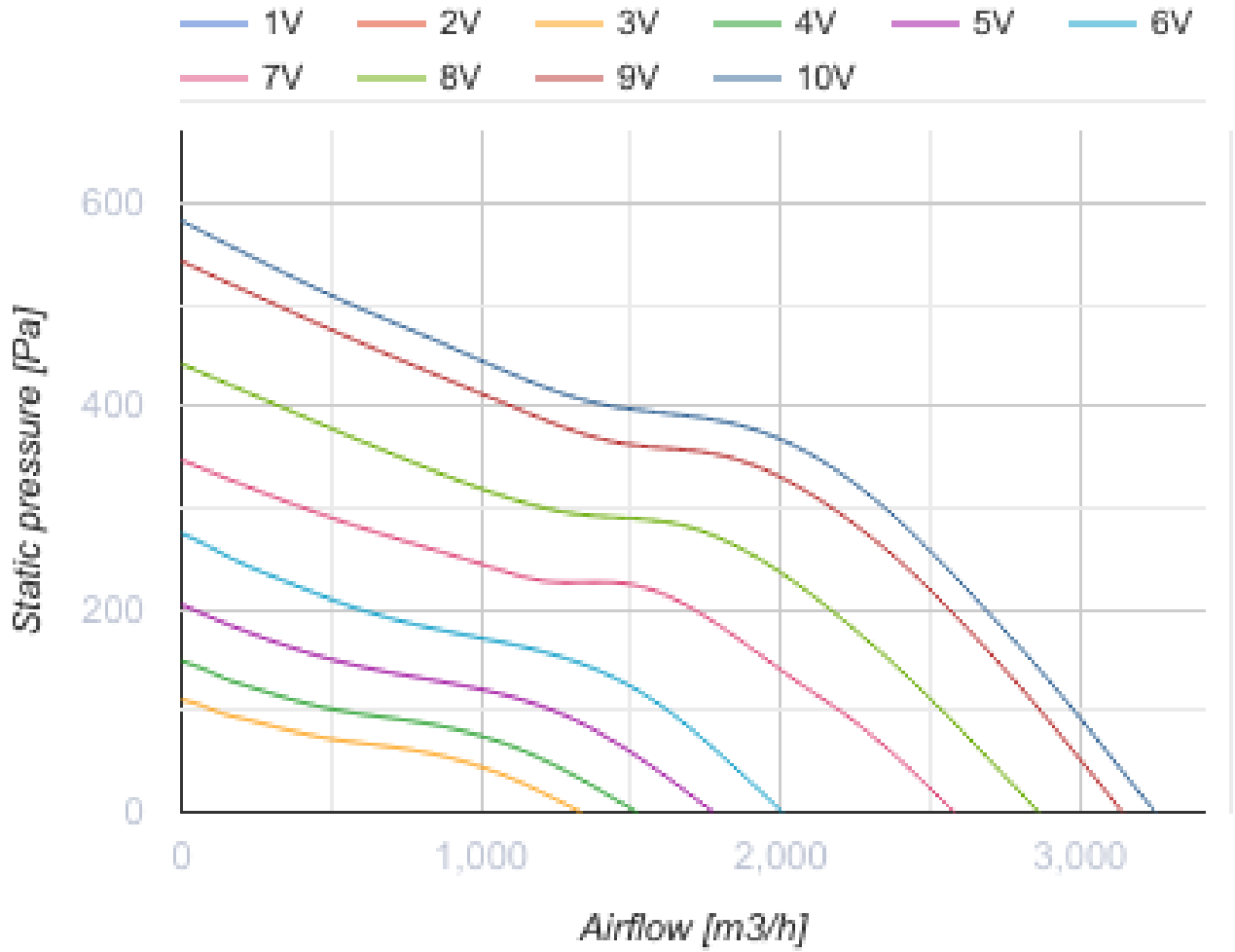

Dimensions

$\varnothing D$	$\varnothing D1$	A	H
313	390	388	450

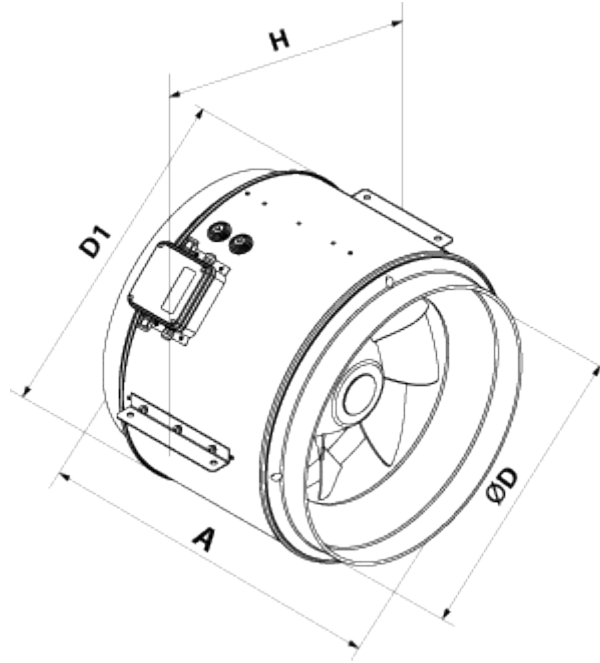

Ecodesign

Trademark	Vents
Model	Boost 315 EC S
Type of drive installed	Integrated VSD
Type of heat recovery system	None
Nominal flow rate (m ³ /s)	0.522
Nominal external pressure (Pa)	380
Maximum external leakage rates (%)	2.7
Static efficiency (%)	57.5
Declared typology	NRVU UVU
Effective electric power input (kW)	0.352
Sound power level (dB(A))	75