

# Boost 400 EC



Mixed-flow inline fans with EC-motors

- Maximum airflow: 5700
- Sound pressure level LpA at 3 m: 60
- Motor type: EC
- Impeller type: Mixed-flow
- Casing material: Plastic
- Installation in any position

	Unit of measurement	Boost 400 EC
Connected air duct size	mm	400
Speed	-	1
Minimum supply voltage	V	230
Maximum supply voltage	V	230
Power supply frequency	Hz	50/60
Rated power	W	726
Unit current	A	4.8
Maximum airflow	m <sup>3</sup> /h	5700
Sound pressure level LpA at 3 m	dB(A)	60
Transported air temperature (max)	°C	55
Transported air temperature (min)	°C	-25
Ingress protection rating	-	IPX4
Ingress protection rating of the drive	-	IP44

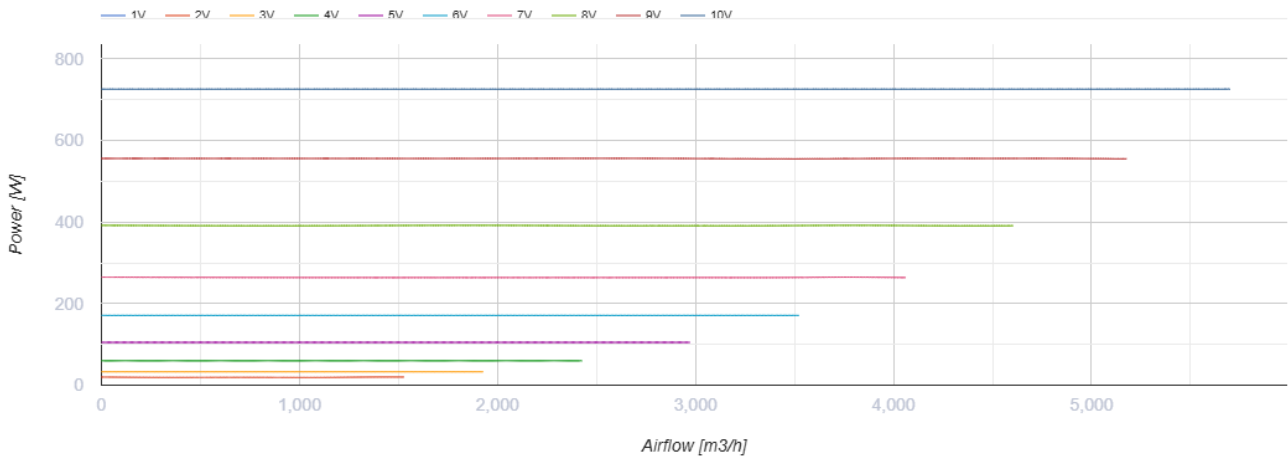
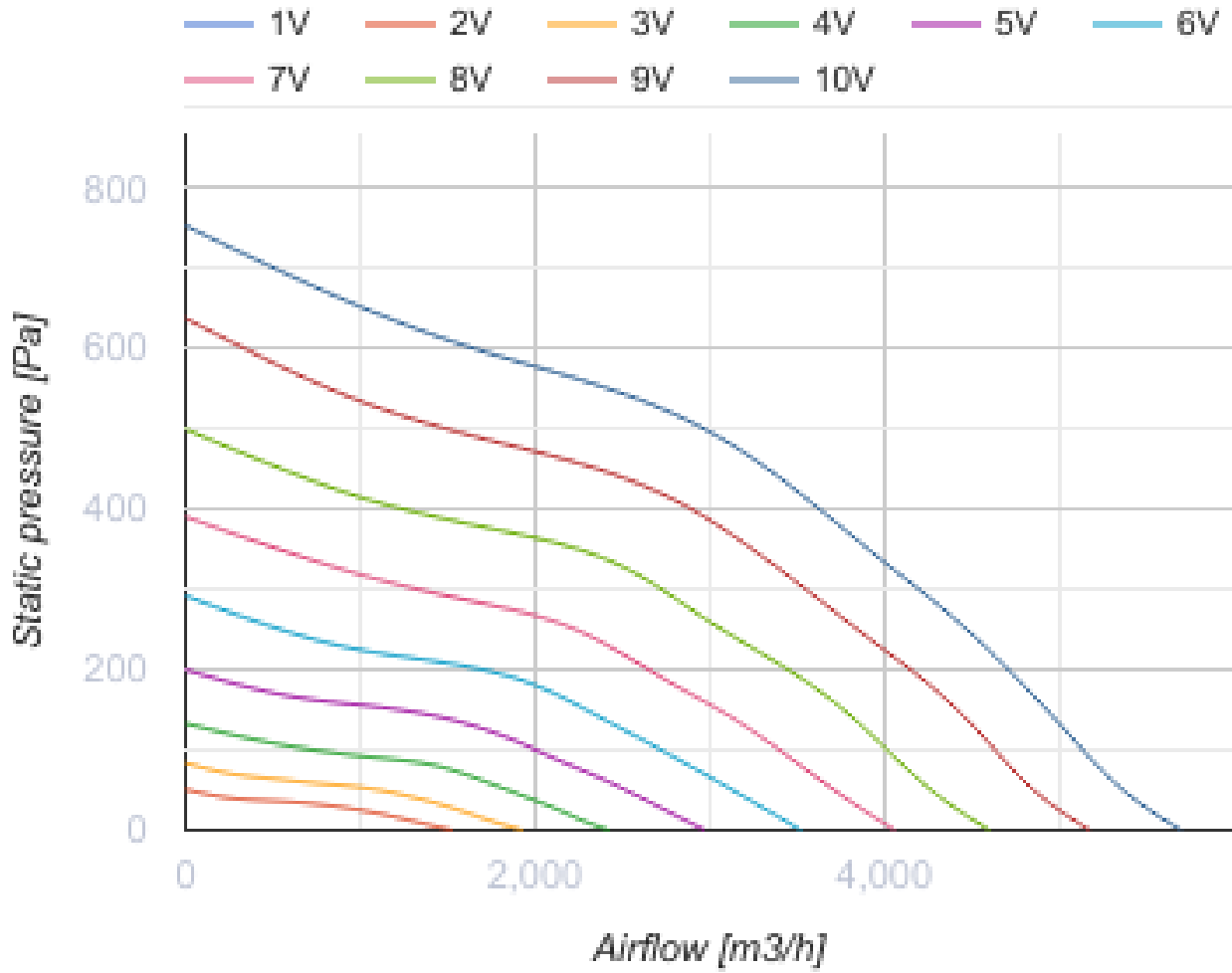

## Dimensions

ØD	ØD1	A	H
395	441	388	500

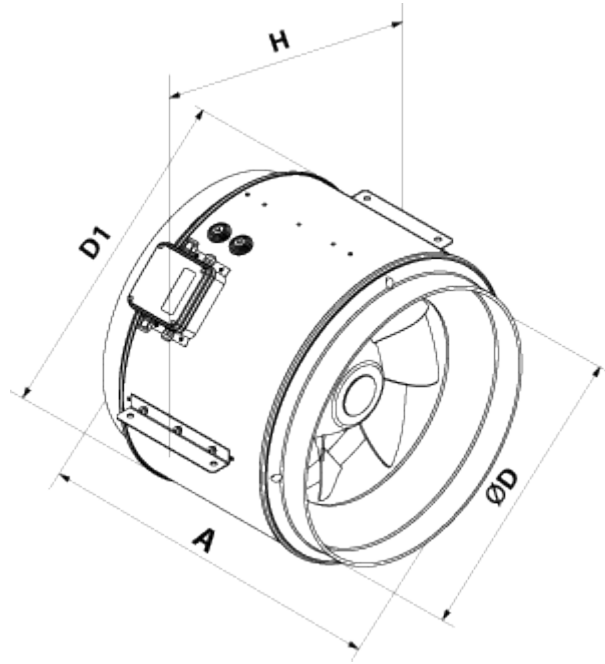

## Ecodesign

Trademark	Vents
Model	Boost 400 EC
Type of drive installed	Integrated VSD
Type of heat recovery system	None
Nominal flow rate (m <sup>3</sup> /s)	1.161
Nominal external pressure (Pa)	300
Maximum external leakage rates (%)	2.7
Static efficiency (%)	53.7
Declared typology	NRVU UVU
Sound power level (dB(A))	80
Effective electric power input (kW)	0.726