

Boost-I 355 Un



Mixed-flow inline fans in sound-insulated casings

- Maximum airflow: 2360
- Sound pressure level LpA at 3 m: 1470
- Sound insulation
- Motor type: AC
- Control: Speed controller
- Impeller type: Mixed-flow
- Casing material: Galvanized steel
- Installation in any position
- Cable with mains plug
- Temperature sensor: Remote

	Unit of measurement	Boost-I 355 Un		
Connected air duct size	mm	355		
Speed	-	3		
Phases	-	1		
Minimum supply voltage	V	230		
Maximum supply voltage	V	230		
Power supply frequency	Hz	50		
Rated power	W	126	131	150
Unit current	A	0.60	0.58	0.66
Maximum airflow	m ³ /h	1986	2170	2360
rotation speed at 50hz	-	1350	1400	1470
Sound pressure level LpA at 3 m	dB(A)	1350	1400	1470
Weight	kg	20.7		
Transported air temperature (max)	°C	55		
Transported air temperature (min)	°C	-25		
Ambient air temperature min	°C	1		
Ambient air temperature max	°C	40		
Ingress protection rating	-	IPX4		
Ingress protection rating of the drive	-	IP20		

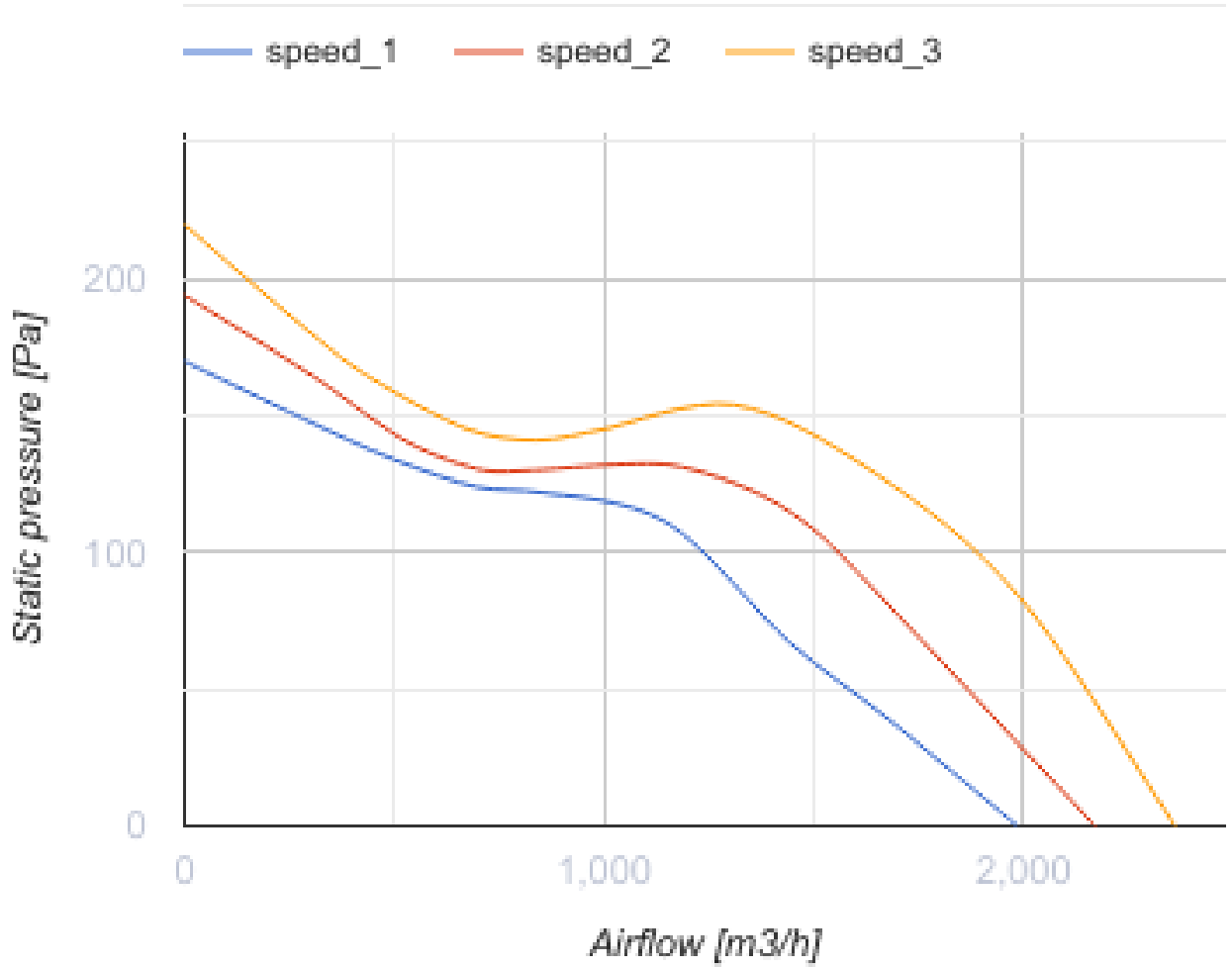

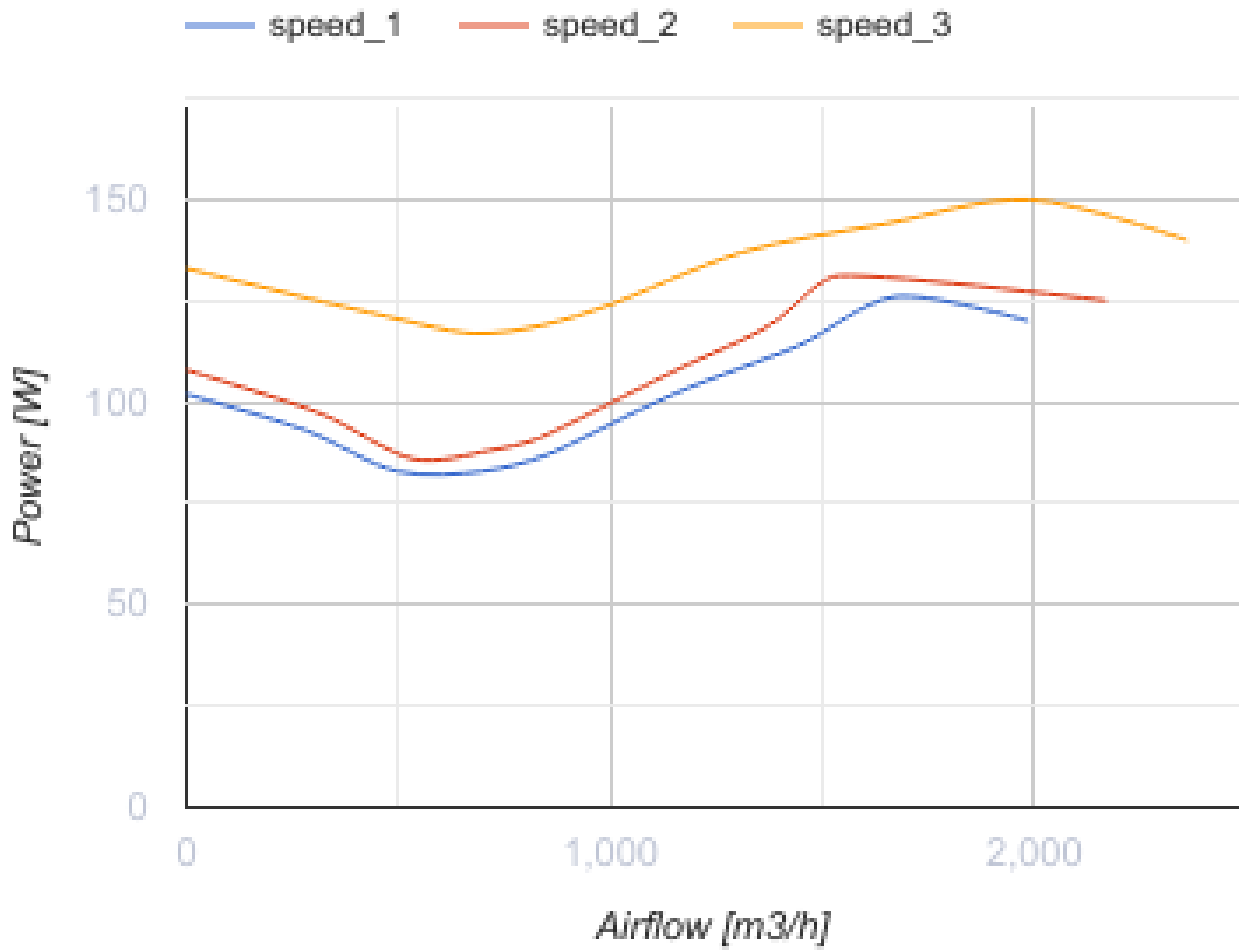



Dimensions

$\varnothing D$	$\varnothing D1$	B	L	L1
354	412	471	601	739



Accessories

For round ducts

Name	Photo	Description
SR 355/600		Silencer is applied for noise absorption produced during the ventilating equipment operation and spread along the ducting systems
SR 355/900		Silencer is applied for noise absorption produced during the ventilating equipment operation and spread along the ducting systems
SR 355/1200		Silencer is applied for noise absorption produced during the ventilating equipment operation and spread along the ducting systems



For round ducts

Name	Photo	Description
KR 355		Air damper for air flow control in round air ducts

Speed control switches

Name	Photo	Description
P3-1-300		Switch

Speed controllers

Name	Photo	Description
RS-1,5-PS		Used in ventilation systems for switching on/off and speed control of single-phase fan motors with voltage control
RS-1-400		Speed controller
RS-3,0-T		Applied in ventilation systems for speed switching ON/OFF and speed control of single-phase power-controlled motors