

# Boost-I 400 T



Mixed-flow inline fans in sound-insulated casings

- Maximum airflow: 3185
- Sound pressure level LpA at 3 m: 37
- Sound insulation
- Motor type: AC
- Impeller type: Mixed-flow
- Casing material: Galvanized steel
- Installation in any position
- Timer: Turn off timer

	Unit of measurement	Boost-I 400 T		
Connected air duct size	mm	400		
Speed	-	3		
Phases	-	1		
Minimum supply voltage	V	230		
Maximum supply voltage	V	230		
Power supply frequency	Hz	50		
Rated power	W	197	204	224
Unit current	A	0.91	0.90	0.98
Maximum airflow	m <sup>3</sup> /h	2543	2979	3185
rotation speed at 50hz	-	1320	1390	1446
Sound pressure level LpA at 3 m	dB(A)	34	35	37
Weight	kg	22.8		
Transported air temperature (max)	°C	55		
Transported air temperature (min)	°C	-25		
Ambient air temperature min	°C	1		
Ambient air temperature max	°C	40		
Ingress protection rating	-	IPX4		
Ingress protection rating of the drive	-	IP20		

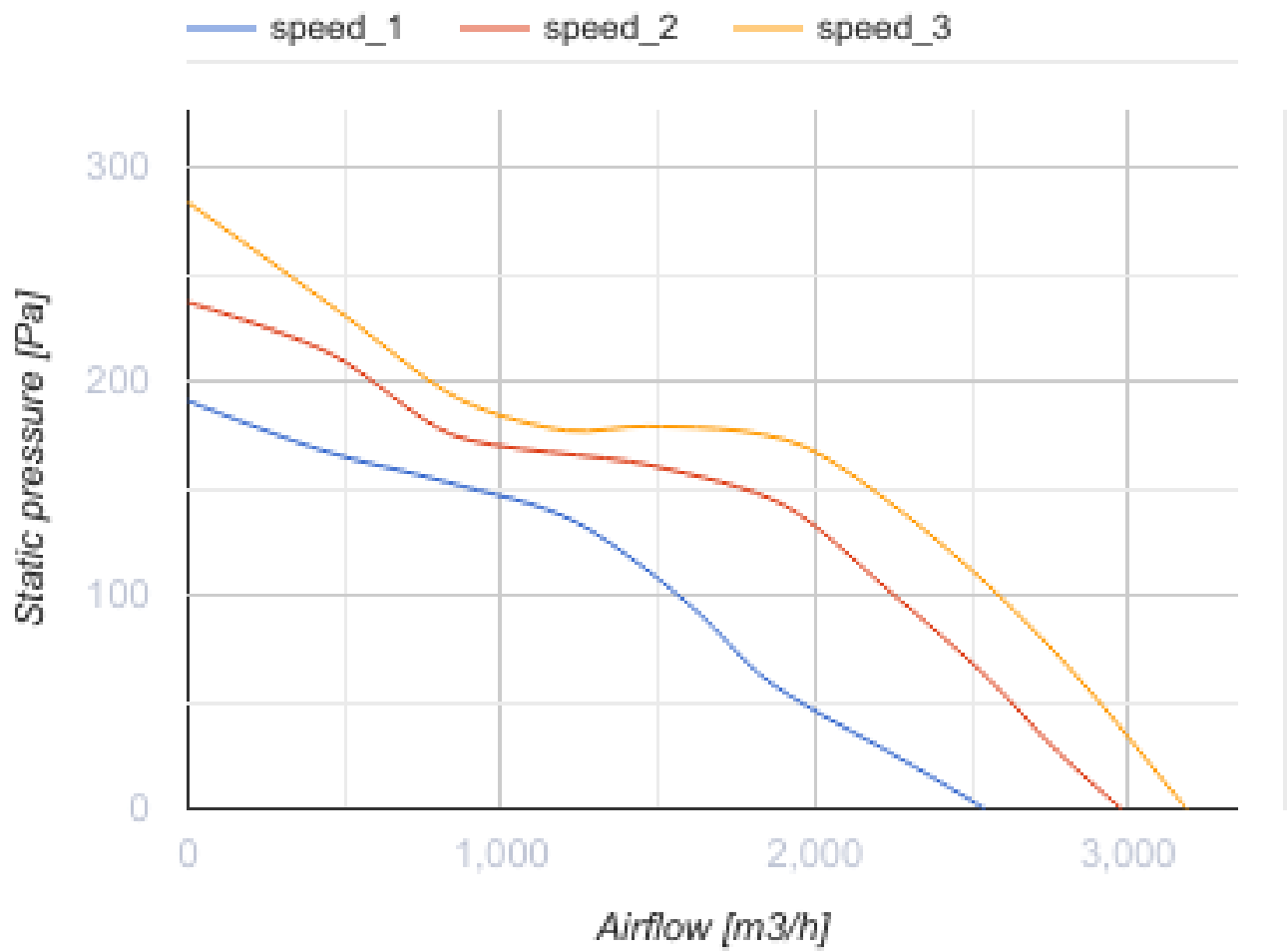



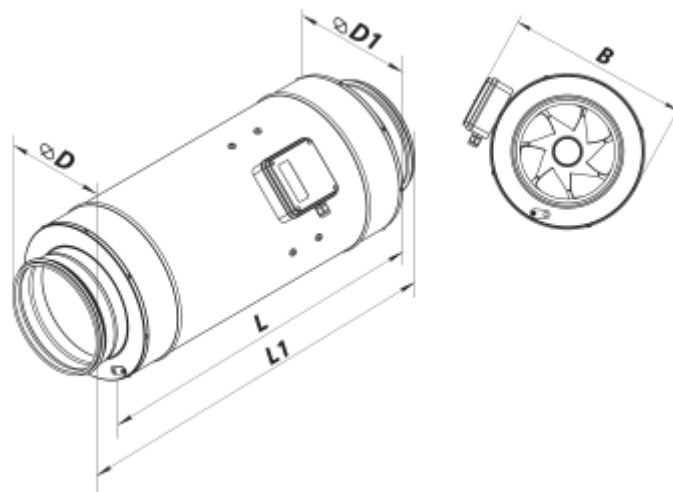

**Dimensions**

Ø D	Ø D1	B	L	L1
399	460	517	648	785



## Accessories

### For round ducts

Name	Photo	Description
<a href="#">SR 400/900</a>		Silencers made of galvanized steel filled with non-combustible sound-absorbing material
<a href="#">SR 400/1200</a>		Silencers made of galvanized steel filled with non-combustible sound-absorbing material



### For round ducts

Name	Photo	Description
<a href="#">KR 400</a>		Air dampers for controlling air flow in round air ducts

### Speed control switches

Name	Photo	Description
<a href="#">P3-1-300</a>		Switch

### Speed controllers

Name	Photo	Description
<a href="#">RS-1.5-PS</a>		Used in ventilation systems for switching on/off and speed control of single-phase fan motors with voltage control
<a href="#">RS-1-400</a>		Speed controller
<a href="#">RS-3.0-T</a>		Applied in ventilation systems for speed switching ON/OFF and speed control of single-phase power-controlled motors