

HBF 250 Round TH



Vents HBF is a series of designer ceiling-mounted centrifugal extract fans

- Maximum airflow: 482
- Sound pressure level LpA at 3 m: 36
- Backdraft protection: Backdraft damper
- Humidity sensor
- Timer: Turn off timer

	Unit of measurement	HBF 250 Round TH
Speed	-	1
Minimum supply voltage	V	220
Maximum supply voltage	V	240
Power supply frequency	Hz	50
Rated power	W	57
Unit current	A	0.25
Maximum airflow	m ³ /h	482
rotation speed at 50hz	-	1085
Sound pressure level LpA at 3 m	dB(A)	36
Ingress protection rating	-	IPX4

Dimensions

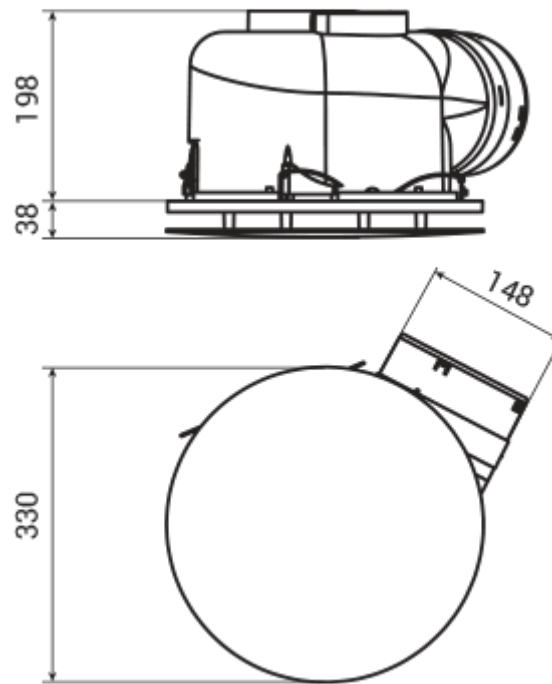

Accessories

Speed controllers

Name	Photo	Description
RS-1-0,5		Used in ventilation systems for switching on/off and speed control of single-phase fan motors with voltage control

Other accessories

Name	Photo	Description
MV 152 V ASA		Supply and exhaust hoods

Plastic

Name	Photo	Description
MV 150 V		Supply and exhaust plastic grilles