

KSB 100 K2



Inline centrifugal fans in heat- and sound-insulated casing

- Maximum airflow: 285
- Sound pressure level LpA at 3 m: 34
- Sound insulation
- Motor type: AC
- Impeller type: Centrifugal backward curved blades
- Casing material: Aluzinc
- Installation in any position

	Unit of measurement	KSB 100 K2
Connected air duct size	mm	100
Speed	-	1
Phases	-	1
Minimum supply voltage	V	230
Maximum supply voltage	V	230
Power supply frequency	Hz	50
Rated power	W	58
Unit current	A	0.25
Maximum airflow	m ³ /h	285
rotation speed at 50hz	-	2530
Sound pressure level LpA at 3 m	dB(A)	34
Weight	kg	13
Transported air temperature (max)	°C	55
Transported air temperature (min)	°C	-25
Ingress protection rating	-	IPX4
Ingress protection rating of the drive	-	IP44

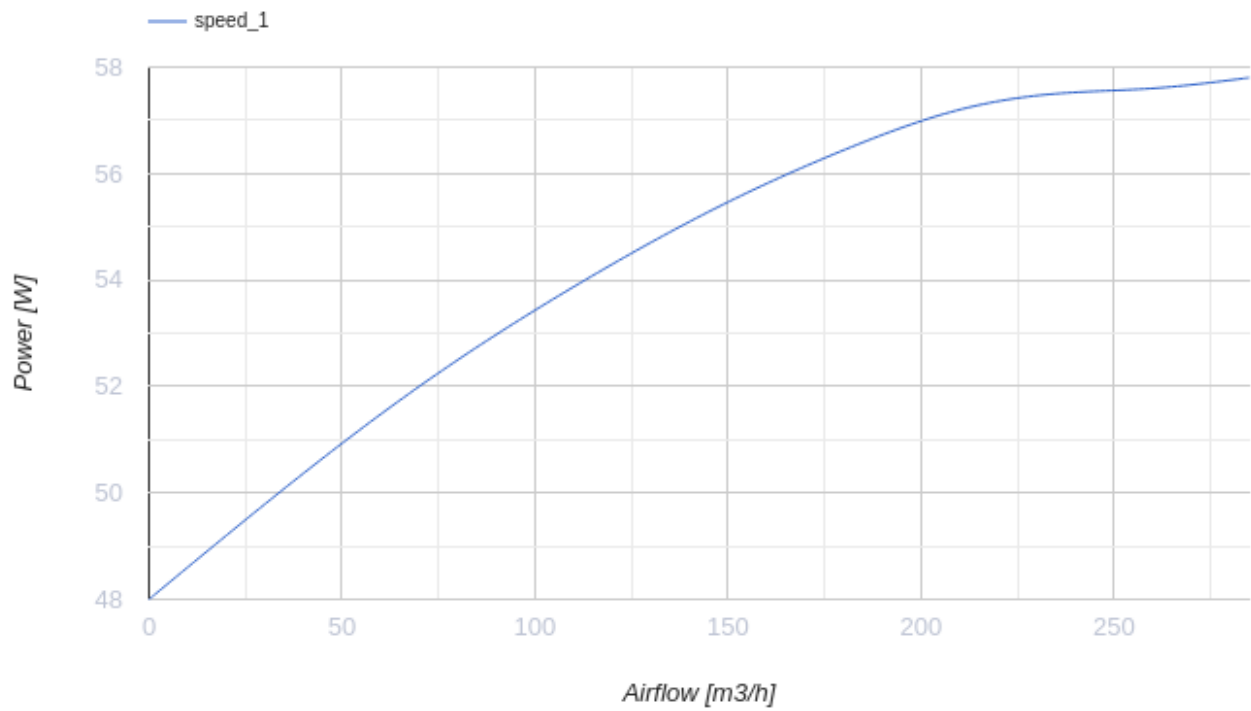
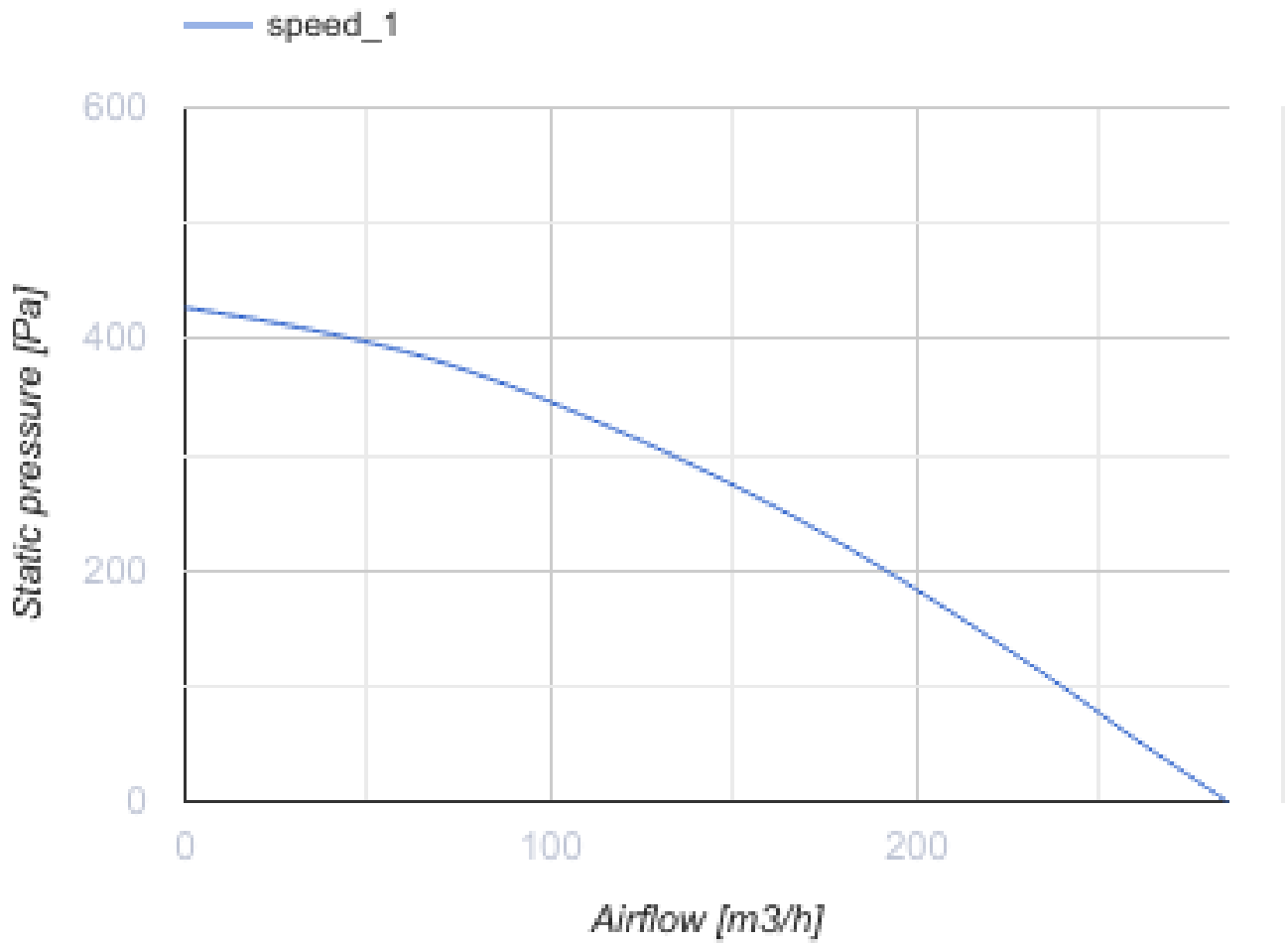

Dimensions

ØD	B	B1	H	L	L1	L2
99	420	228	258	517	507	414

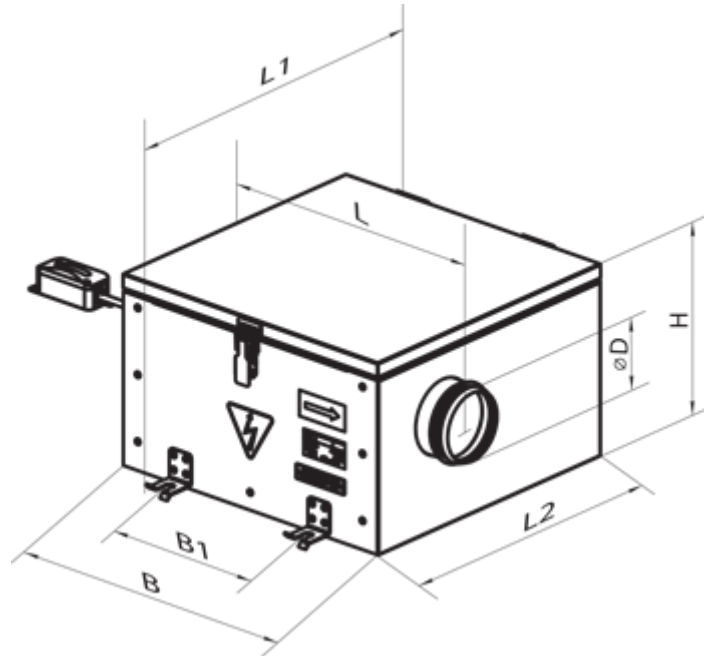

Ecodesign

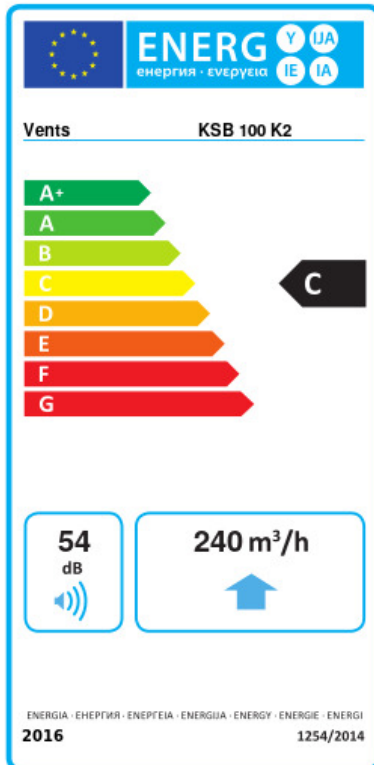

Trademark	Vents					
Model	KSB 100 K2					
Specific energy consumption (SEC) (kWh/(m ² /a))	Cold		Average		Warm	
	51	A+	23.9	C	8.4	F
Type of ventilation unit	Unidirectional					
Type of drive installed	Variable speed					
Type of heat recovery system	None					
Maximum flow rate (m ³ /h)	240					
Electric power input (W)	58					
Reference flow rate (m ³ /s)	0.047					
Reference pressure difference (Pa)	50					
Specific power input (SPI) (W/(m ³ /h))	0.333					
Control typology	Local demand control					
Maximum external leakage rates (%)	2.7					
Declared typology	RVU UVU					
Sound power level (dB(A))	54					
The annual electricity consumption (AEC) (kWh/a)	Cold		Average		Warm	
	176		176		176	
The annual heating saved (AHS) (kWh/a)	Cold		Average		Warm	
	5536		2830		1280	