

# KSD 315-4E



Inline centrifugal fan for round ducts in heat- and soundinsulated casing

- Maximum airflow: 3200
- Sound pressure level LpA at 3 m: 45
- Sound insulation
- Motor type: AC
- Impeller type: Centrifugal forward curved blades
- Casing material: Galvanized steel
- Installation in any position

	Unit of measurement	KSD 315-4E
Connected air duct size	mm	315
Speed	-	1
Minimum supply voltage	V	230
Maximum supply voltage	V	230
Power supply frequency	Hz	50
Rated power	W	723
Unit current	A	3.15
Maximum airflow	m <sup>3</sup> /h	3200
Sound pressure level LpA at 3 m	dB(A)	45
Weight	kg	33
Transported air temperature (max)	°C	50
Transported air temperature (min)	°C	-20
Ingress protection rating	-	IPX4

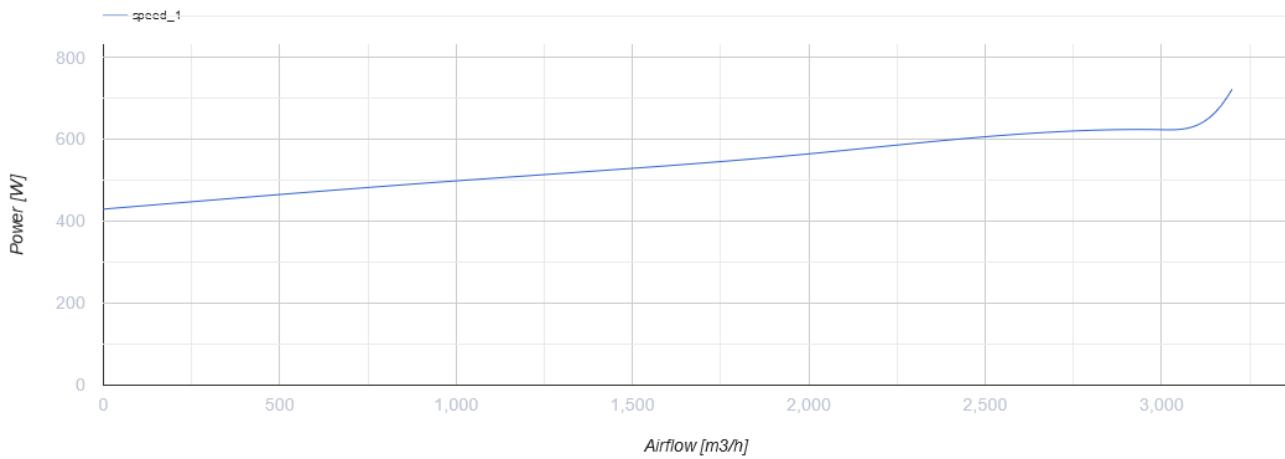
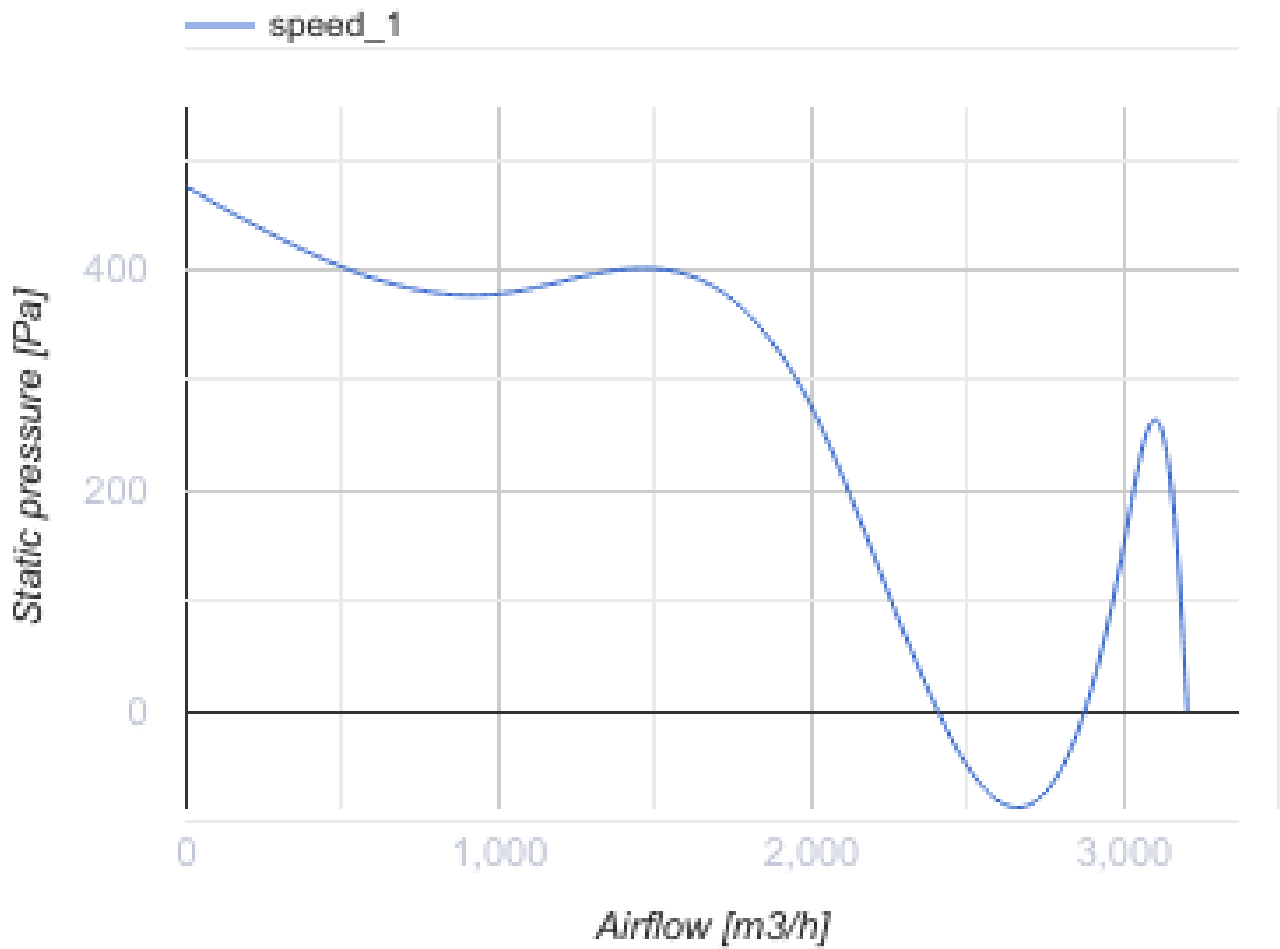

## Dimensions

∅D	∅d	B	B1	H	H1	H2	H4	L	L1	L2
313	20	600	550	500	340	251	537	680	580	510



## Ecodesign

Trademark	Vents
Model	KSD 315-4E
Type of drive installed	External MSD or VSD
Type of heat recovery system	None
Nominal flow rate (m <sup>3</sup> /s)	0.476
Nominal external pressure (Pa)	308
Maximum external leakage rates (%)	2.7
Static efficiency (%)	25.4
Sound power level (dB(A))	65
Effective electric power input (kW)	0.59
Declared typology	NRVU UVU