

KSK 150 4E



Kitchen inline fans in sound-insulated casings with operational temperature of 120 °C

- Maximum airflow: 700
- Sound pressure level LpA at 3 m: 41
- Sound insulation
- Motor type: AC
- Impeller type: Centrifugal forward curved blades
- Casing material: Galvanized steel

	Unit of measurement	KSK 150 4E
Connected air duct size	mm	150
Speed	-	1
Minimum supply voltage	V	230
Maximum supply voltage	V	230
Power supply frequency	Hz	50
Rated power	W	180
Unit current	A	1.7
Maximum airflow	m ³ /h	700
Sound pressure level LpA at 3 m	dB(A)	41
Weight	kg	17
Transported air temperature (max)	°C	120
Transported air temperature (min)	°C	-20
Ingress protection rating	-	IP54

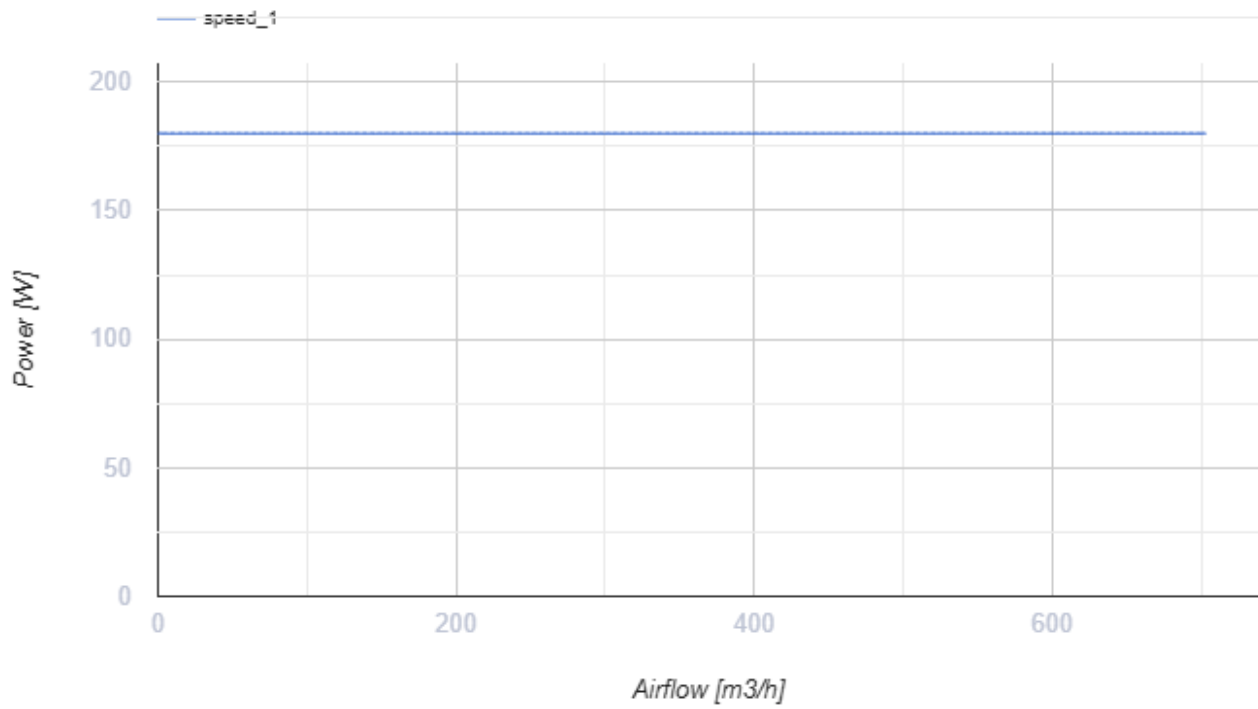
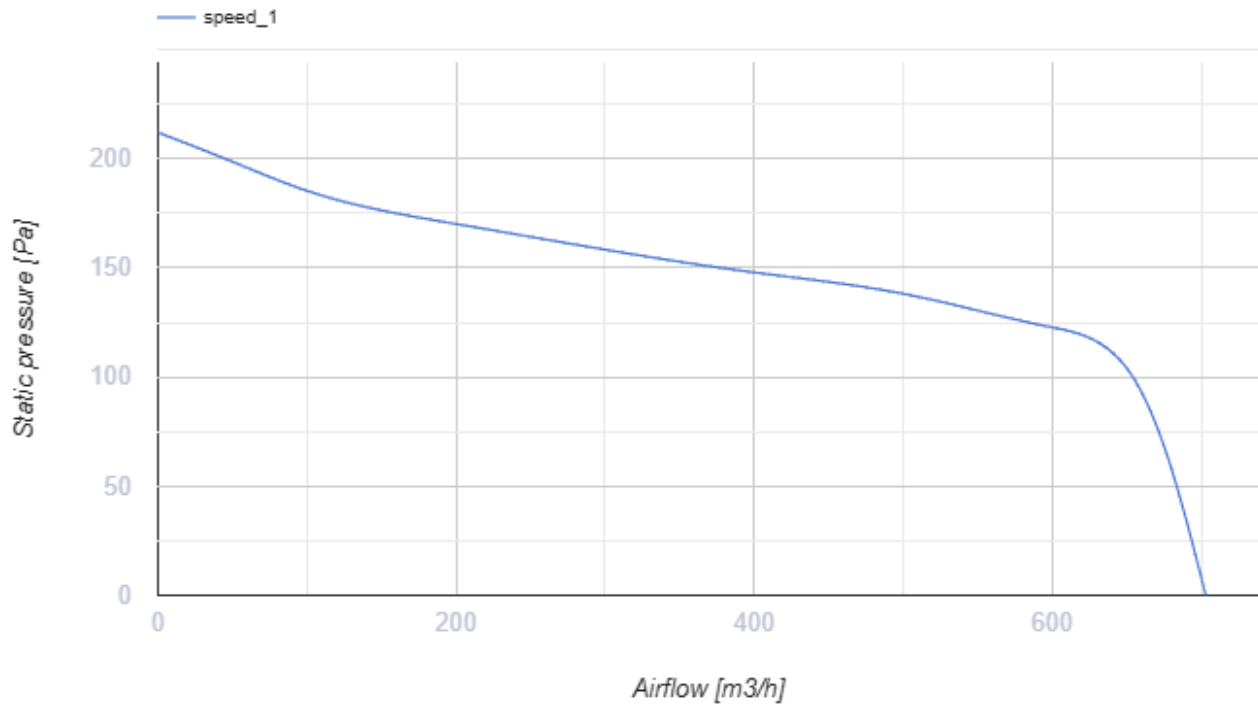

Dimensions

ØD	B	B1	H	H1	L	L1	L2	L3	L4
150	410	330	540	365	525	500	470	475	205



Accessories

For round ducts

Name	Photo	Description
KOM 150		Spring-loaded backdraft damper for round ducts

Other accessories

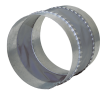
Name	Photo	Description
VVG 150		Flexible anti-vibration connector