

# OV 500 EC



Wall-mounted axial fans with EC-motors

- Maximum airflow: 8500
- Sound pressure level LpA at 3 m: 70
- Motor type: EC
- Impeller type: Axial
- Casing material: Coated steel

	Unit of measurement	OV 500 EC
Phases	-	1
Minimum supply voltage	V	230
Maximum supply voltage	V	230
Power supply frequency	Hz	50/60
Rated power	W	700
Unit current	A	3.1
Maximum airflow	m <sup>3</sup> /h	8500
Sound pressure level LpA at 3 m	dB(A)	70
Weight	kg	8.31
Transported air temperature (max)	°C	60
Transported air temperature (min)	°C	-25
Ingress protection rating	-	IPX5
Ingress protection rating of the drive	-	IP55

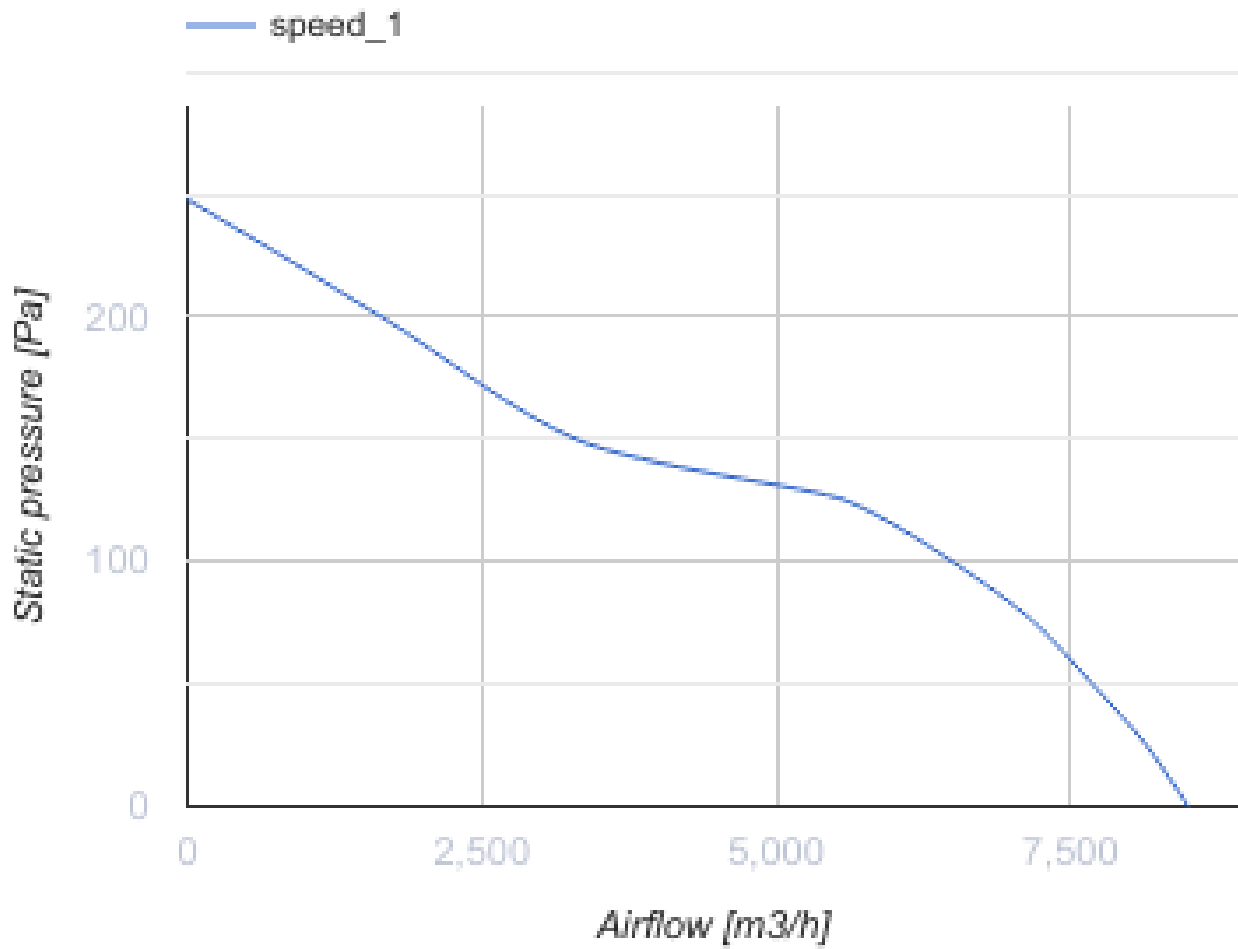

### Dimensions

ØD	ØD1	Ød1	L	L1	W	W1
520	568	11	180	294	655	615

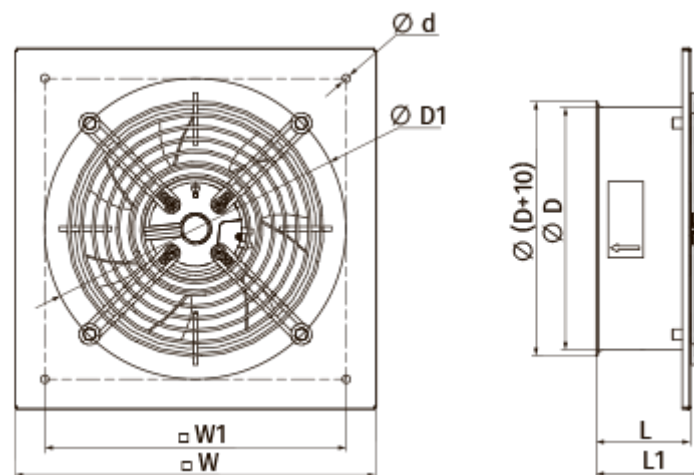

## Accessories

### Speed controllers

Name	Photo	Description
<a href="#">R-1/010</a>		Speed controller for EC motors