

# OVK 2E 250



Low pressure axial fans in the steel casing for wall mounting

- Maximum airflow: 1050
- Sound pressure level LpA at 3 m: 50
- Motor type: AC
- Impeller type: Axial
- Casing material: Polypropylene/Thermoplastic elastomer
- Installation in any position

	Unit of measurement	OVK 2E 250
Connected air duct size	mm	250
Speed	-	1
Minimum supply voltage	V	220
Maximum supply voltage	V	240
Power supply frequency	Hz	50/60
Rated power	W	80
Unit current	A	0.4
Maximum airflow	m <sup>3</sup> /h	1050
Sound pressure level LpA at 3 m	dB(A)	50
Weight	kg	3.8
Transported air temperature (max)	°C	60
Transported air temperature (min)	°C	-30
Ingress protection rating	-	IP24

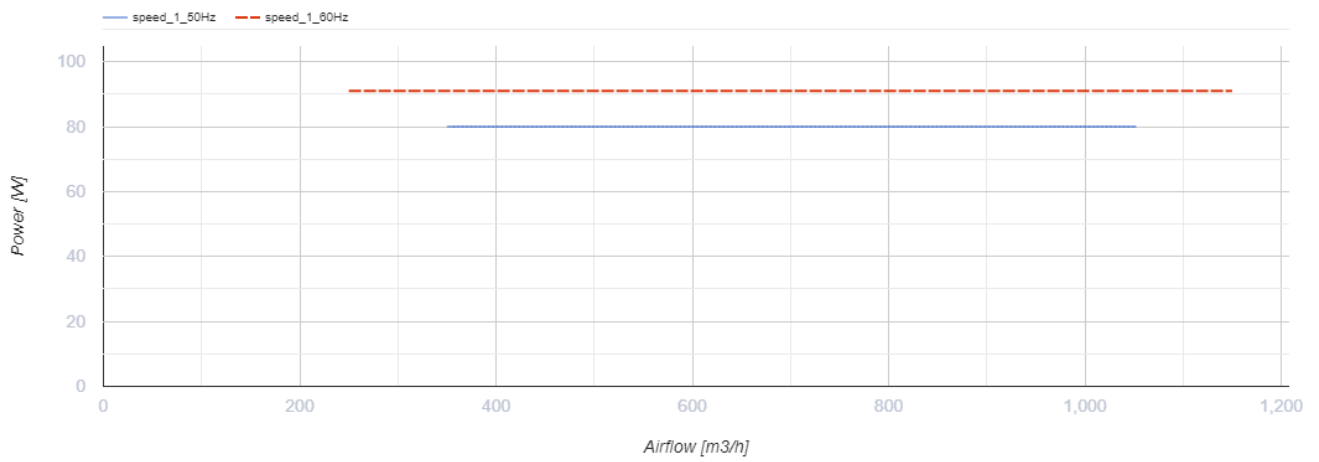
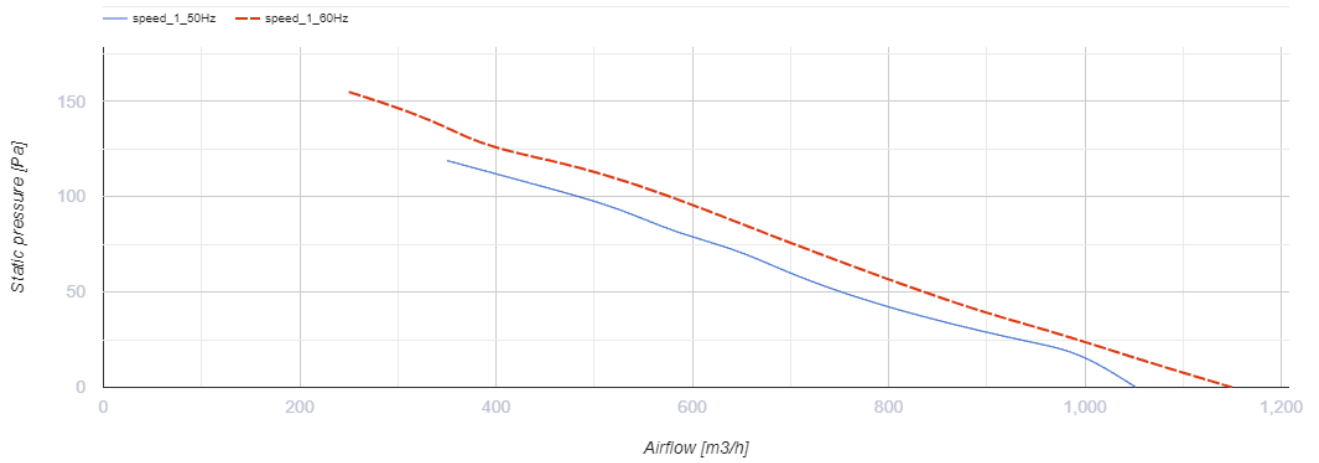

## Dimensions

ØD	ØD1	ØD2	Ød	L
260	318	340	7	135



## Ecodesign

Trademark	Vents
Model	OVK 2E 250
Type of drive installed	External MSD or VSD
Type of heat recovery system	None
Nominal flow rate (m <sup>3</sup> /s)	0.146
Nominal external pressure (Pa)	92
Maximum external leakage rates (%)	2.7
Static efficiency (%)	16.8
Declared typology	NRVU UVU
Effective electric power input (kW)	0.082
Sound power level (dB(A))	80