

OVK1 150



Inline axial fans aluminium impellers

- Maximum airflow: 200
- Sound pressure level LpA at 3 m: 33
- Motor type: AC
- Impeller type: Axial
- Casing material: Polypropylene/Thermoplastic elastomer
- Installation in any position

	Unit of measurement	OVK1 150
Connected air duct size	mm	150
Speed	-	1
Minimum supply voltage	V	220
Maximum supply voltage	V	240
Power supply frequency	Hz	50/60
Rated power	W	36
Unit current	A	0.26
Maximum airflow	m ³ /h	200
Sound pressure level LpA at 3 m	dB(A)	33
Weight	kg	2.5
Transported air temperature (max)	°C	40
Transported air temperature (min)	°C	-30
Ingress protection rating	-	IP24
Ingress protection rating of the drive	-	IP44

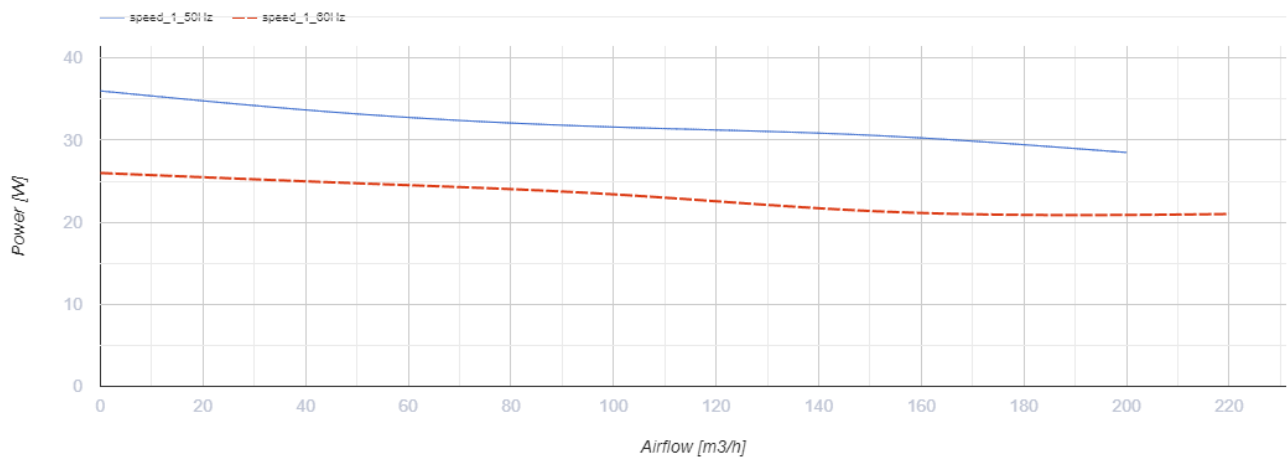
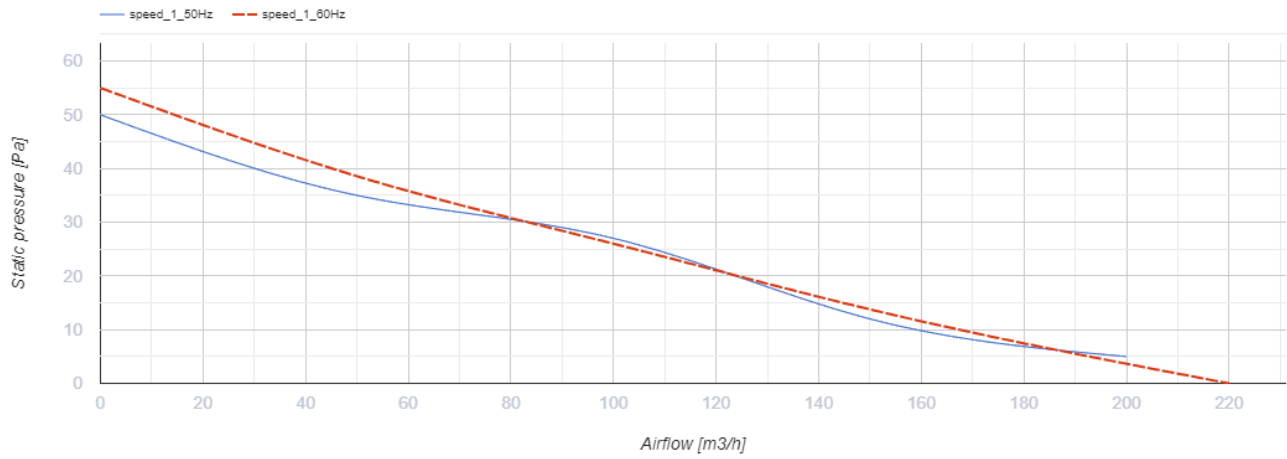

Dimensions

ØD	ØD1	ØD2	Ød	L
162	190	220	7	120



Ecodesign

Trademark	Vents
Model	OVK1 150
Type of drive installed	External MSD or VSD
Type of heat recovery system	None
Nominal flow rate (m ³ /s)	0.027
Nominal external pressure (Pa)	27
Maximum external leakage rates (%)	2.7
Static efficiency (%)	2.8
Declared typology	NRVU UVU
Effective electric power input (kW)	0.027
Sound power level (dB(A))	53